

application guide

PRODUCT MAPS	14
UNDERSTANDING PORTRAIT	45
PORTRAIT – FASCIAS	53
PORTRAIT – DOOR PACKAGES	71
PORTRAIT – FRAME KITS & COMPONENTS	89
PORTRAIT – TEK PIER	117
PORTRAIT – CLERESTORY - OPTOS PROFILE	137
PORTRAIT – LIGHTING, ELECTRICS & COMMUNICATIONS	145
PORTRAIT – MOUNTED STORAGE & ACCESSORIES	171
PORTRAIT – INTEGRATION	177
UNDERSTANDING LANDSCAPE	187
LANDSCAPE – FASCIAS	197
LANDSCAPE – DOOR PACKAGES	223
LANDSCAPE – FRAME KITS & COMPONENTS	237
LANDSCAPE – LIGHTING, ELECTRICS & COMMUNICATIONS	271
LANDSCAPE – COLLECTION & ACCESSORIES	299

fascias

F P B Base Fascia

Xpress

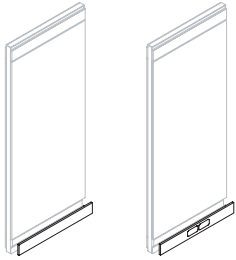

F P C Ceiling Fascia

Xpress



F P M 1 Solid Fascia – Monolithic

Xpress

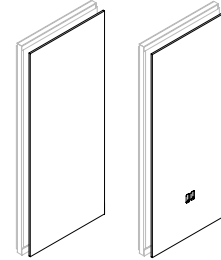

F P F 1 Solid Fascia – Full

Xpress

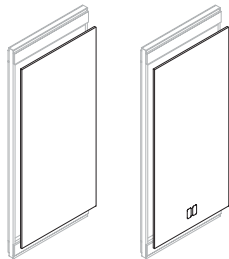

F P S 1 Solid Fascia– Segmented (Level I)

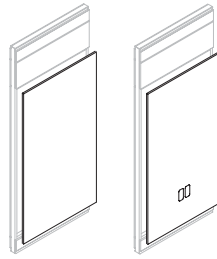

F P S 2 Solid Fascia – Segmented (Level II)



F P S M 1 Solid Fascia – Segmented Monolithic (Level I)

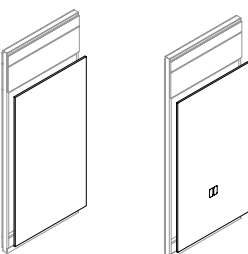

F P S M 2 Solid Fascia – Segmented Monolithic (Level II)

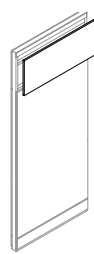

F P W 1 Solid Fascia – Working Wall (Level I)

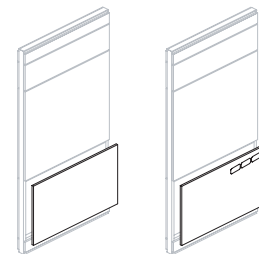

F P W 2 Solid Fascia – Working Wall (Level II)

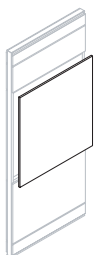

F P W 3 Solid Fascia – Working Wall (Level III)

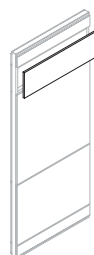

F P W M 1 Solid Fascia – Working Wall Monolithic (Level I)

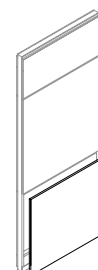

Portrait

fascias (continued)

FPWM3 Solid Fascia – Working Wall Monolithic (Level III)

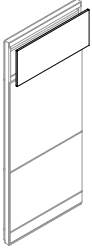

FPGCR Glass Fascia – Single Centered, Round Corner

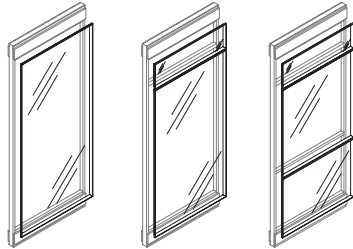

Full Wall Segmented Wall Working Wall

FPGCS Glass Fascia – Single Centered, Square Corner

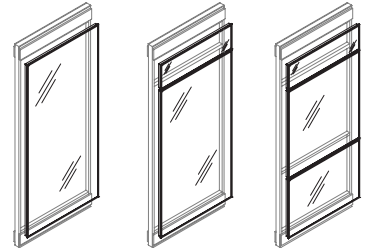

Full Wall Segmented Wall Working Wall

FPGDR Glass Fascia – Double, Round Corner

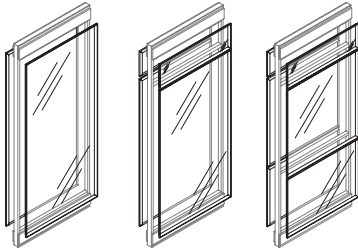

Full Wall Segmented Wall Working Wall

FPGDS Glass Fascia – Double, Square Corner

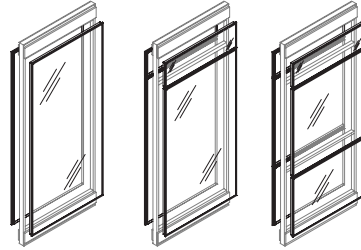

Full Wall Segmented Wall Working Wall

FPAM1 Acoustic Fascia – Monolithic

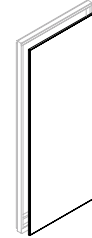

FPAF1 Acoustic Fascia – Full



FPAS1 Acoustic Fascia – Segmented (Level I)

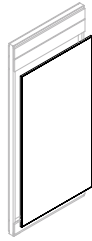

FPAS2 Acoustic Fascia – Segmented (Level II)

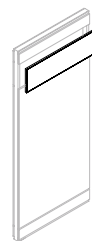

FPASM1 Acoustic Fascia – Segmented Monolithic (Level I)

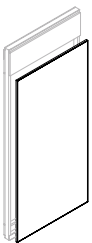

FPASM2 Acoustic Fascia – Segmented Monolithic (Level II)

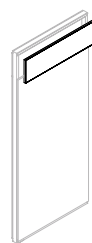

FPAW1 Acoustic Fascia – Working Wall (Level I)

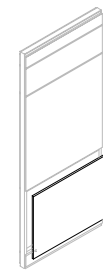

Portrait

fascias (continued)

Portrait	<p>F P A W 2 Acoustic Fascia – Working Wall (Level II)</p>	<p>F P A W 3 Acoustic Fascia – Working Wall (Level III)</p>	<p>F P A W M 1 Acoustic Fascia – Working Wall Monolithic (Level I)</p>
	<p>F P A W M 3 Acoustic Fascia – Working Wall Monolithic (Level III)</p>	<p>F P A T M 1 Acoustic Tackable Fascia – Monolithic</p>	<p>F P A T F 1 Acoustic Tackable Fascia – Full Height</p>
	<p>F P A T S 1 Acoustic Tackable Fascia – Segmented (Level I)</p>	<p>F P A T S 2 Acoustic Tackable Fascia – Segmented (Level II)</p>	<p>F P A T S M 1 Acoustic Tackable Fascia – Segmented Monolithic (Level I)</p>
	<p>F P A T S M 2 Acoustic Tackable Fascia – Segmented Monolithic (Level II)</p>	<p>F P A T W 1 Acoustic Tackable Fascia – Working Wall (Level I)</p>	<p>F P A T W 2 Acoustic Tackable Fascia – Working Wall (Level II)</p>

fascias (continued)

F P A T W 3 Acoustic Tackable Fascia – Working Wall (Level III)

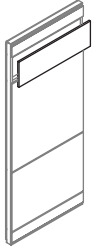

F P A T W M 1 Acoustic Tackable Fascia – Working Wall Monolithic (Level I)

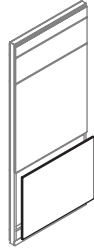

F P A T W M 3 Acoustic Tackable Fascia – Working Wall Monolithic (Level III)

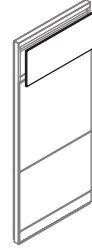

F P M P S 1 Micro Perforated Metal Acoustic Fascia – Segmented (Level I)



F P M P S 2 Micro Perforated Metal Acoustic Fascia – Segmented (Level II)

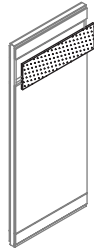

F P M P S M 1 Micro Perforated Metal Acoustic Fascia – Segmented Monolithic (Level I)



F P M P S M 2 Micro Perforated Metal Acoustic Fascia – Segmented Monolithic (Level II)



F P M P W 1 Micro Perforated Metal Acoustic Fascia – Working Wall (Level I)

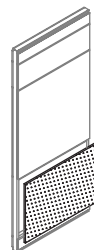

F P M P W 2 Micro Perforated Metal Acoustic Fascia – Working Wall (Level II)

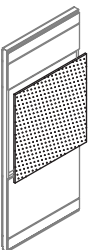

F P M P W 3 Micro Perforated Metal Acoustic Fascia – Working Wall (Level III)

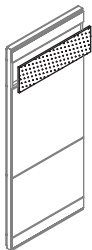

F P M P W M 1 Micro Perforated Metal Acoustic Fascia – Working Wall Monolithic (Level I)



F P M P W M 3 Micro Perforated Metal Acoustic Fascia – Working Wall Monolithic (Level III)

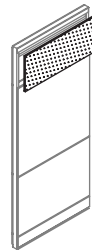

Portrait

fascias (continued)

F P M B S 1 Sheet Metal Backer
– Segmented (Level I)

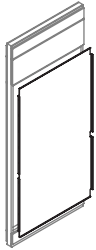

F P M B S 2 Sheet Metal Backer
– Segmented (Level II)

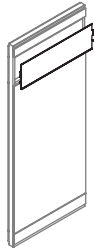

F P M B S M 1 Sheet Metal Backer – Segmented Monolithic (Level I)



F P M B S M 2 Sheet Metal Backer – Segmented Monolithic (Level II)

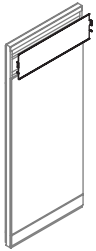

F P M B W 1 Sheet Metal Backer – Working Wall (Level I)

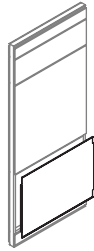

F P M B W 2 Sheet Metal Backer – Working Wall (Level II)

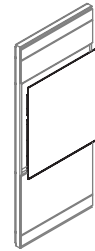

F P M B W 3 Sheet Metal Backer – Working Wall (Level III)

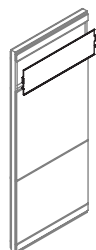

F P M B W M 1 Sheet Metal Backer – Working Wall Monolithic (Level I)

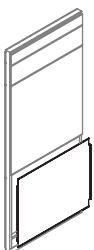

F P M B W M 3 Sheet Metal Backer – Working Wall Monolithic (Level III)

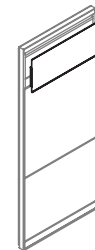

F P R B Fabric Wrapped Base Fascia

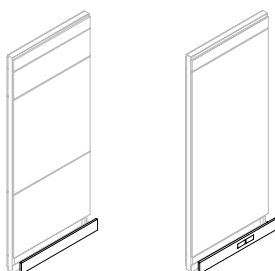

F P R C Fabric Wrapped Ceiling Fascia

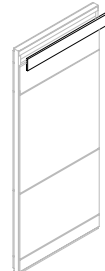

F P R M 1 Fabric Wrapped Fascia – Monolithic

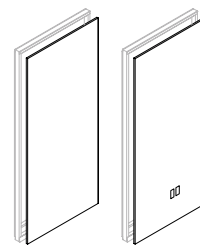

Portrait

fascias (continued)

F P R F 1 Fabric Wrapped Fascia – Full

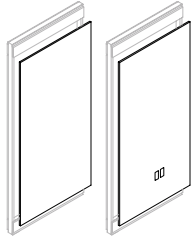

F P R S 1 Fabric Wrapped Fascia – Segmented (Level I)

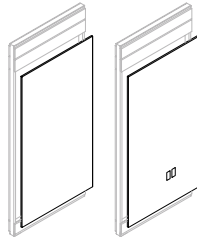

F P R S 2 Fabric Wrapped Fascia – Segmented (Level II)

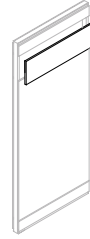

F P R S M 1 Fabric Wrapped Fascia – Segmented Monolithic (Level I)

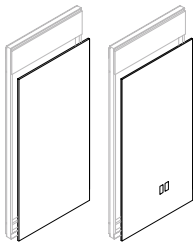

F P R S M 2 Fabric Wrapped Fascia – Segmented Monolithic (Level II)



F P R W 1 Fabric Wrapped Fascia – Working Wall (Level I)

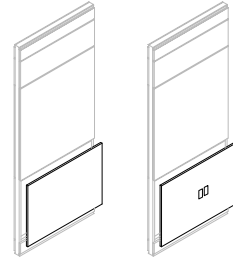

F P R W 2 Fabric Wrapped Fascia – Working Wall (Level II)

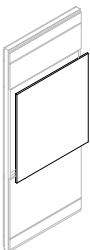

F P R W 3 Fabric Wrapped Fascia – Working Wall (Level III)

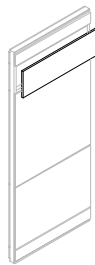

F P R W M 1 Fabric Wrapped Fascia – Working Wall Monolithic (Level I)

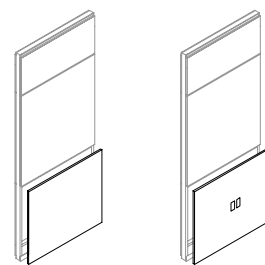

F P R W M 3 Fabric Wrapped Fascia – Working Wall Monolithic (Level III)

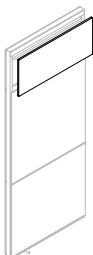

F P M A Smart Fascia – Accessory

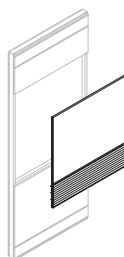

F P M W Smart Fascia – Whiteboard



Portrait

fascias (continued)

F P M T Smart Fascia – Tackable

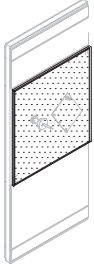

F P M M F Framed Backpainted Glass Markerboard



F D M M F D Framed Backpainted Glass – Markerboard Double Span

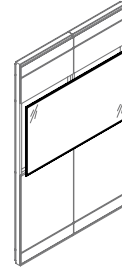

F F F K Aluminum Fascia Kit



Portrait

fascias (continued)

F L B Landscape Base Fascia

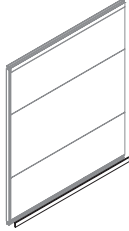

F L C Landscape Ceiling Fascia

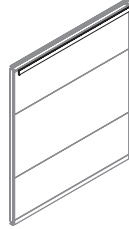

F L W 1 Landscape Solid Fascia – Working Wall (Level I)

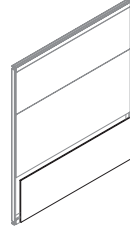

F L W 2 Landscape Solid Fascia – Working Wall (Level II)

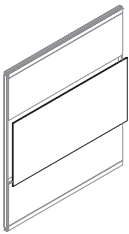

F L W 3 Landscape Solid Fascia – Working Wall (Level III)

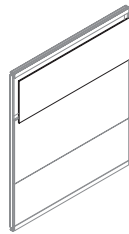

F L W M 1 Landscape Solid Fascia – Working Wall Monolithic (Level I)

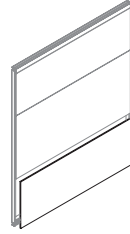

F L W M 3 Landscape Solid Fascia – Working Wall Monolithic (Level III)

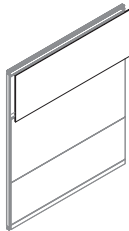

F L B W 1 Landscape Solid Fascia – Working Wall Bottom (Level I)

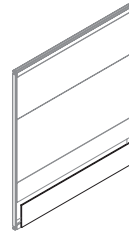

F L T W 1 Landscape Solid Fascia – Working Wall Top (Level I)

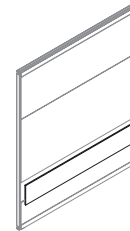

FLBWM 1 Landscape Solid Fascia – Working Wall Monolithic Bottom (Level I)

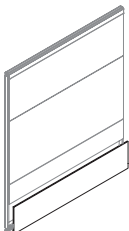

F L B W 2 Landscape Solid Fascia – Working Wall Bottom (Level II)

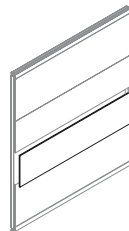

F L T W 2 Landscape Solid Fascia – Working Wall Top (Level II)

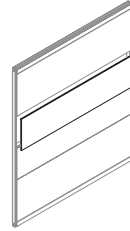

Landscape

fascias (continued)

**F L R B Landscape Fabric
Wrapped Base Fascia**



**F L R C Landscape Fabric
Wrapped Ceiling Fascia**



**F L R W 1 Landscape Fabric
Wrapped Fascia
(Level I)**

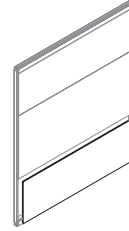

**F L R W 2 Landscape Fabric
Wrapped Fascia
(Level II)**

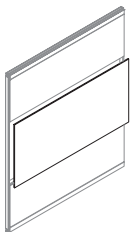

**F L R W 3 Landscape Fabric
Wrapped Fascia
(Level III)**

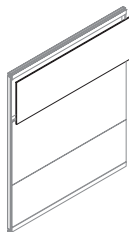

**F L R W M 1 Landscape Fabric
Wrapped Fascia –
Working Wall
Monolithic (Level I)**

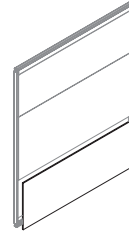

**F L R W M 3 Landscape Fabric
Wrapped Fascia –
Working Wall
Monolithic (Level
III)**

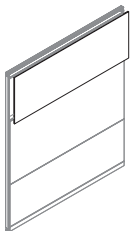

**F L R B W 1 Landscape Fabric
Wrapped Fascia –
Working Wall
Bottom (Level I)**

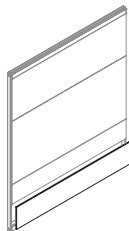

**F L R T W 1 Landscape Fabric
Wrapped Fascia –
Working Wall Top
(Level I)**

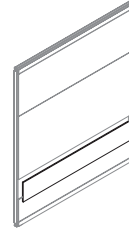

**F L R B W M 1 Landscape
Fabric Wrapped Fascia –
Working Wall Monolithic
Bottom (Level I)**

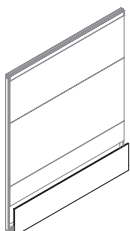

**F L R B W 2 Landscape Fabric
Wrapped Fascia –
Working Wall
Bottom (Level II)**

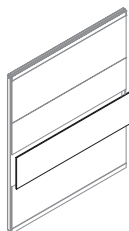

**F L R T W 2 Landscape Fabric
Wrapped Fascia –
Working Wall Top
(Level II)**

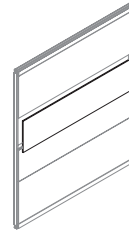

Landscape

fascias (continued)

F L A T W 1 Landscape Acoustic Tackable Fascia (Level I)

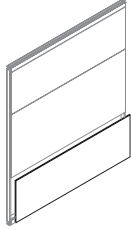

F L A T W 2 Landscape Acoustic Tackable Fascia (Level II)

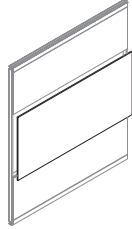

F L A T W 3 Landscape Acoustic Tackable Fascia (Level III)

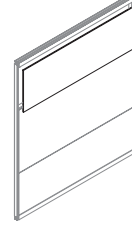

F L A T B W 1 Landscape Acoustic Tackable Fascia – Working Wall Bottom (Level I)

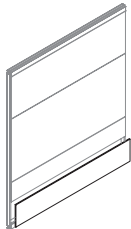

F L A T T W 1 Landscape Acoustic Tackable Fascia – Working Wall Top (Level I)

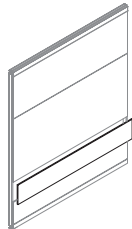

F L A T B W 2 Landscape Acoustic Tackable Fascia – Working Wall Bottom (Level II)

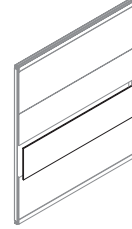

F L A T T W 2 Landscape Acoustic Tackable Fascia – Working Wall Top (Level II)

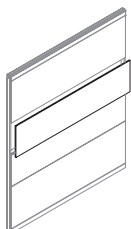

F L M P W 1 Landscape Micro Perforated Sheet Metal Fascia (Level I)

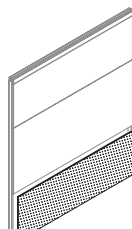

F L M P W 3 Landscape Micro Perforated Sheet Metal Fascia (Level III)

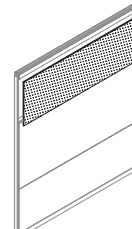

F L M P B W 1 Landscape Micro Perforated Metal Acoustic Fascia – Working Wall Bottom (Level I)

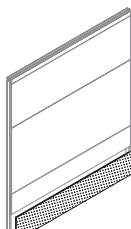

F L M P T W 1 Landscape Micro Perforated Metal Acoustic Fascia – Working Wall Top (Level I)

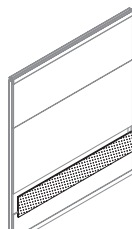

F L M P B W 2 Landscape Micro Perforated Metal Acoustic Fascia – Working Wall Bottom (Level II)

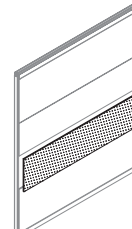

Landscape

fascias (continued)

F L M P T W 2 Landscape Micro Perforated Metal Acoustic Fascia – Working Wall Top (Level II)

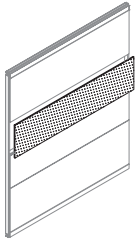

F L M B W 1 Landscape Metal Backer – Working Wall (Level I)

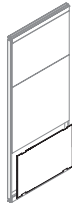

F L M B W 3 Landscape Metal Backer – Working Wall (Level III)

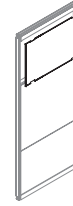

F L M B B W 1 Landscape Metal Backer Bottom (Level I)

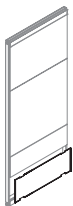

F L M B T W 1 Landscape Metal Backer Top (Level I)

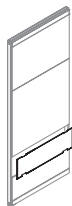

F L M B B W 2 Landscape Metal Backer Bottom (Level II)



F L M B T W 2 Landscape Metal Backer Top (Level II)

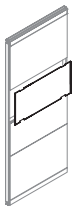

F L M W N Landscape Markerboard Frameless



F L M M F Landscape Markerboard Framed

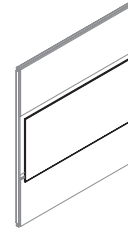

F L F K Landscape Aluminum Fascia Kit



F L G C Landscape Glazed Fascia Single Centered

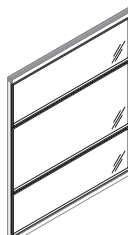

F L G D Landscape Glazed Fascia Double



fascias (continued)

F L D F W 1 Landscape Fixed Desk Fascia (Level I)

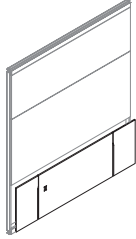

F L D F W M 1 Landscape Fixed Desk Fascia – Working Wall Monolithic (Level I)

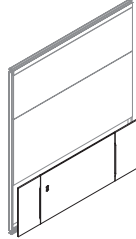

F L D H W 1 Landscape Height-Adjustable Desk Fascia (Level I)

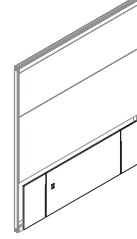

F L D H W M 1 Landscape Height-Adjustable Desk Fascia – Working Wall Monolithic (Level I)

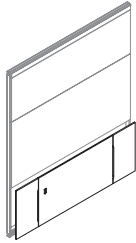

F L J B Landscape Justified Base Fascia

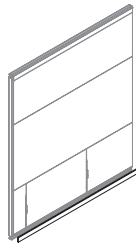

F L J C Landscape Justified Ceiling Fascia



F L J W 2 Landscape Justified Solid Fascia – Working Wall (Level II)

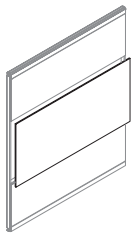

F L J W 3 Landscape Justified Solid Fascia – Working Wall (Level III)

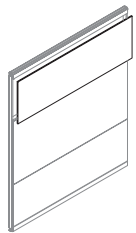

F L J W M 3 Landscape Justified Solid Fascia – Working Wall Monolithic (Level III)

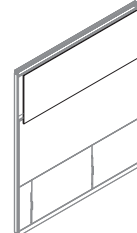

F L J B W 2 Landscape Justified Solid Fascia – Working Wall Bottom (Level II)

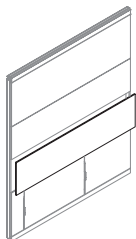

F L J T W 2 Landscape Justified Solid Fascia – Working Wall Top (Level II)

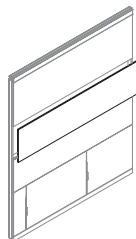

F L J R B Landscape Justified Fabric Wrapped Base Fascia

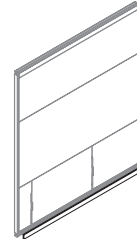

Landscape

fascias (continued)

FLJRC Landscape Justified Fabric Wrapped Ceiling Fascia



FLJRW2 Landscape Justified Fabric Wrapped Fascia – Working Wall (Level II)

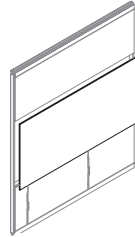

FLJRW3 Landscape Justified Fabric Wrapped Fascia – Working Wall (Level III)

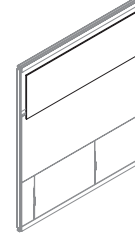

FLJRW M3 Landscape Justified Fabric Wrapped Fascia – Working Wall Monolithic (Level III)

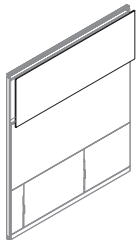

FLJRBW2 Landscape Justified Fabric Wrapped Fascia – Working Wall Bottom (Level II)

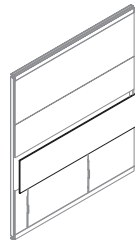

FLJRTW2 Landscape Justified Fabric Wrapped Fascia – Working Wall Top (Level II)

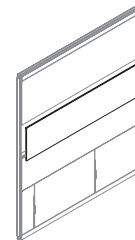

FLJATW2 Landscape Justified Acoustic Tackable Fascia – Working Wall (Level II)

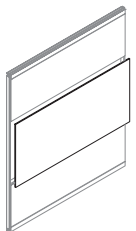

FLJATW3 Landscape Justified Acoustic Tackable Fascia – Working Wall (Level III)

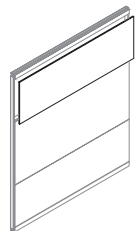

FLJATBW2 Landscape Justified Acoustic Tackable Fascia – Working Wall Bottom (Level II)

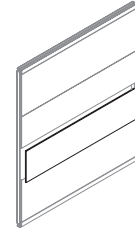

FLJATTW2 Landscape Justified Acoustic Tackable Fascia – Working Wall Top (Level II)

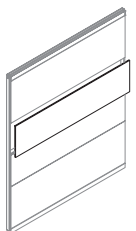

FLJMPBW2 Landscape Justified Micro Perforated Metal Acoustic Fascia Bottom (Level II)

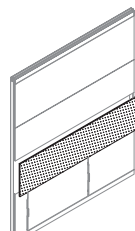

FLJMPTW2 Landscape Justified Micro Perforated Metal Acoustic Fascia Top (Level II)

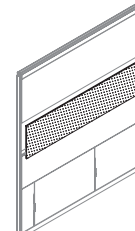

Landscape

fascias (continued)

F L J M P W 3 Landscape
Justified Micro Perforated
Metal Acoustic Fascia
(Level III)

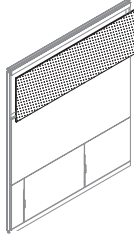

F L J M B B W 2 Landscape
Justified Metal Backer
Bottom (Level II)

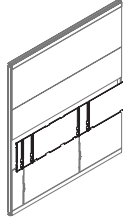

F L J M B T W 2 Landscape
Justified Metal Backer Top
(Level II)

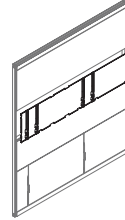

F L J M B W 3 Landscape
Justified Metal Backer
(Level III)

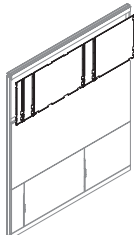

F L J M W N Landscape Justified
Markerboard Frameless

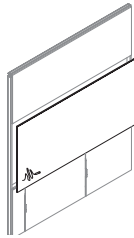

F L J M M F Landscape Justified
Markerboard Framed

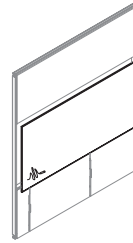

Landscape

fascias (continued)

Portrait & Landscape

F P F Filler Panel

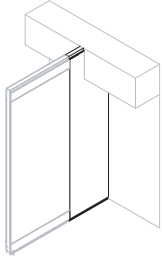

F K C N 9 0 Two-Way 90°
Corner Cover

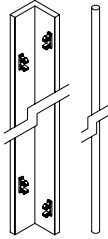

F K C N 1 2 0 Two-Way 120°
Corner Cover

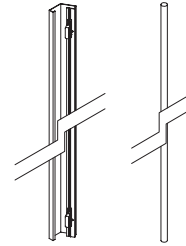

F K C N 1 3 2 Two-Way 135°
Corner Cover

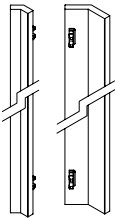

F K C N 1 3 3 Three-Way 135°
Corner Cover

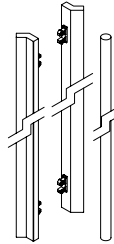

F K C N 1 8 0 Three-Way 180°
Corner Cover

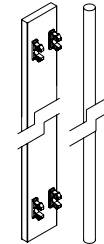

door packages

F P D H Hinged Door – Solid

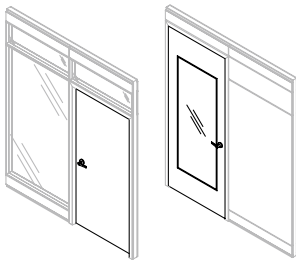

Right Swing Segmented Left Swing Full-Height

F D H Hinged Door

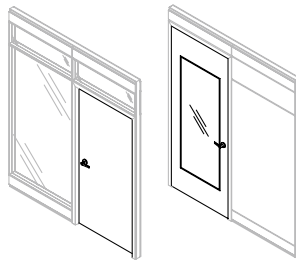

Right Swing Segmented Left Swing Full-Height

F P D P Z Framed Glass Door – Pivot Low Profile

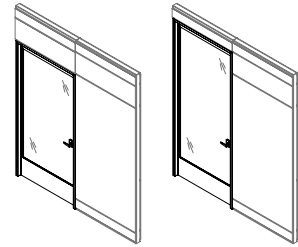

Segmented Full-Height

F D P Z Framed Glass Pivot Door

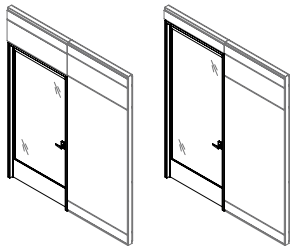

Segmented Full-Height

F P D J Hinged Door – Glass

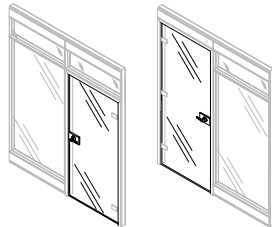

Right Swing Segmented Left Swing Full-Height w/ Glass Insert

F D J Hinged Glass Door

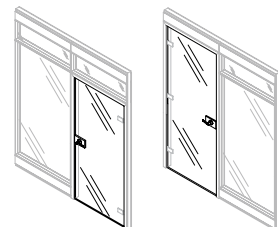

Right Swing Segmented Left Swing Full-Height w/ Glass Insert

F P D E Hinged Double Door – Glass

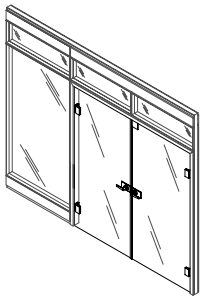

F D E Hinged Glass Double Door

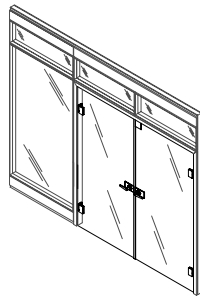

F P D D Hinged Double Door – Solid

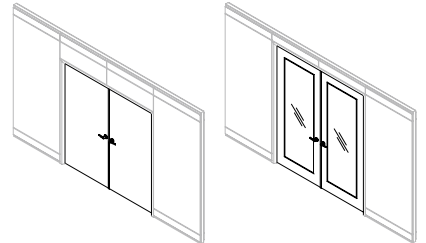

Solid Segmented Glass Insert Full-Height

F D D Hinged Double Door

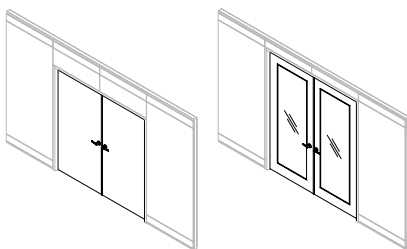

Solid Segmented Glass Insert Full-Height

F D C Glass Barn Door

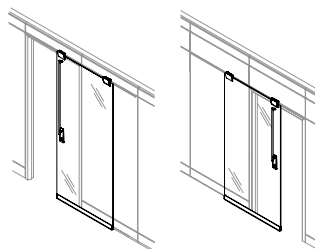

Right Slide Full-Height Left Slide Segmented

F D C Z Glass Barn Door Low Profile

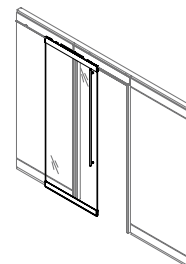

door packages (continued)

F D S Solid Barn Door

F D I Barn Door with Glass Insert

F D L Double Glass Barn Door

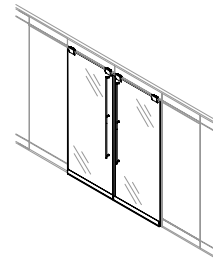
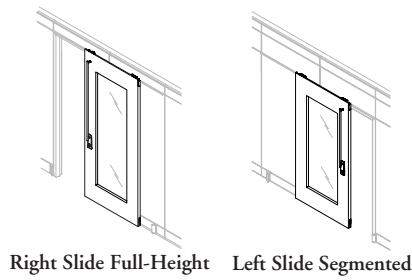
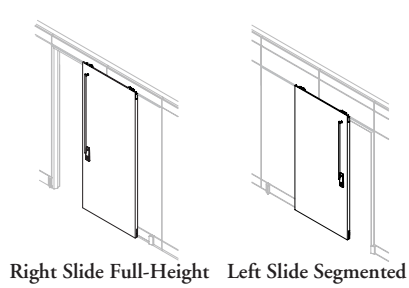

**F D L Z Double Glass Barn Door
Low Profile**

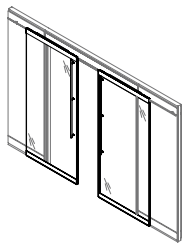

frame kits & components

F K N Ceiling Channel

Xpress

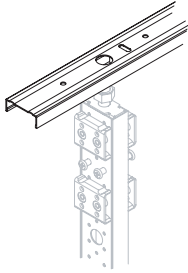

F K C Base Channel – Continuous

Xpress

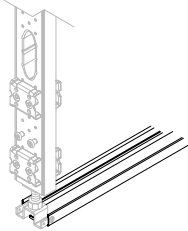

F K P Ceiling Clips

Xpress

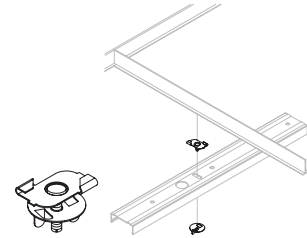

F P K K Horizontal Rail

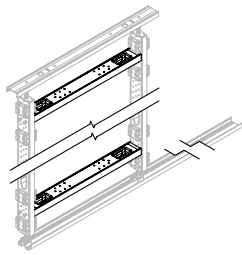

F P K H Horizontal Rail Packages

Xpress

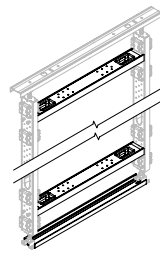

F K V Vertical Post Packages

Xpress

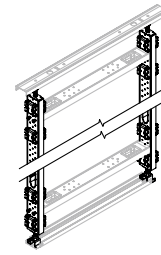

F K W Wall Start

Xpress

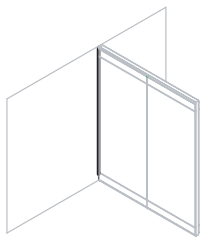

F P K W Adjustable Wall Start

Xpress

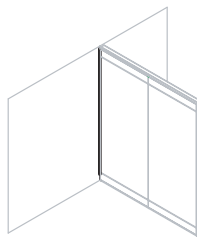

F K E Adjustable Wall End

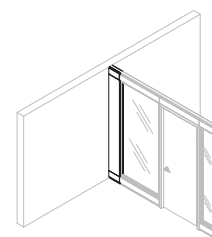

F K W A Variable Angle Wall Start

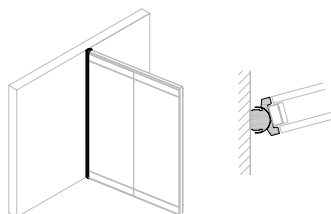

F K F Wall Finished End

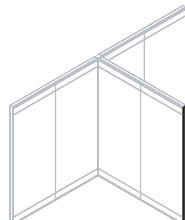

F K C H Hardware for Altos Corner Connections

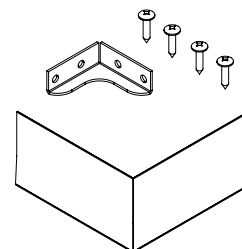

frame kits & components (continued)

F K C 4 Four-Way Connection

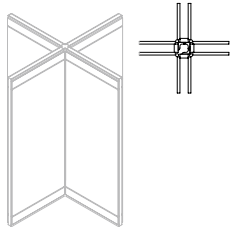

F K C A 2 Articulating Two-Way Corner

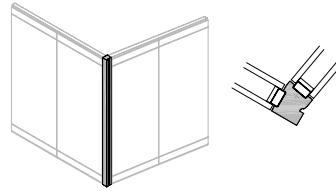

F K C A 3 Articulating Three-Way Corner

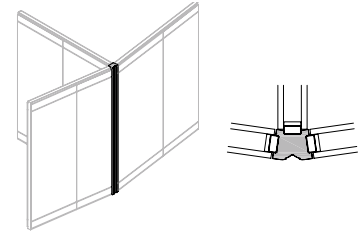

F K M 3 Three-Way 180° Module Connection

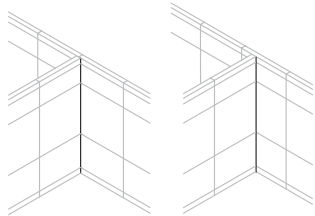

On-Module Off-Module

F K J Wall Gasket

Xpress

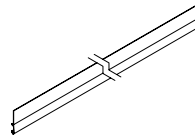

F K J C Vertical Reveal Corner Kit

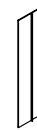

F K T F Double Door Frame Package – Full-Height



F K T S Double Door Transom & Frame Package – Segmented-Height



F P F E S Hinged Double Door Transom & Frame – Glass Segmented Height



F K T E S Hinged Glass Double Door Transom & Frame Package – Segmented-Height

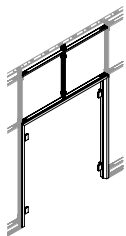

F K D Door Frame Kit

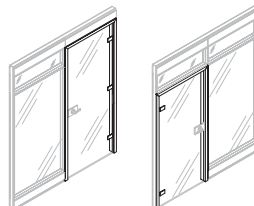

F P U G F R Barn Door Rail Kit for Full Height Door – Low Profile



frame kits & components (continued)

F P U G F J Barn Door Jamb Kit for Full Height Glass Door – Low Profile

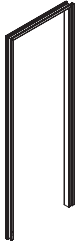

F P B F R Barn Door Rail Kit for Full-Height Door

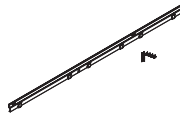

F P B S F J Barn Door Jamb Kit for Full-Height Solid Door



F P B G F J Barn Door Jamb Kit for Full-Height Glass Door

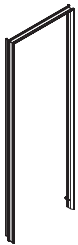

F P B S R Barn Door Rail Kit for Segmented-Height Door



F P B S S J Barn Door Jamb Kit for Segmented-Height Solid Door



F P B G S J Barn Door Jamb Kit for Segmented-Height Glass Door

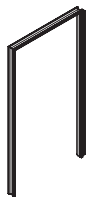

F P L G F R Double Barn Door Rail Kit for Full-Height Door



F P L G F J Double Barn Door Jamb Kit for Full-Height Glass Door

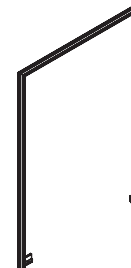

F P V G F R Double Barn Door Rail Kit for Full-Height Door – Low Profile



F P V G F J Double Barn Door Jamb Kit for Full-Height Glass Door – Low Profile



F K P S Z Glass Pivot Door Solid Frame Kit

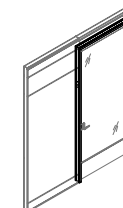

frame kits & components (continued)

F P F P S Framed Pivot Door Frame – Low Profile



F P F H S Hinged Door Frame – Solid



F P F J S Hinged Door Frame – Low Profile



F P F D S Hinged Double Door Frame – Solid

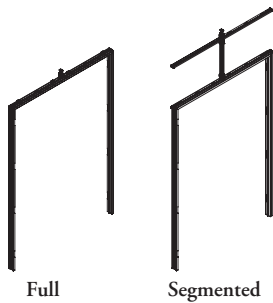

F T T Installation Tools

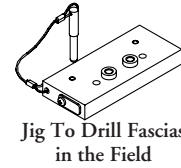
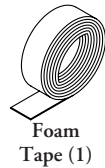
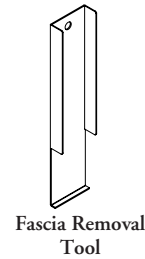

F B G Horizontal Grommet

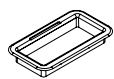

F A I Recycled Cotton Insulation

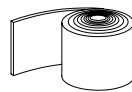

F B B Base Leveler

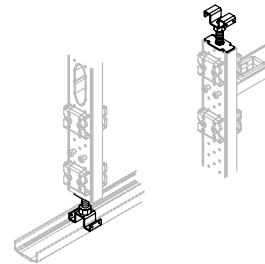

F B E Horizontal End Cap

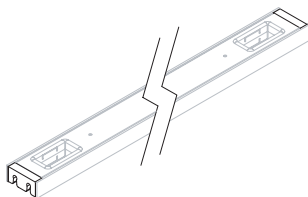

F B N Horizontal Connector Bolt

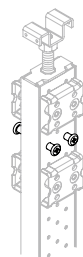

F B F M Fascia Connector – Male

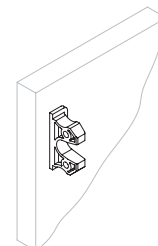

frame kits & components (continued)

F B F F Fascia Connector – Female

F K L Fascia Lock

F P K B Base Channel – Modular

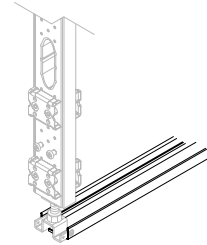
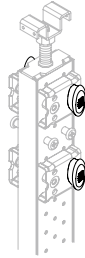
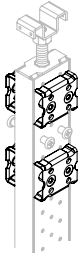

F L K F Landscape Functional Rail Kit

F L K H Landscape Horizontal Rail Package

F L K V Landscape Vertical Post Package

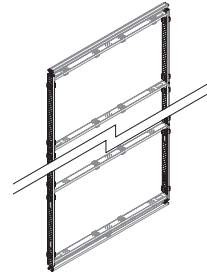
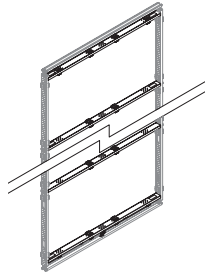
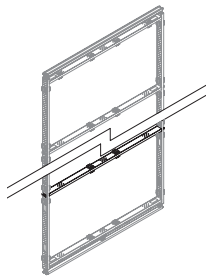

F L K V P Landscape to Portrait Vertical Post Package

F L K W Landscape Adjustable Wall Start

F L D F Landscape Desk Frame

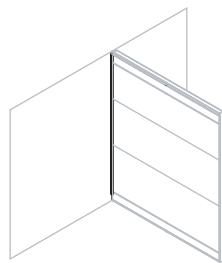
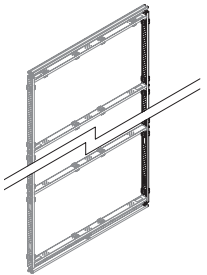

F L B F R Landscape Barn Door Rail Kit for Full-Height Door

F L B G F J Landscape Barn Door Jamb Kit for Full-Height Glass Door

F L U G F R Landscape Barn Door Rail Kit for Full-Height Door – Low Profile



frame kits & components (continued)

FLUGFJ Landscape Barn Door
Jamb Kit for Full-
Height Glass Door –
Low Profile

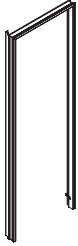

FLBSR Landscape Barn Door
Rail Kit for Segmented-
Height Door



FLBGSJ Landscape Barn
Door Jamb Kit for
Segmented-Height
Glass Door



tek pier – portrait

F K T K P Frame Assembly for Tek Pier

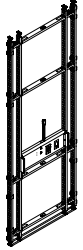

F F M T K P Monolithic Fascia

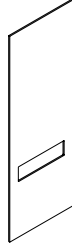

F F F T K P Full Fascia Kit

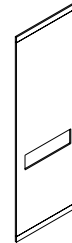

F F S T K P Segmented Fascia Kit

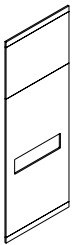

F F S M T K P Segmented Monolithic Fascia Kit

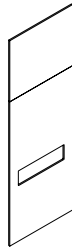

F F C B T K P 4" Base and Ceiling Fascia Kit for Tek Pier (Opposite Side)



T K P 1 Tek Pier Assembly 1

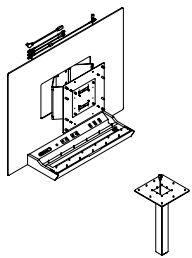

T K P 2 Tek Pier Assembly 2

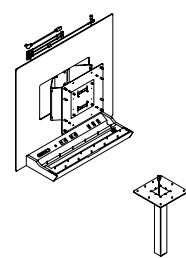

T K P A Spade Top Worksurface

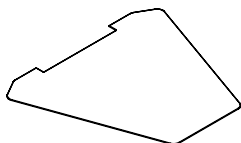

T K P B Pie Top Worksurface

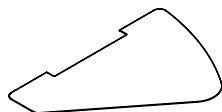

T K P C Wedge Top Worksurface

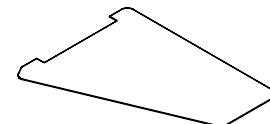

lighting, electrics & communications

Hardwire

E L S Light Switch

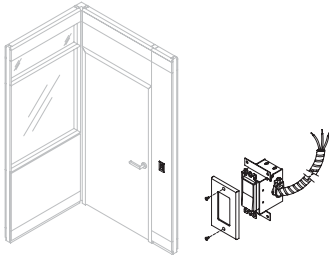

E R M Receptacle Module

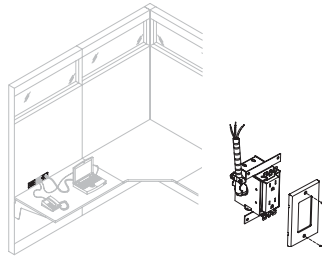

E C M Communications Module

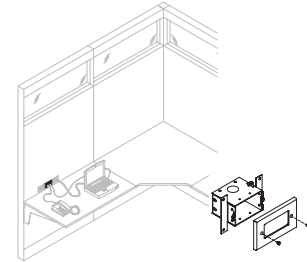

E R C Communications Box

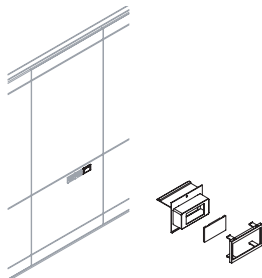

E R A S Single Power Box

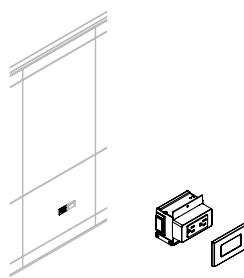

E R A D Double Power Box

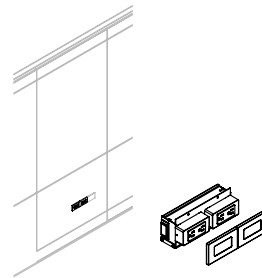

E R A B Two-Sided Power Box

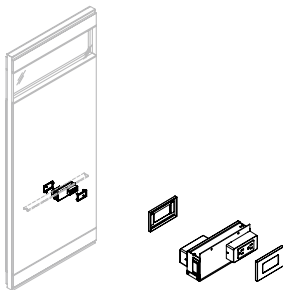

E B Power Harness

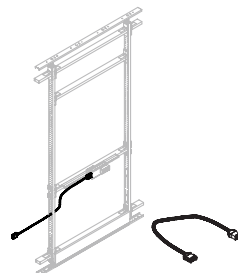

E B T Transition Harness

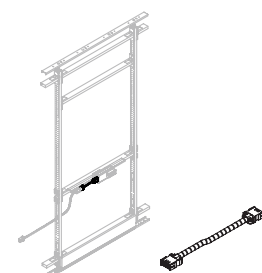

E C F Ceiling/Underfloor Feed

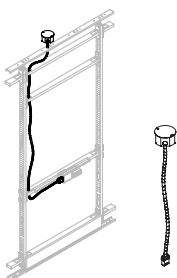

E F A Modular Power Distribution Box

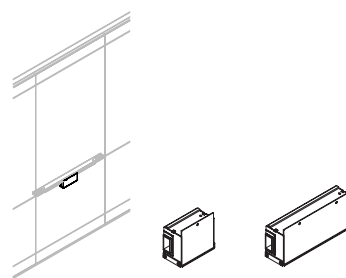

E M R Mounting Rail

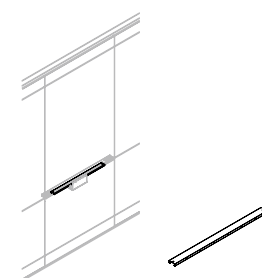

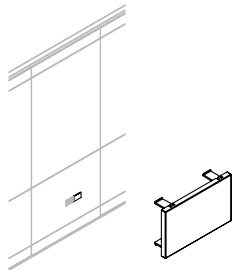
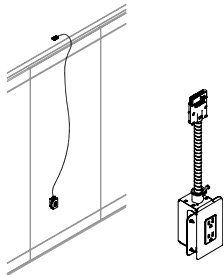
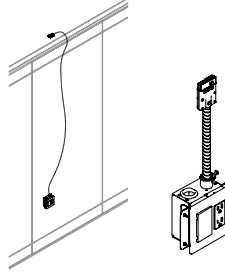
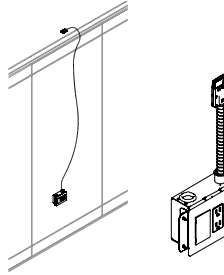
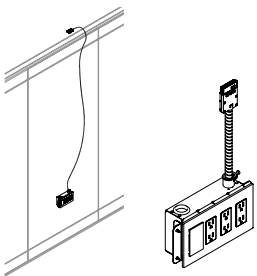
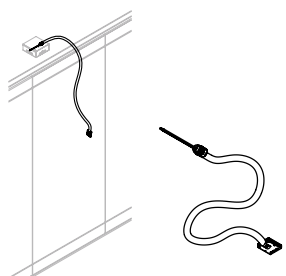
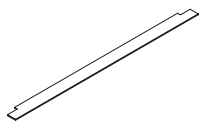
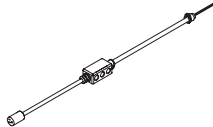
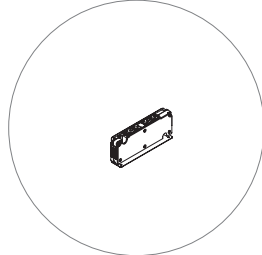

Modular

lighting, electrics & communications (continued)

Modular	E F C C Fascia Cover Cap		
			
Power Plus	E R G M S Power Plus Communication Module – Single	E R G M D Power Plus Communication Module – Double	E R G M T Power Plus Communication Module – Triple
			
	E R G M Q Power Plus Communication Module – Quad	E R S C Power Plus Communication Module Starter Cable	
			
Landscape	E L W M L Landscape Wall-Mounted Light	E L P F Light Power Feed	E L W D B In-Wall Distribution Box
			

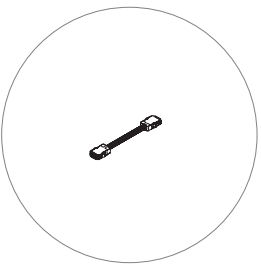
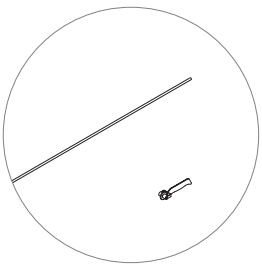
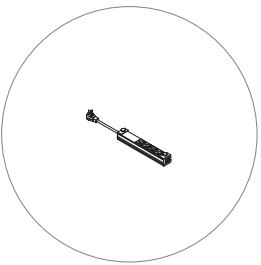
lighting, electrics & communications (continued)

Landscape	<p>E L D H Landscape Desk Connecting Harness</p> 	<p>E L W M G Landscape Light Wire Management</p> 
Power Accessories	<p>E L P R Power Rod</p> 	<p>E P W R C Power Cube</p> 

mounted storage & accessories – portrait

F M C H Coat Hook

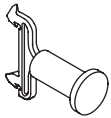

F M A H Art Hook



F M O S Office Signage

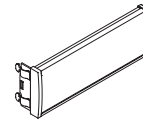

KT Touch-Up Kits

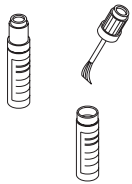

Small Brushes
(KT100)

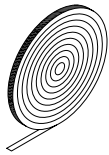

Edge Banding
(KT500)

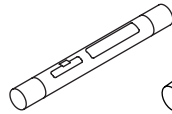

Crayon
(KT401)

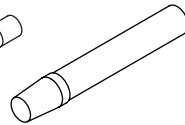

Marker
(KT402)

FLON On-Module Cantilever

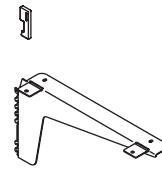

Right

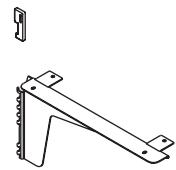

Left

TLFL Fixed Height Gable

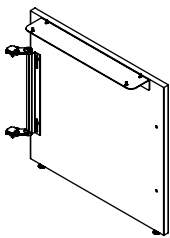

FLCB On-Module Corner Bracket

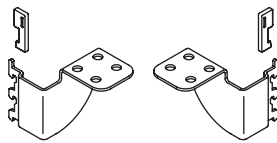

Left

Right

collection – landscape

F L D F X Landscape Desk Fixed

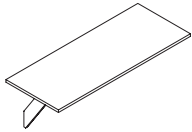

F L D F X C Landscape In-Wall Connection for Fixed Desk

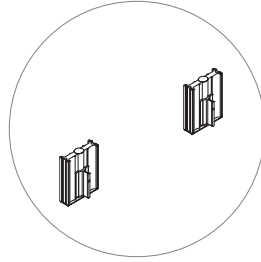

F L D H A Landscape Desk Height-Adjustable

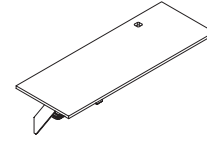

F L D H A C Landscape In-Wall Connection for Height-Adjustable Desk

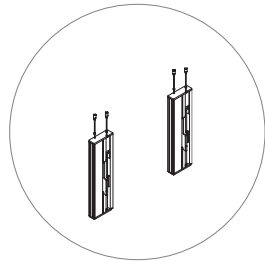

F L G R Rectangular Grommet

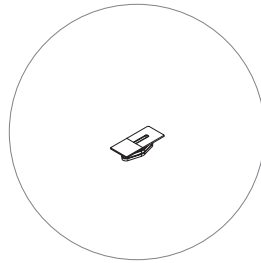

F L W C O Landscape Wall-Mounted Open Cabinet

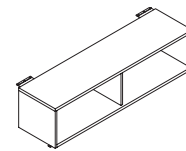

F L W C S Landscape Wall-Mounted Sliding Door Cabinet

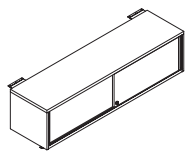

F L F C Landscape Fitted Seat Cushion

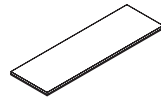

F L S A Landscape Shelf Aluminum

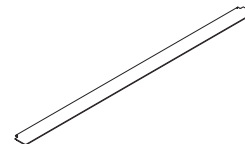

F L S G Landscape Shelf Glass

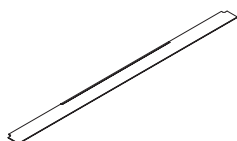

F L S S Landscape Shelf Solid

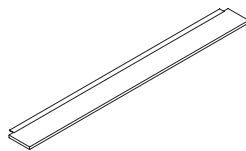

F L T W Landscape Tray Whiteboard

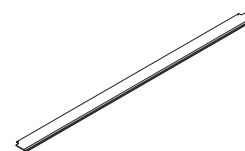

understanding portrait

understanding portrait

PLANNING POSSIBILITIES – PRIVATE OFFICE48

PLANNING POSSIBILITIES – EXECUTIVE OFFICE49

PLANNING POSSIBILITIES – BOARDROOM.50

PLANNING POSSIBILITIES – TRAINING ROOM51

portrait overview

Altos Portrait is a full height architectural wall system with vertically spanning fascias with the ability to create complete office environments. Portrait walls can be simply reconfigured and relocated in a cost-efficient manner as required.

- Altos readily furnishes privacy requirements in spaces like private offices, team rooms, boardrooms and shared workspaces
- Altos is designed so that its simple, clean aesthetic blends seamlessly with existing office environments and complements building interiors
- An array of Fascias provides many options to create stylish statements and to personalize the office aesthetic

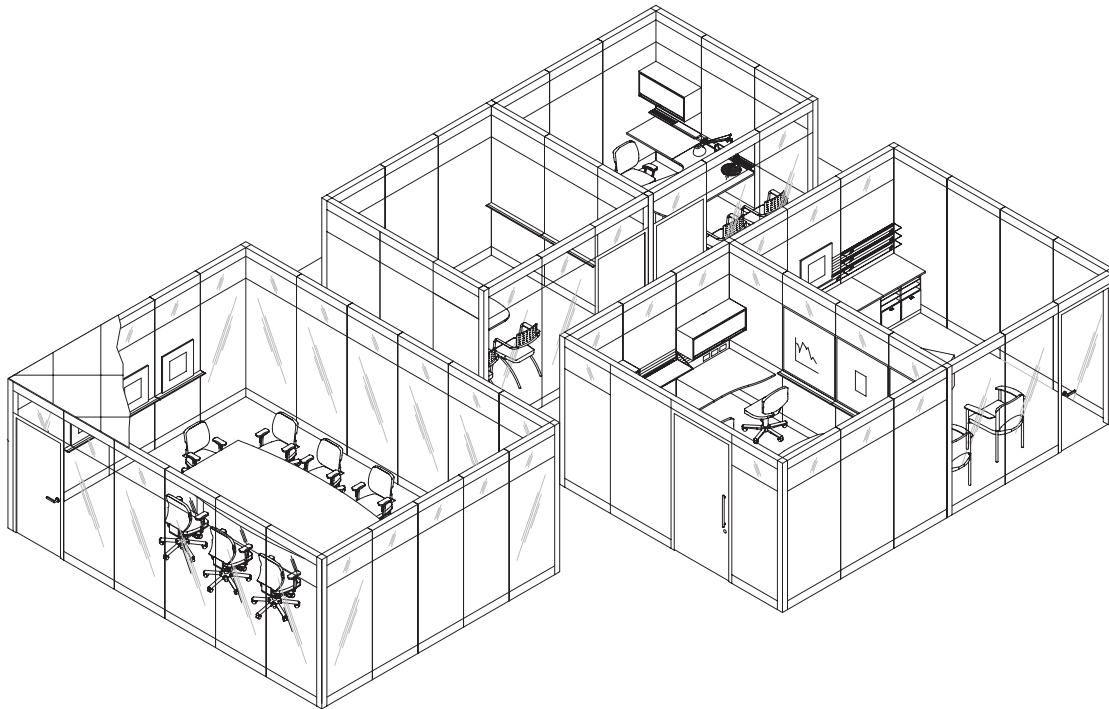

freestanding

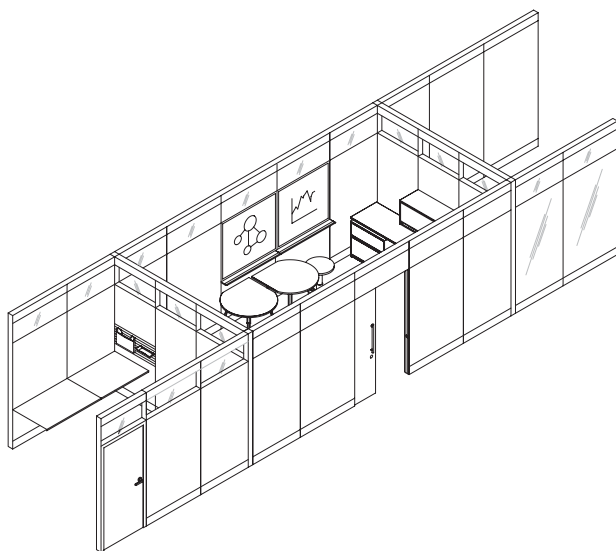

interface with building architecture

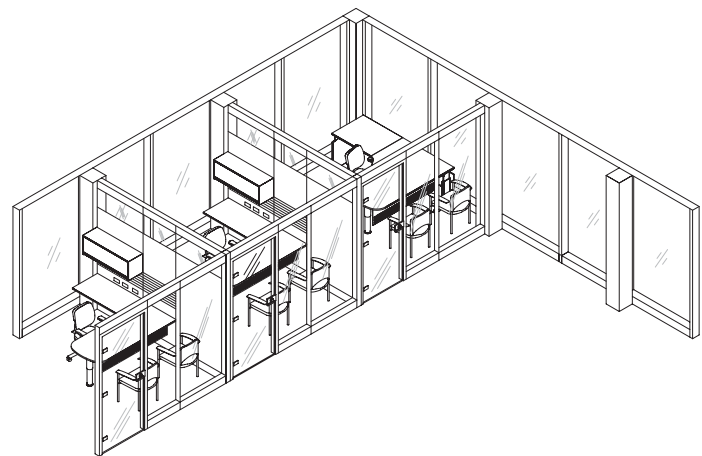

planning possibilities – private office

Full-height Altos walls combine privacy and elegance to respond to today's managerial needs.

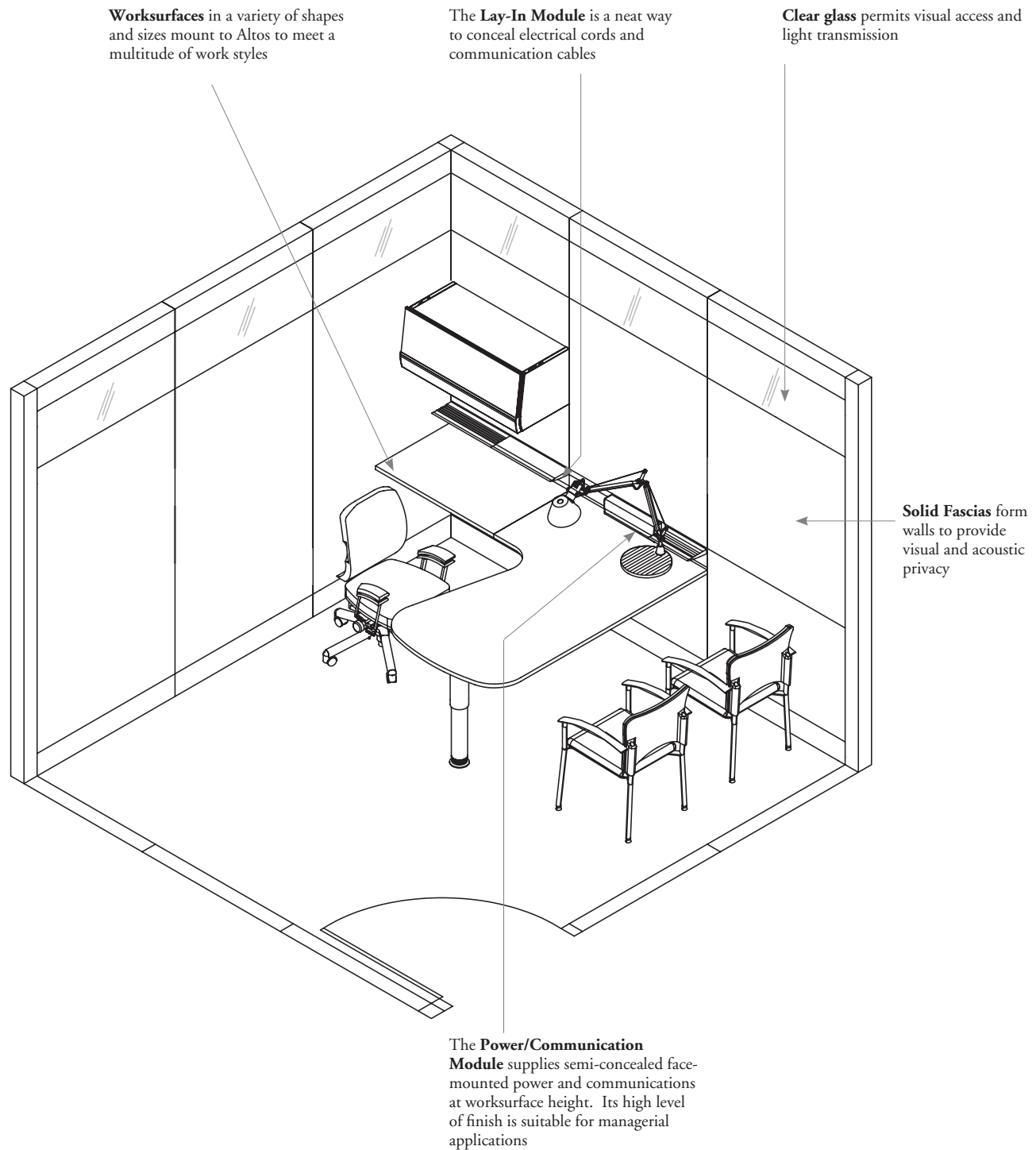

planning possibilities – executive office

The **Smart Fascia Accessory** suspends paper management accessories such as Personal Organizers, 3. and 6. Shelves for enhanced functionality

Glass Fascias at clerestory level permit light transmission while maintaining visual and acoustic privacy

Flintwood Veneers compliment the full range of Teknion executive offices

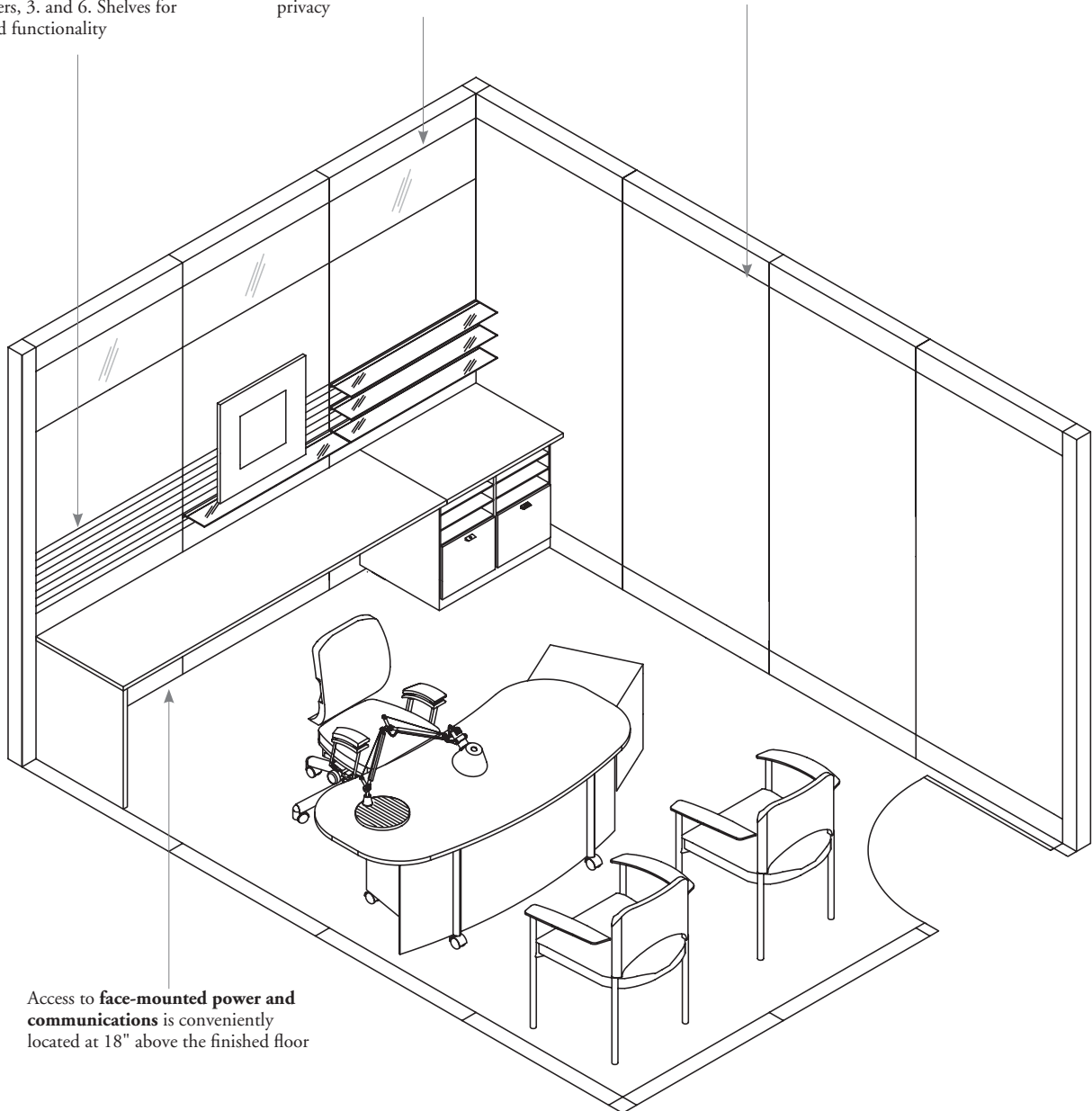

Access to **face-mounted power and communications** is conveniently located at 18" above the finished floor

planning possibilities – boardroom

Solid walls with glass at clerestory level allow light transmission while preserving visual and acoustic privacy. Glass can be specified as clear, frosted or architectural

Wall surface functionality is enhanced by mounted **3" Shelves** that provide a ledge for resting light objects or boards

A variety of wall widths are offered to attain varied dimensions, appropriate to boardrooms

Floor-to-ceiling **frosted glass** furnishes visual and acoustic privacy without sacrificing light

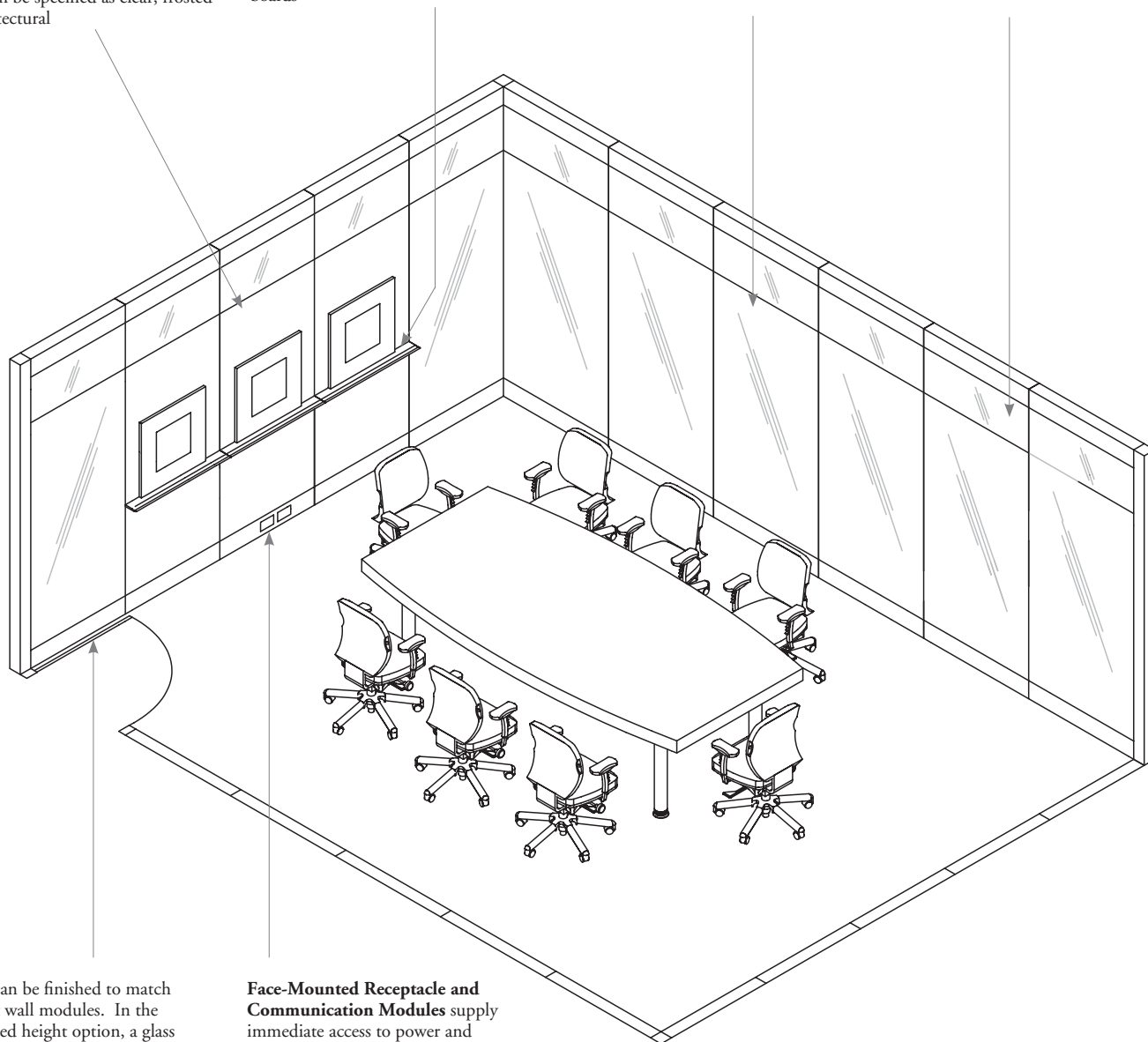

Doors can be finished to match adjacent wall modules. In the segmented height option, a glass transom permits light transmission

Face-Mounted Receptacle and Communication Modules supply immediate access to power and communications at base height

planning possibilities – training room

Altos configures simply and efficiently to address contemporary training requirements.

The **Smart Fascia - Tackable** displays paper-based information and the **Smart Fascia - Whiteboard** supplies an erasable surface to communicate concepts

Solid Fascias combined with clerestory glass create a focused learning environment while permitting light transmission and are available in finishes ranging from warm to cool hues. Integrated Smart Fascias maximize wall capabilities

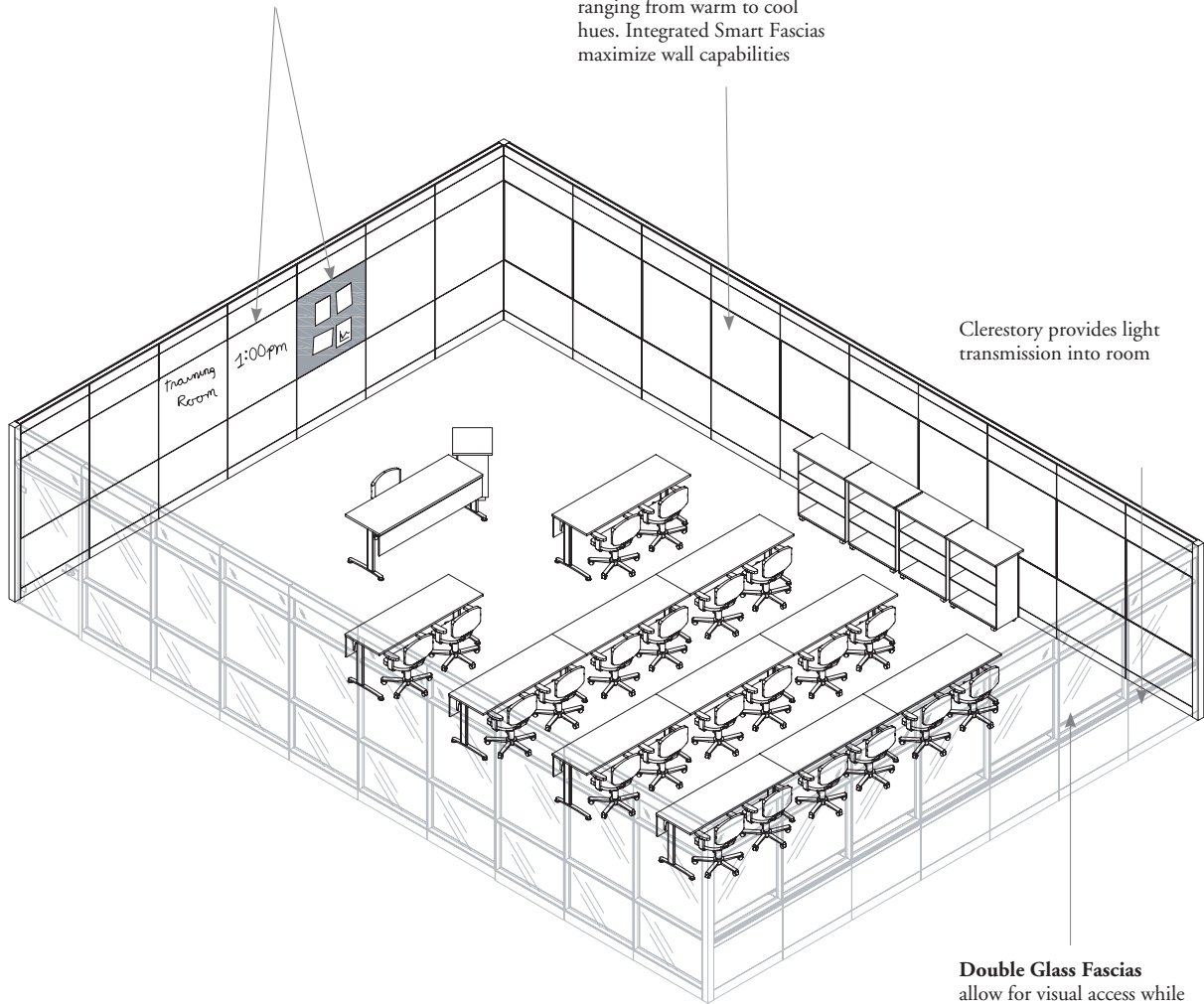

Clerestory provides light transmission into room

Double Glass Fascias allow for visual access while maintaining acoustic privacy

portrait – fascias

portrait – fascias

FASCIA ELEVATION OVERVIEW	54
SPECIFYING FASCIA HEIGHTS	56
PLANNING WITH FASCIAS	58
SPECIFYING FASCIAS WIDTHS	59
PLANNING WITH FASCIA WIDTHS	60
PLANNING WITH ACOUSTIC & FABRIC WRAPPED FASCIAS	61
SMART FASCIA BASICS	62
PLANNING WITH SMART FASCIAS	63
FILLER PANEL BASICS	64
FASCIA FINISHES - PORTRAIT	65

fascia elevation overview

Fascias are used to create the faces of Altos walls and are configured into four wall types depending on the Fascia selection.

- Fascias are available in a variety of solid and glass finishes that correspond to the selected wall elevation
- Fascias are built-up to complete the front and back elevation of a wall module and solid Fascias do **not** need to be identical
- Power and communication receptacle cut outs can be specified with solid and fabric wrapped Fascias, except 4" base fascias
- The structural members are **not** included with all Fascias
- Wall elevation types must be installed from floor to ceiling
- Fascias are available in widths from 12" – 48" in 1/8" increments
- Acoustic Fascias are **not** available for base, ceiling or W3, S2 fascias below 12" in height; use Fabric Wrapped fascias in these applications
- The 4" and 6" base and ceiling **cannot** be mixed; both **must** be 4" or 6" only

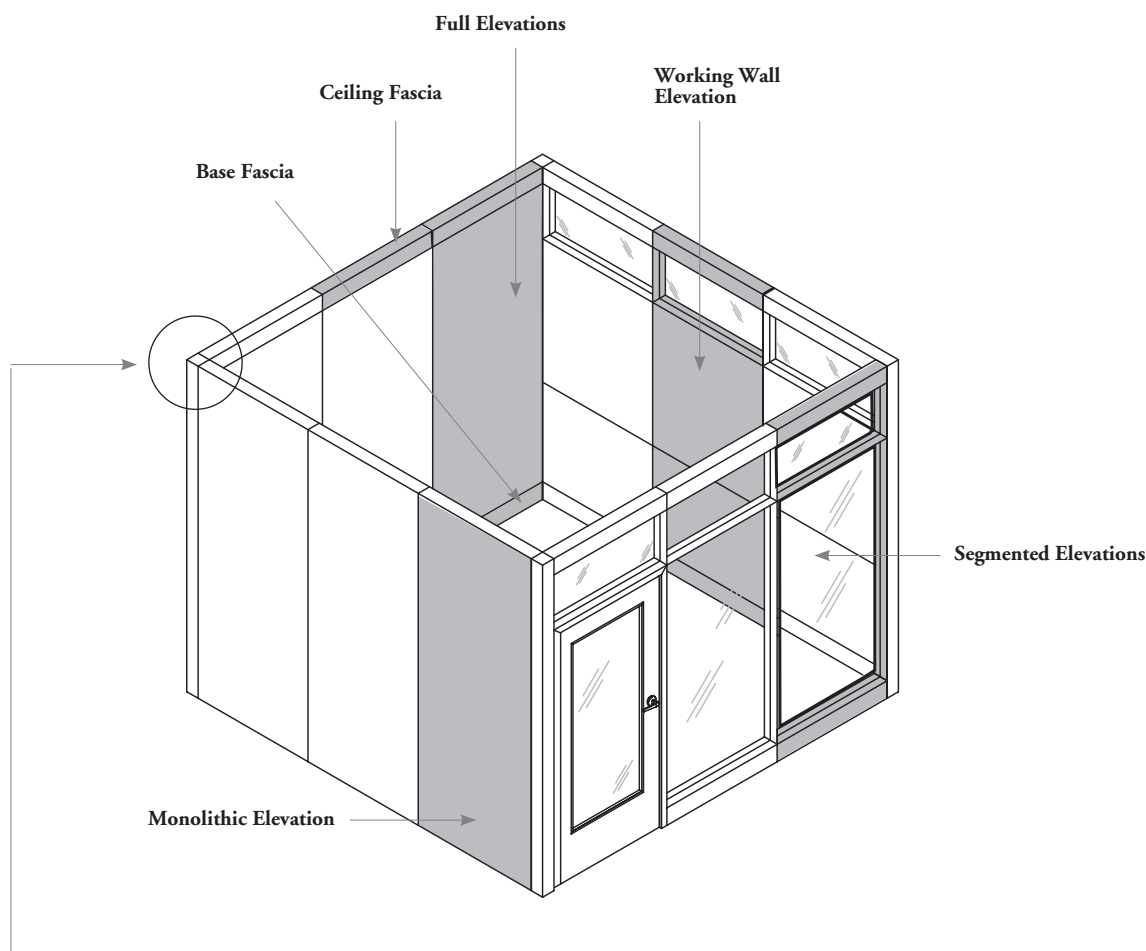

Also available but not shown:

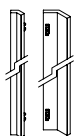

Two-Way 135° Corner Cover (FKCN132)
Provides a full-height trim for two walls connected at 135°

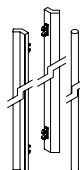

Three-Way 135° Corner Cover (FKCN133)
Provides a full-height trim for three walls connected at 135°

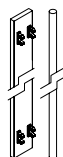

Three-Way 180° Corner Cover (FKCN180)
Provides the full-height trim for three walls connected at 180°

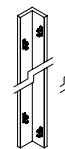

Two-Way 90° Corner Cover (FKCN90)
Provides the full-height trim for two walls connected at 90° at Two-Way Connection 90° Corner

fascia elevation overview (continued)

Possible Configurations

Monolithic Elevation

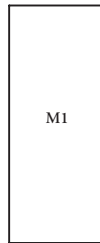

- Monolithic Fascias (M1):**
- Provides a single Fascia from floor-to-ceiling
 - No Base or Ceiling Fascia

Full Elevations

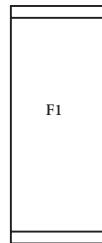

- Full Fascias (F1):**
- One surface Fascia between the 4" or 6" Base and Ceiling Fascias

Segmented Elevations

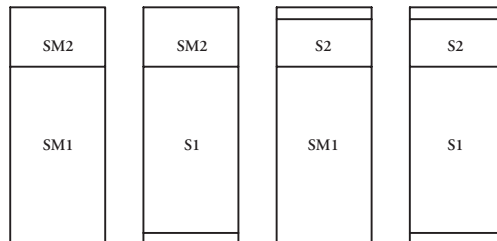

- Segmented Fascias (S1, S2):**
- Two surface Fascias between the 4" or 6" Base and Ceiling Fascias

- Segmented Monolithic Fascias (SM1, SM2):**
- These Fascias incorporate the 4" or 6" Base or Ceiling Fascia

Working Wall Elevations

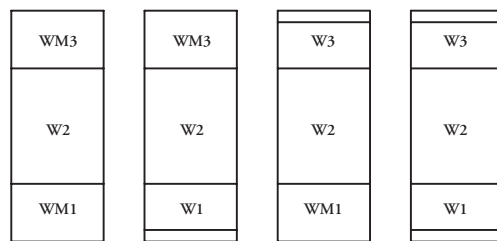

- Working Wall Fascias (W1, W2, W3):**
- Three surface Fascias between the 4" or 6" Base and Ceiling Fascias
 - Accommodates Smart Fascias

- Working Wall Monolithic Fascias (WM1, WM3):**
- These Fascias are used in conjunction with W2 Fascias and incorporate the 4" or 6" Base or Ceiling Fascia

Base Fascia and Ceiling Fascia



- Base Fascias:**
- Provides a solid flush finish at the bottom of a wall elevation
 - Accommodates base electrics and communications option
 - Two cut outs cannot be specified for Fascias less than 21" wide
 - Three cut outs cannot be specified for Fascias less than 30" wide
 - Can not be used with Monolithic Fascias



- Ceiling Fascia:**
- Provides a solid flush finish to the top of a wall elevation
 - Can not be used with Monolithic Fascias

specifying fascia heights

- To determine the correct height for Fascia F1 in the Full Configuration, Fascia S2 in the Segmented Configuration, and Fascia W3 in the Working Wall configuration, use the chart below
- One piece Glass Fascias are only available up to 112"

6" base and ceiling fascia

	Monolithic (M1)	Full (F1)	Segmented (S2)	Segmented Monolithic (SM2)	Working (W3)	Working Monolithic (WM3)
Ceiling Height (")	X"	X"	X"	X"	X"	X"
86	86	74	n/a	n/a	n/a	n/a
87	87	75	n/a	n/a	n/a	n/a
88	88	76	n/a	n/a	n/a	n/a
89	89	77	n/a	n/a	n/a	n/a
90	90	78	n/a	6*	n/a	6*
91	91	79	n/a	7*	n/a	7*
92	92	80	n/a	8*	n/a	8*
93	93	81	n/a	9*	n/a	9*
94	94	82	n/a	10*	n/a	10*
95	95	83	n/a	11*	n/a	11*
96	96	84	6	12	6	12
97	97	85	7	13	7	13
98	98	86	8	14	8	14
99	99	87	9	15	9	15
100	100	88	10	16	10	16
101	101	89	11	17	11	17
102	102	90	12	18	12	18
103	103	91	13	19	13	19
104	104	92	14	20	14	20
105	105	93	15	21	15	21
106	106	94	16	22	16	22
107	107	95	17	23	17	23
108	108	96	18	24	18	24
109	109	97	19	25	19	25
110	110	98	20	26	20	26
111	111	99	21	27	21	27
112	112	100	22	28	22	28
113	113	101	23	29	23	29
114	114	102	24	30	24	30
115	115	103	25	31	25	31
116	116	104	26	32	26	32
117	117	105	27	33	27	33
118	118	106	28	34	28	34
119	119	107	29	35	29	35
120	120	108	30	36	30	36

* This size is available for selected finishes. See product pages for size availability.

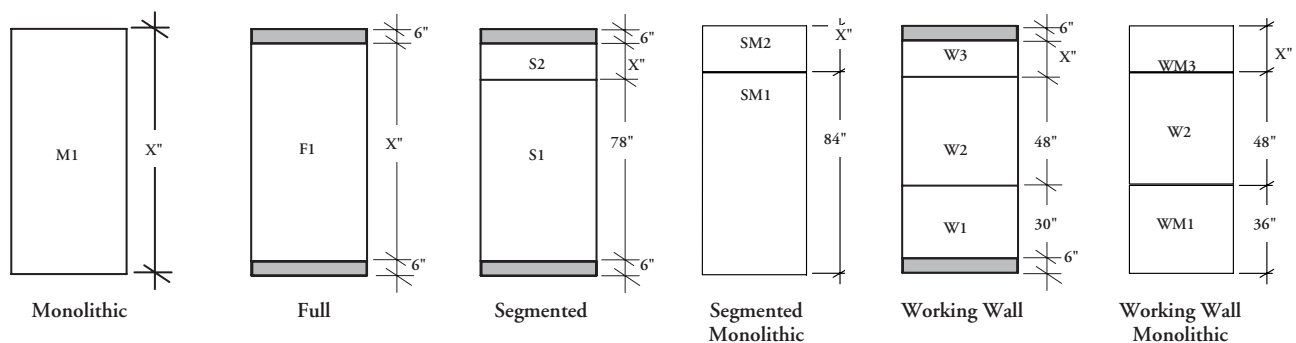

specifying fascia heights (continued)

- To determine the correct height for Fascia F1 in the Full Configuration, Fascia S2 in the Segmented Configuration, and Fascia W3 in the Working Wall configuration, use the chart below
- One piece Glass Fascias are only available up to 112"

4" base and ceiling fascia

	Monolithic (M1)	Full (F1)	Segmented (S2)	Segmented Monolithic (SM2)	Working (W3)	Working Monolithic (WM3)
Ceiling Height (")	X"	X"	X"	X"	X"	X"
86	86	74	n/a	n/a	n/a	n/a
87	87	75	n/a	n/a	n/a	n/a
88	88	76	n/a	n/a	n/a	n/a
89	89	77	n/a	n/a	n/a	n/a
90	90	78	n/a	6*	n/a	6*
91	91	79	n/a	7*	n/a	7*
92	92	80	n/a	8*	n/a	8*
93	93	81	n/a	9*	n/a	9*
94	94	82	n/a	10*	n/a	10*
95	95	83	n/a	11*	n/a	11*
96	96	88	8	12	8	12
97	97	89	9	13	9	13
98	98	90	10	14	10	14
99	99	91	11	15	11	15
100	100	92	12	16	12	16
101	101	93	13	17	13	17
102	102	94	14	18	14	18
103	103	95	15	19	15	19
104	104	96	16	20	16	20
105	105	97	17	21	17	21
106	106	98	18	22	18	22
107	107	99	19	23	19	23
108	108	100	20	24	20	24
109	109	101	21	25	21	25
110	110	102	22	26	22	26
111	111	103	23	27	23	27
112	112	104	24	28	24	28
113	113	105	25	29	25	29
114	114	106	26	30	26	30
115	115	107	27	31	27	31
116	116	108	28	32	28	32
117	117	109	29	33	29	33
118	118	110	30	34	30	34
119	119	111	31	35	31	35
120	120	112	32	36	32	36

* This size is available for selected finishes. See product pages for size availability.

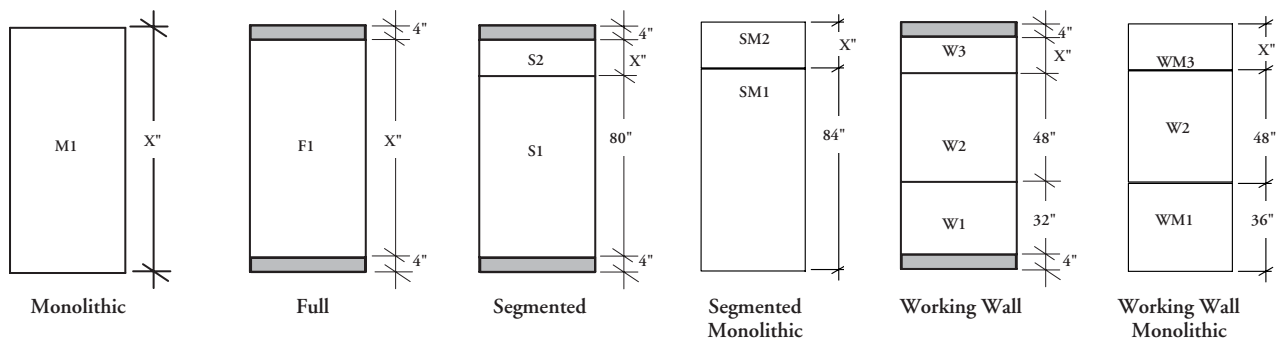

planning with fascias

Electrics and communications can be specified at three levels: base height, 18" height and worksurface height depending on type specified.

- Wall modules that require electrics or communications are specified by ordering Fascias that come complete with cut outs
- All cut outs are located right of center-line on the front of the Fascia – this allows for electrics and communications to be specified on both inner and outer elevations of the same wall module
- A Light Switch (ELS) can be installed on Solid Fascias. For more information on the Light Switch, refer to the guidelines, Lighting, Electrics and Communications section
- Electrics & Communications **cannot** be specified on Acoustic and Glass Fascias
- 4" base fascias **cannot** accept cut outs but wires can be routed through them

planning with the 4" fascia

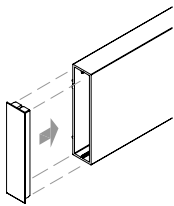

- On the Clear Anodized or Painted options - the plastic cap coordinates with the color of the fascia

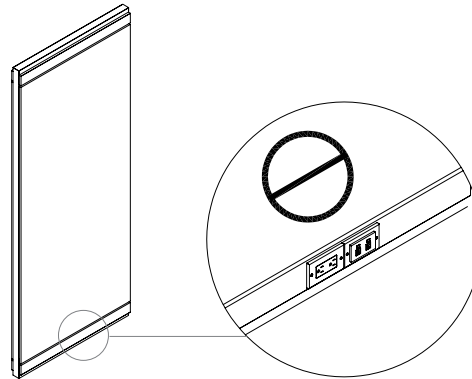

- Electrical or data **cannot** be mounted on the base fascia position

planning with electrics and communication

Base Height

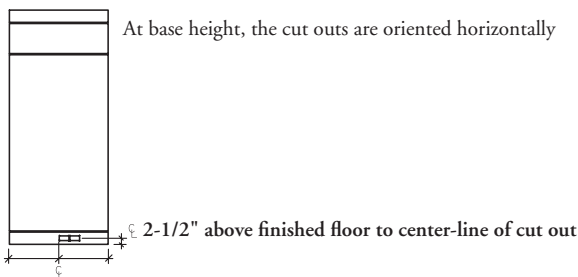

18" Height – Vertical Cut Out

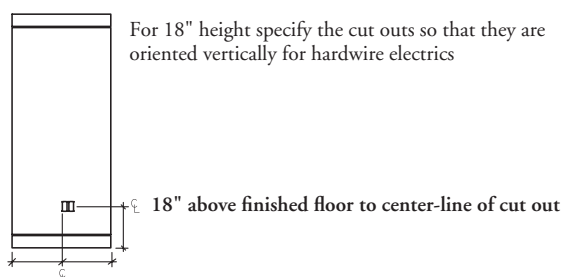

18" Height – Horizontal Cut Out

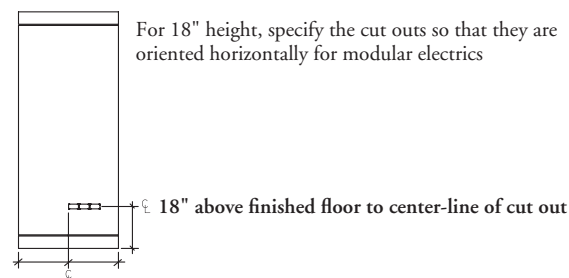



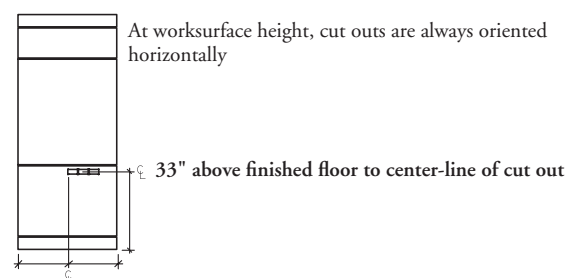

Worksurface Height



specifying fascias widths

The Fascia as shown below are offered in 1/8" increments in the widths shown.

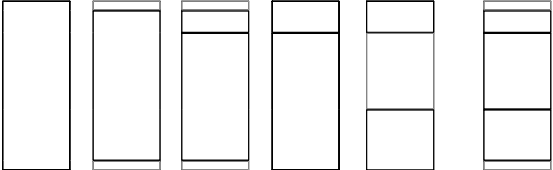
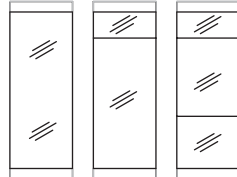
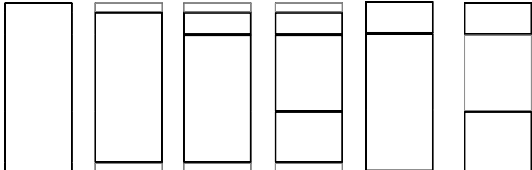
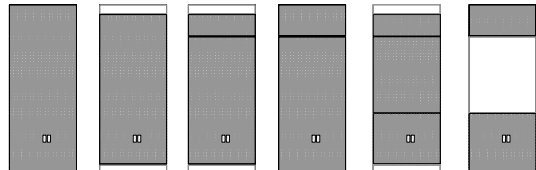
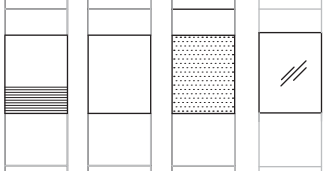
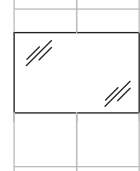
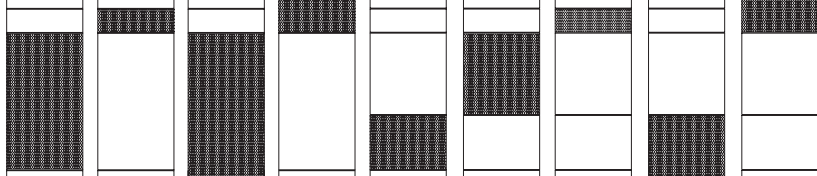
Fascia	Widths	Fascia	Widths
Base Fascia (FPB) 	12" – 48"	Ceiling Fascia (FPC) 	12" – 48"
Fabric Wrapped Base Fascia (FPRB) 	12" – 48"	Fabric Wrapped Ceiling Fascia (FPRC) 	12" – 48"
Solid Fascia – Monolithic, Full, Segmented, Working (FPM, FPF, FPS, FPSM, FPWM, FPW) 	12" – 48"	Glass Fascia – Single Center, Double (FPG) 	12" – 48"
Acoustic Fascia – Monolithic, Full, Segmented, Working (FPAM, FPAF, FPAS, FPAW, FPASM, FPAWM) 	12" – 48"	Fabric Wrapped Fascia – Monolithic, Full, Segmented, Working (FPRM, FPRF, FPRS, FPRSM, FPRW, FPRWM) 	12" – 48"
Smart Fascia – Accessory, Whiteboard, Tackable, Framed Backpainted Glass Markerboard (FPMA, FPMW, FPMT, FPMMF) 	30" – 48"	Framed Backpainted Glass – Markerboard Double Span (FDMMFD) 	48" – 96"
Micro Perforated Metal Acoustic Fascia - Segmented, Working (FPMP1, FPMP2, FPMP3, FPMP4, FPMP5, FPMP6, FPMP7, FPMP8, FPMP9) 	12" – 44"		

planning with fascia widths

The Fascia width affects all other products and should be chosen with this in mind.

Where possible, Fascia widths should be used to attain consistent Fascia core widths (i.e., 12", 18", 24", 30", 36", 40", 42" and 48").

Core Wall Widths

- Permits suspending of worksurfaces, mounted storage and accessories
- The 40", 42" and 48" (Barn Door only) Fascia widths match door widths
- Core Fascia widths accommodate reconfiguration better than 1/8" incremental widths

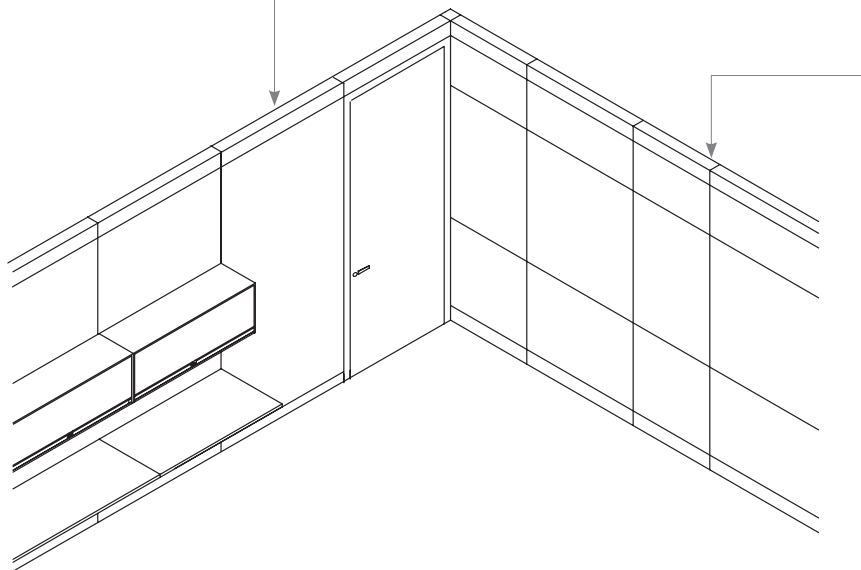

Planning with 1" incremental widths

- Fascias are offered in each 1/8" incremental widths between 12" to 48" for most Fascias
- 1" incremental width Fascias should **not** be used when hang-on components (worksurfaces, mounted storage and accessories) are required
- These widths do **not** permit suspending worksurfaces, mounted storage and accessories
- 1/8" incremental width Fascias do **not** match door widths and reconfigure less easily than core Fascia widths

Width variances can be accommodated by the Filler Panel (FPF) and Adjustable Wall End (FKE). For more information, see the Frame Kits section.

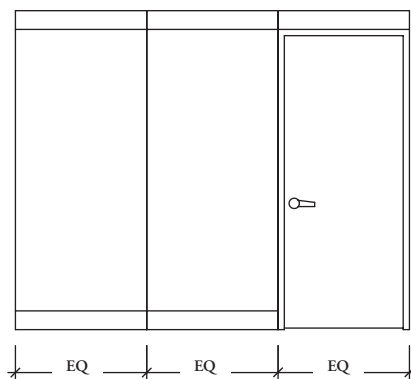

Limiting the number of Fascia width variations simplifies reconfiguration and planning

planning with acoustic & fabric wrapped fascias

Acoustic and Fabric Wrapped Fascias can be used in a variety of applications including training rooms, meeting rooms and private offices.

Acoustic fascias are not available for base, ceiling or W3, S2 fascias below 12" in height; use Fabric Wrapped fascias for these in these applications.

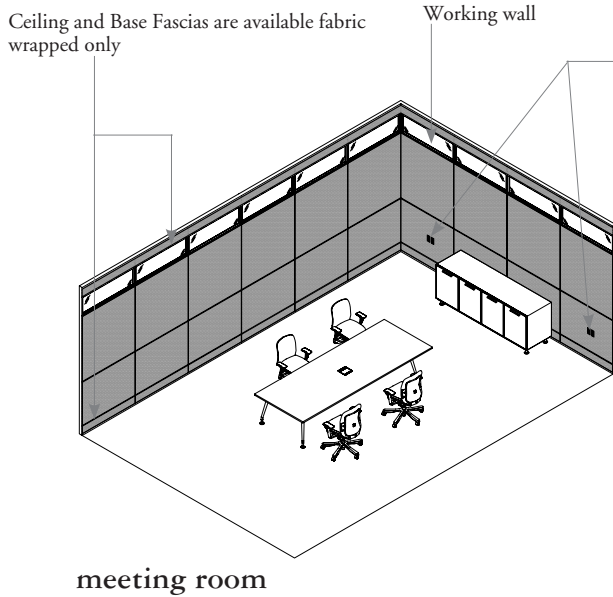
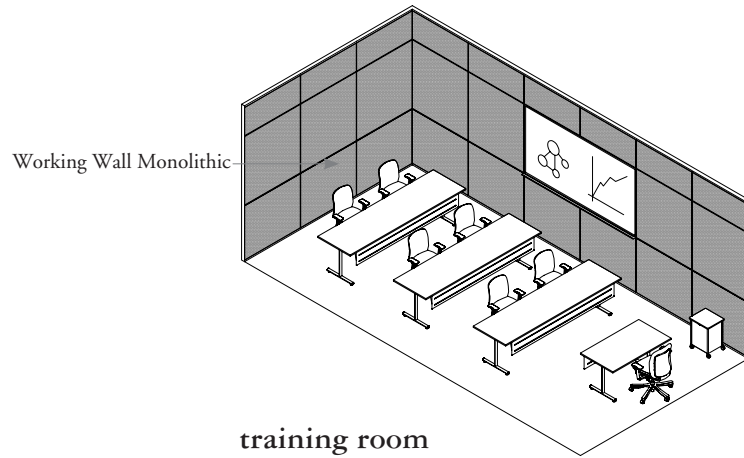

IMPORTANT: Fabric Wrapped Fascias should be used with Acoustic Fascias when power/communication cut outs are needed and Acoustic Fascias should have the same elevation specified on both sides

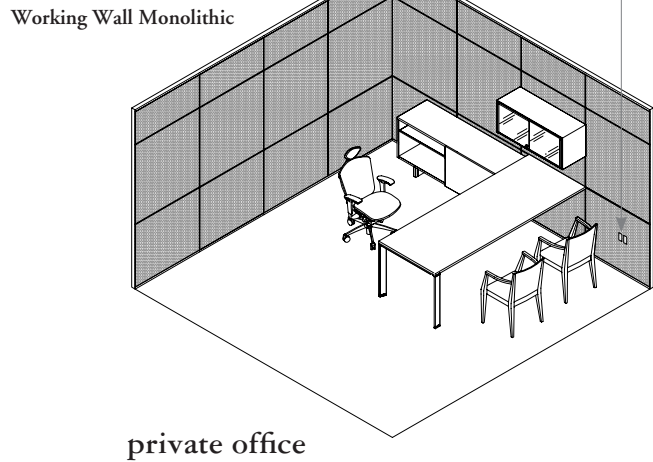

smart fascia basics

The Working Wall has the added ability of integrating Smart Fascias to provide a means of personalizing the office space while adding functionality to the vertical surface of the wall.

- Available only with Working Wall elevation at W2 location only
- Smart Fascias can be interchanged with any other Fascia of the same level and width

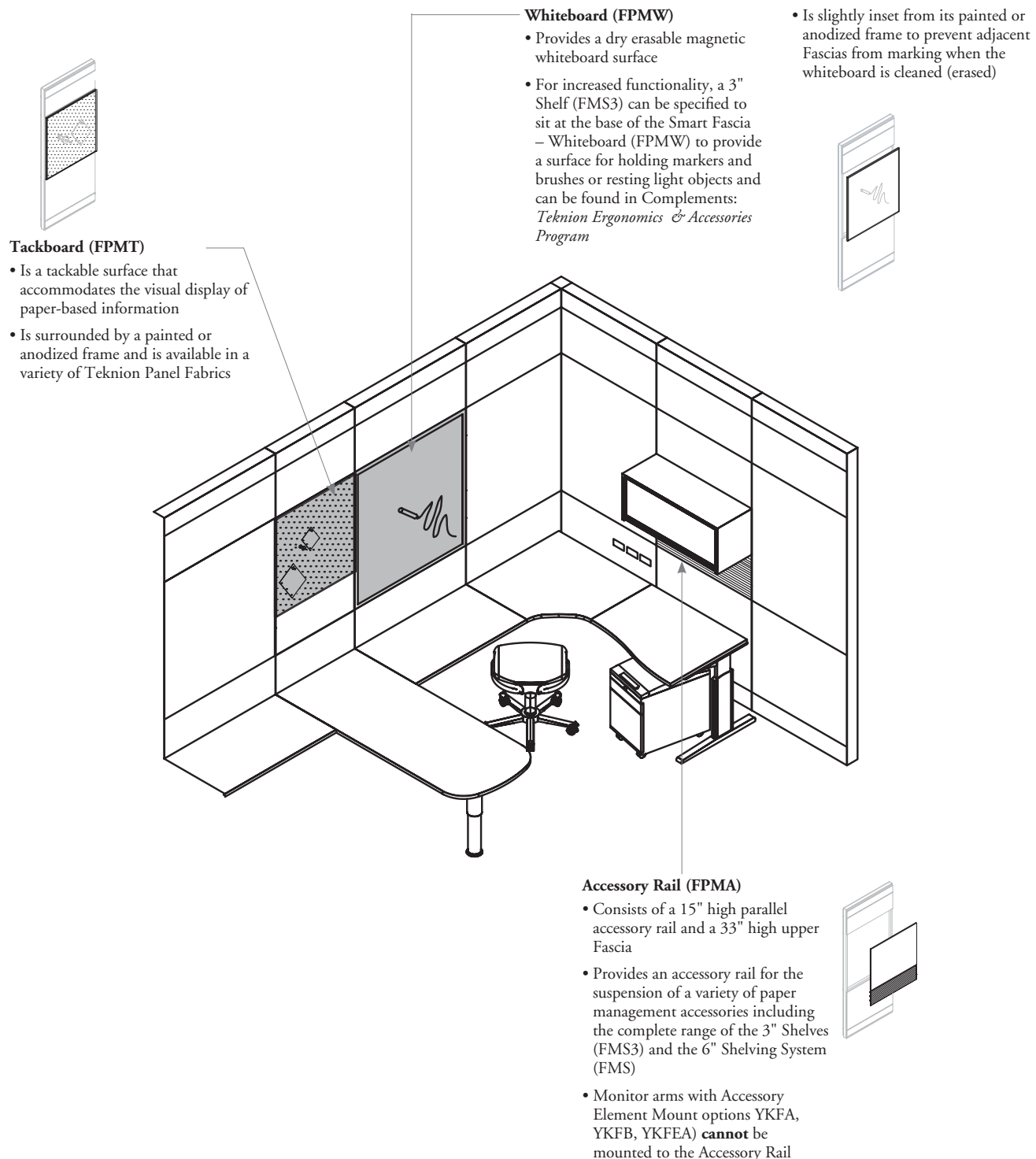

application guide

planning with smart fascias

Smart Fascias can be used in a variety of applications including private offices and meeting rooms.

All Smart Fascias can be used on both sides of applicable wall modules

Smart Fascia – Tackboard (FPMT)

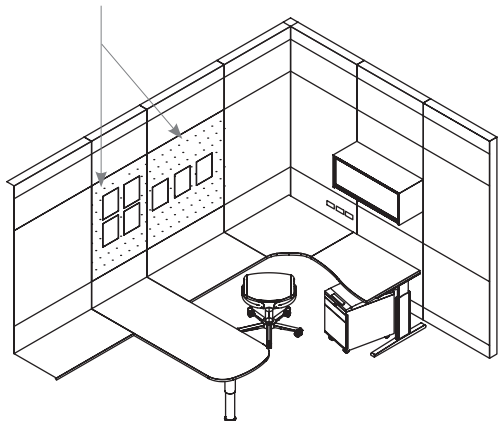

Tackboards used in a private office

Smart Fascia – Accessory (FPMA)

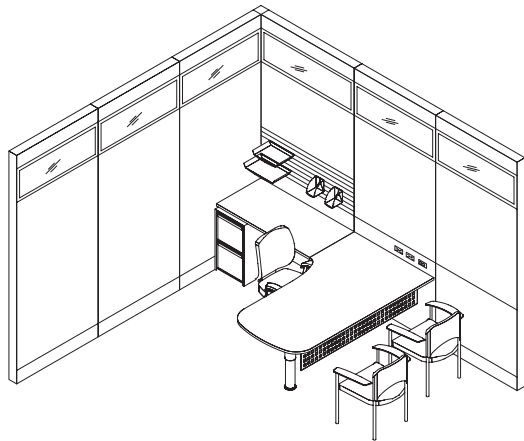

Accessory Rail used in a private office

Smart Fascia – Whiteboard (FPMW), Framed Backpainted Glass – Markerboard (FPMMF)

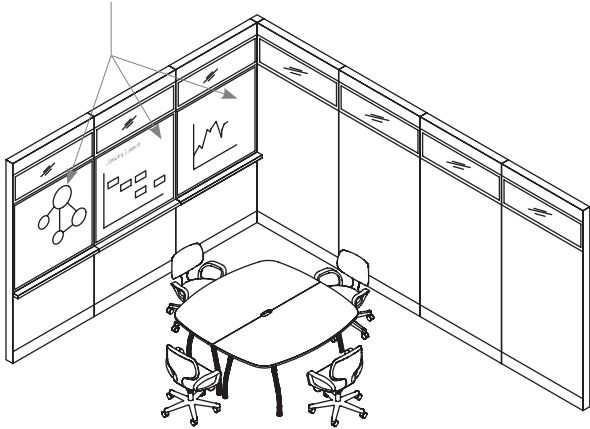

Whiteboards used in a meeting area

Framed Backpainted Glass – Markerboard Double Span (FDMMFD)

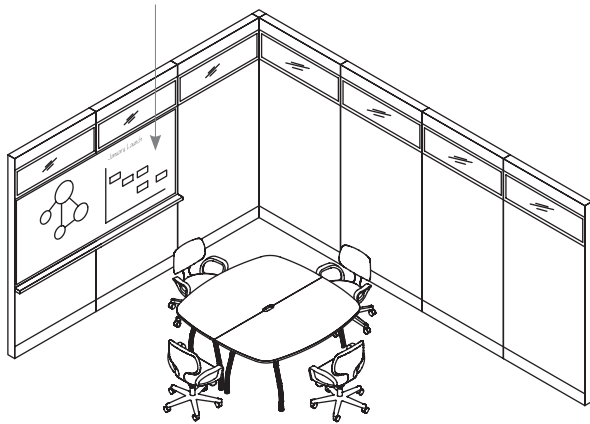

Whiteboards used in meeting area spanning across two panels.

filler panel basics

The Filler Panel (FPF) is used when an Altos wall surface needs to be cut away to fit the wall around the building structure, usually at the perimeter of the building.

Height	Ceiling Height Range
102" (8'-6")	86" to 102" (7'-2" to 8'-6")
108" (9'-0")	103" to 108" (8'-7" to 9'-0")
114" (9'-6")	109" to 114" (9'-1" to 9'-6")
120" (10'-0")	115" to 120" (9'-7" to 10'-0")

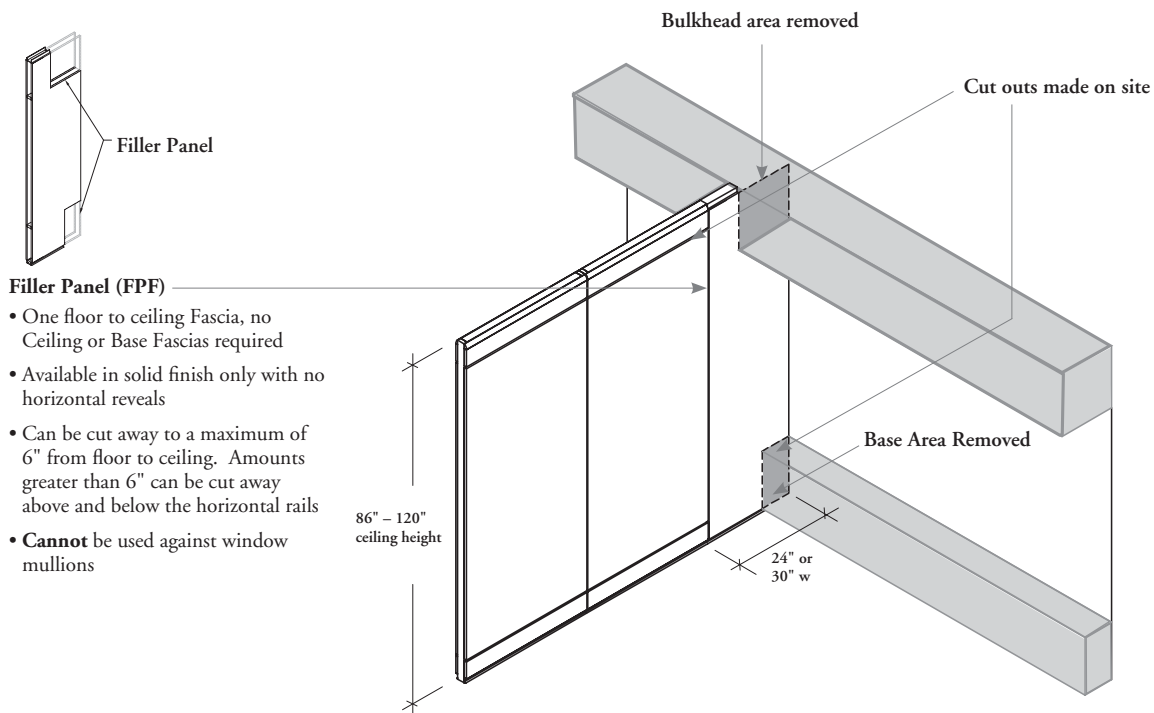

Filler Panel (FPF)

- One floor to ceiling Fascia, no Ceiling or Base Fascias required
- Available in solid finish only with no horizontal reveals
- Can be cut away to a maximum of 6" from floor to ceiling. Amounts greater than 6" can be cut away above and below the horizontal rails
- **Cannot** be used against window mullions

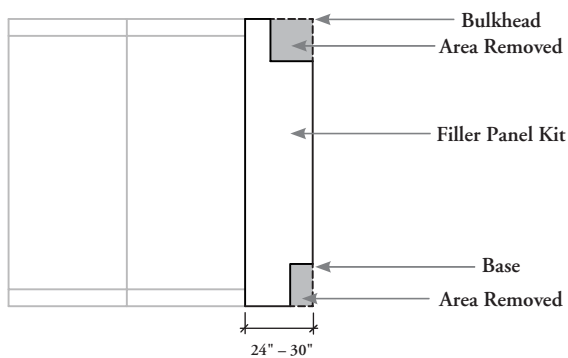

fascia finishes - portrait

The following finishes are available on Altos.

Solid Fascias

- Available 12" - 48" wide nominal in 1/8" increments
- Available in Fascia Laminates and Flintwood Veneers
- Available on the 4" or 6" base and ceiling fascias
- Accepts electrical boxes and switches
- Grain direction is vertical for Portrait fascias



The illustration above demonstrates the grain direction of Cathedral Flintwood finishes for fascias.

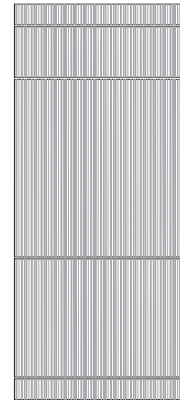

The illustration above demonstrates the grain direction of Standard Flintwood finishes for fascias.

Fabric Wrapped Fascias

- Available in 12" - 48" wide nominal in 1/8" increments
- Fabric Wrapped fascias provide a frameless fabric finish
- Available on the 4" base and ceiling fascias
- Accepts electrical boxes and switches
- Available in eight architectural fabrics
- Upholstery fabrics are not available
- Fabric direction is horizontal, architectural fabric direction is vertical

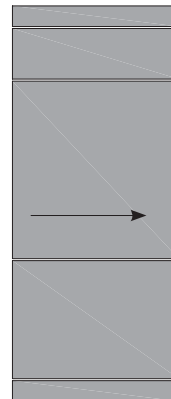

The illustration above demonstrates the Railroad fabric direction for Fabric Wrapped fascias.

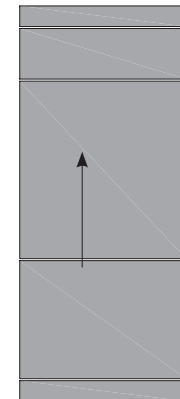

The illustration above demonstrates the Off-the-bolt fabric direction for Fabric Wrapped fascias.

Framed Backpainted Glass – Markerboard Fascias

- Available 24" - 48" wide nominal in 1/8" increments
- Available magnetic or non-magnetic
- Frame finishes include:
 - Clear Anodized
 - Painted
 - Very White
 - Graphite
 - Anthracite
 - Sepia Bronze
 - Burnished Bronze
 - Titanium Grey
 - Gilded Ash
 - Ebony
- Available only in W2 location on Working Wall and Cabinet Working Wall
- Electrical boxes and switches are not available on markerboard fascias
- Rare-earth magnets of grade N42 are recommended for use on glass markerboards

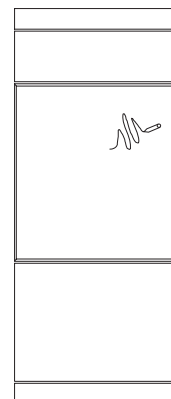

fascia finishes - portrait (continued)

Smart Fascias – Whiteboard

- Available 30" -48" wide in 1/8" increments
- Available magnetic
- Available only in W2 location on Working Wall
- Electrical boxes and switches are not available on whiteboard fascias
- Rare-earth magnets of grade N42 are recommended for use on glass whiteboards

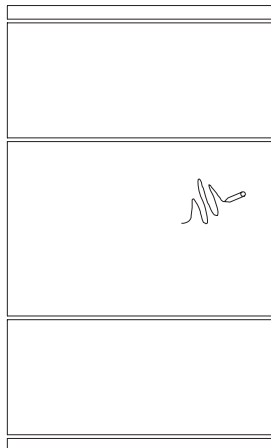

Acoustic Tackable Fascias

- High performance acoustic and tackable fabric fascia used within a space to absorb excess noise
- Available 48" high and 12" – 48" wide nominal in 1/8" increments
- Acoustic Tackable Fascias provide a frameless fabric finish
- Electrical boxes and switches are not available on Acoustic Tackable Fascias
- Available in select Panel and Architectural Fabrics
- Upholstery fabrics are not available
- Base and Ceiling Fascias are **not** available as Acoustic Tackable Fascias
- Fabric direction is horizontal, architectural fabric direction is vertical

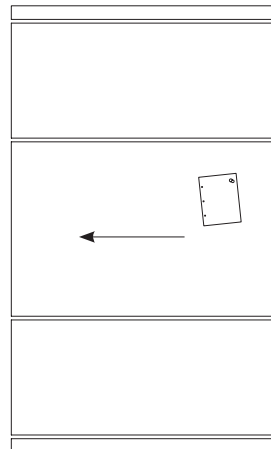

The illustration above demonstrates the Railroad fabric direction for Acoustic Tackable fascias.

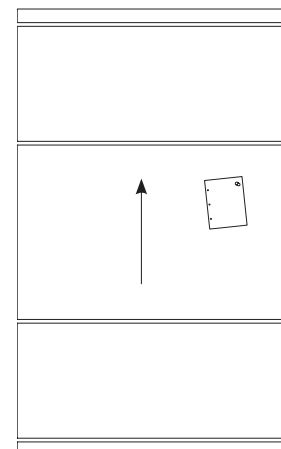

The illustration above demonstrates the Off-the-bolt fabric direction for Acoustic Tackable fascias.

Micro Perforated Metal Acoustic Fascias

- High performance acoustic and tackable metal fascia used within a space to absorb excess noise
- Available 12" - 44" wide nominal in 1" increments
- Available magnetic
- Electrical boxes and switches are not available on Micro Perforated fascias
- Acoustic Metal Micro Perforated Fascias that are planned back-to-back must be specified with Portrait Metal Backers (FPMB) to block sound transfer through wall.
- Available in painted finishes:

Foundation:	Mica:
- Crisp Grey	- Platinum
- Soft Gris	- Graphite
- Sand	- Anthracite
- Earth	- Sepia Bronze
- Slate	- Burnished Bronze
- Granite	- Titanium Grey
- Ebony	- Gilded Ash
	- Very White

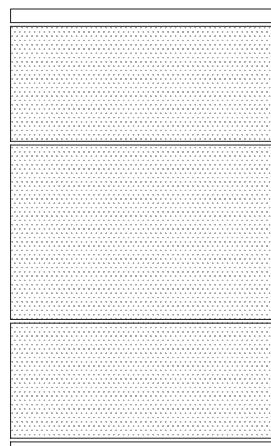

fascia finishes - portrait (continued)

Glass Fascias

- Available 6mm Single or Double glass
- Glass fascias are available in Square and Round Profile
- Available 6" - 12" high in 1" increments
- Clear tempered or laminated glass finishes available
- Available 12" - 48" wide nominal in 1/8" increments
- Frame Finishes include:
 - Clear Anodized Painted
 - Very White
 - Graphite
 - Anthracite
 - Sepia Bronze
 - Burnished Bronze
 - Titanium Grey
 - Gilded Ash
 - Ebony
- Electrical boxes and switches are not available on glass fascias

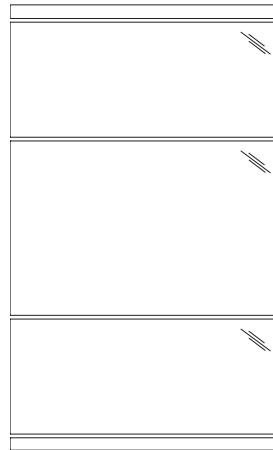

Working Wall elevation shown

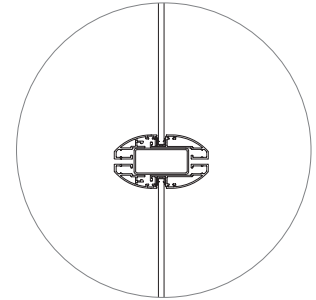

Section of round profile glass fascia

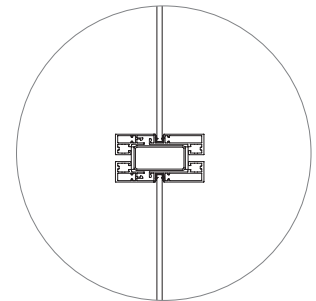

Section of square profile glass fascia

glass fascias

- When clear glass is specified on Double Glass Fascias, both panes will be clear
- When Frosted Glass is specified on Double Glass Fascias only one pane will be frosted; the other pane will be clear
- Single Glass Fascia is centered in frame
- Specialty glass is only available on Glass Fascia – Single Centered
- Available in Clear and Frost

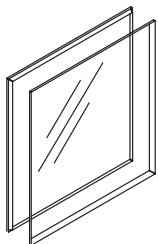

Standard – Clear

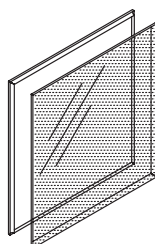

Standard – Frost

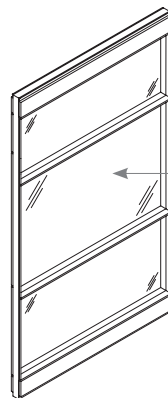

Working Wall Elevation

Level W2
(48" High)

fascia finishes - portrait (continued)





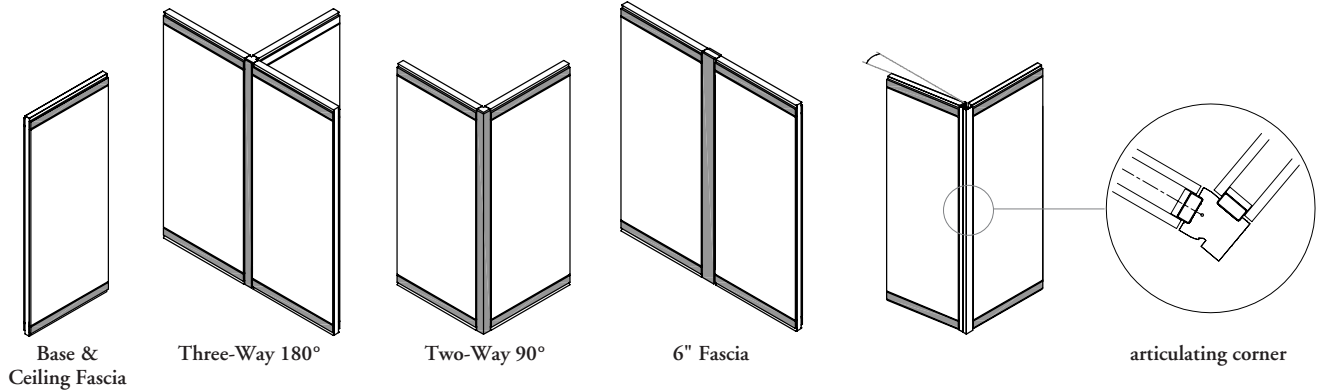

The following finishes are available on Altos.

aluminum finish fascias

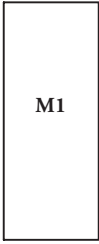
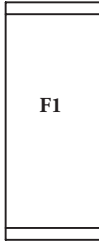
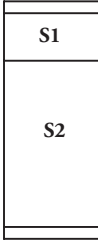
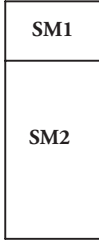
- Available on the 4" base and ceiling
- Available on most corner straight and articulating connectors
- Coordinates with glass store front options

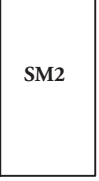
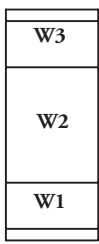
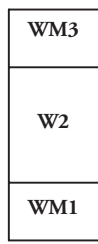

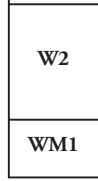
fascia finishes - portrait (continued)

	Monolithic	Full	Segmented				Working Wall					Ceiling Fascia	Base Fascia
													
	M1	F1	S1	S2	SM1	SM2	W1	W2	W3	WM1	WM3		
Solid	✓	✓	✓	✓	✓	✓	✓	✓	✓	✓	✓	✓	✓
Acoustic	✓	✓	✓	✓	✓	✓	✓	✓	✓	✓	✓		
Acoustic Tackable	✓	✓	✓	✓	✓	✓	✓	✓	✓	✓	✓		
Fabric Wrapped	✓	✓	✓	✓	✓	✓	✓	✓	✓	✓	✓	✓	✓
Glass *1		✓	✓	✓			✓	✓	✓				
Framed Backpainted Glass Markerboard *2								✓ *2					
Smart Fascia Accessory								✓					
Smart Fascia Whiteboard								✓					
Smart Fascia Tackable								✓					
Sheet Metal Backer			✓	✓	✓	✓	✓	✓	✓	✓	✓		
Micro Perforated Metal			✓	✓	✓	✓	✓	✓	✓	✓	✓		
Aluminum												✓	✓

*1 Single Centered, Round Corner and Square Corner available. Also Double Centered, Round Corner and Square Corner available.

*2 Single Span and Double Span available

portrait –
door packages

portrait – door packages

DOOR OVERVIEW	73
HINGED DOOR BASICS	74
PIVOT DOOR BASICS	75
SINGLE BARN DOOR BASICS	76
DOUBLE BARN DOOR BASICS	77
DOOR WIDTHS	78
DOOR HARDWARE LOCATIONS	80
TRANSOM HEIGHT	81
BUILDING UP A COMPLETE DOOR MODULE	82
PLANNING WITH DOORS	84
PLANNING WITH SINGLE BARN DOORS	85
PLANNING WITH DOUBLE BARN DOORS	86

door overview

For typical openings, Altos offers a variety of doors that meet a range of privacy and functional needs – the three basic types are: Hinged, Pivot and Barn.

- Solid doors are 1-3/4" thick
- Glass doors are 10mm thick (3/8" nominal thickness)
- Swing doors and frames specified separately
- Barn door jambs and rails specified separately
- Low profile door styles bring the aesthetics of Optos doors into the Altos product line
- Consideration for ADA compliant locking hardware for doors needs to be determined early in the project cycle. Teknion offers a custom special solution that complies with ADA requirements, subject to local approvals.
- Check local regulatory codes for minimum clear height allowed for door openings

building up door modules

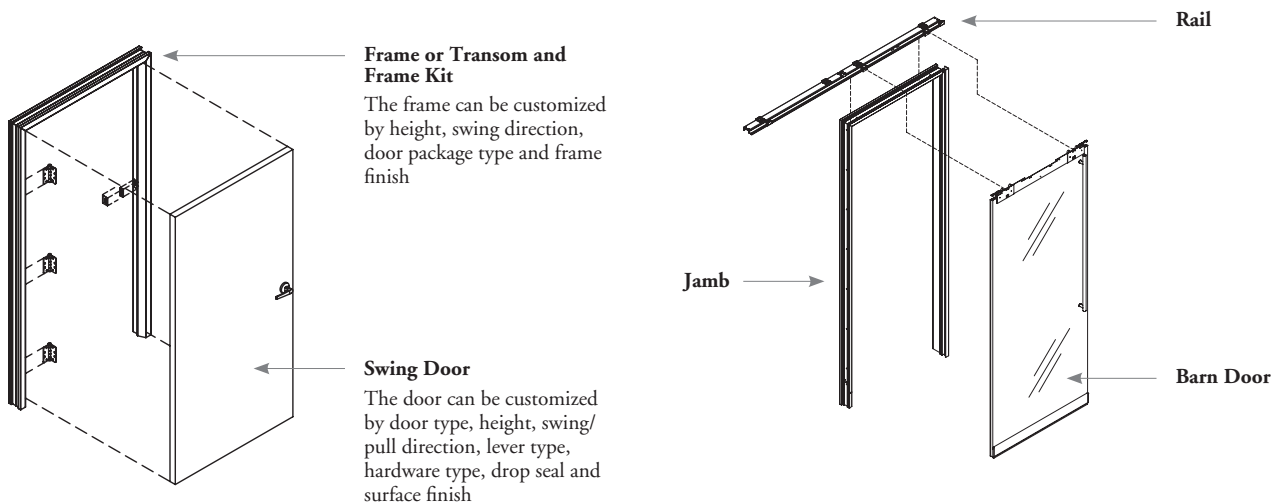

lever types for Swing Doors:

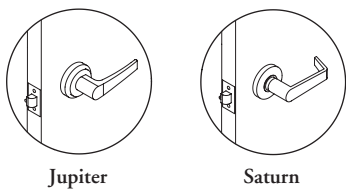

handle types for Barn Doors:

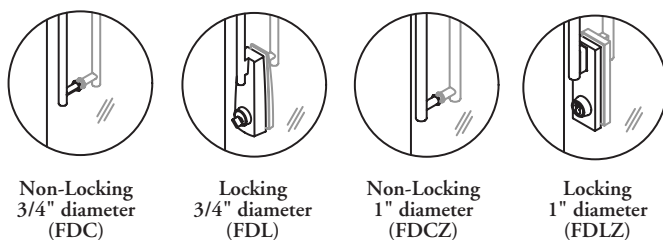

hardware types:

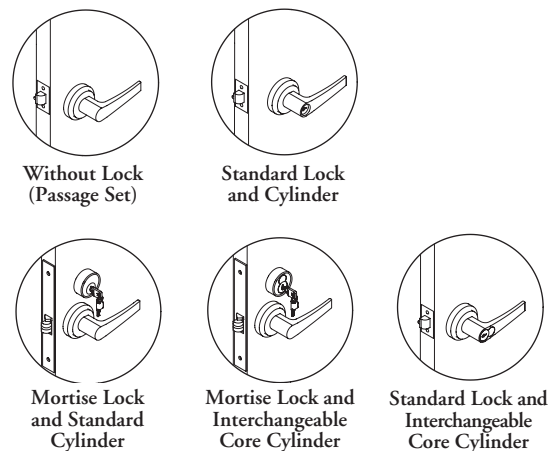

- Doors specified with "Standard Cylinder" are keyed randomly (two keys provided per door)
- Doors specified with "Interchangeable Core Cylinder" are keyed randomly (two keys provided per door) yet can be removed by a universal control key (one key provided per order)
- After installations, customers may choose to relocate or replace interchangeable core cylinders to suit their security needs

hinged door basics

Hinged doors create an opening with a 180°.

A drop seal is an option to minimize sound leakage at the bottom of the solid doors (up to 0.5" gap under door).

Hinged Door (FDH/FPDH)

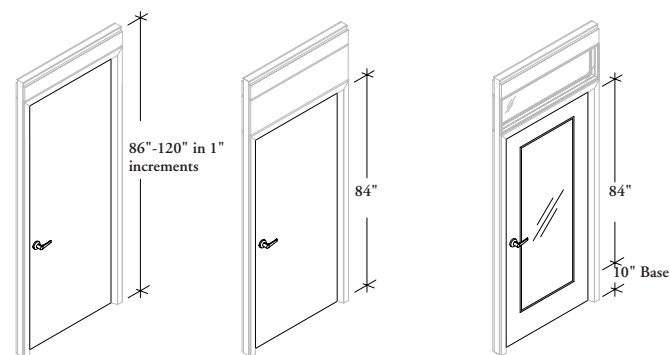

Full-Height
Creates a 180° swing

84" high (with Solid Transom)

- 84" segmented requires a transom measuring between 6" & 30" for ceiling heights between 86" & 120" in 1" increments
- Transom can be Solid or Glass

84" high (with Glass Insert and Glass Transom)

Available with clear or frost glass insert options for privacy aesthetic variation

Hinged Glass Door (FDJ/FPDJ)

An optional 10" high stainless steel kickplate may also be specified

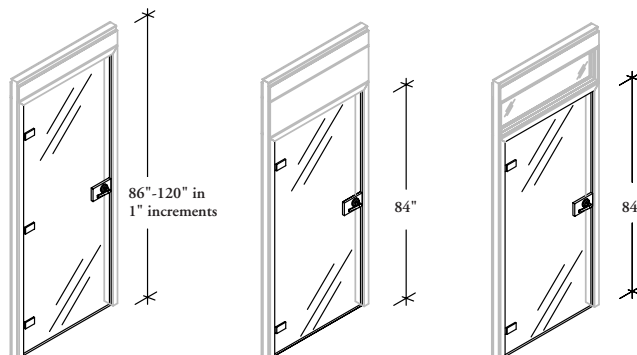

Full-Height

84" high (with Solid Transom)

84" high (with glass insert and Glass Transom)

- Door will be ceiling height minus ceiling fascia height
- Transom can be Solid or Glass
- Glass is Clear or Frost and has a 3/8" nominal thickness

Hinged Double Door (FDD/FPDD)

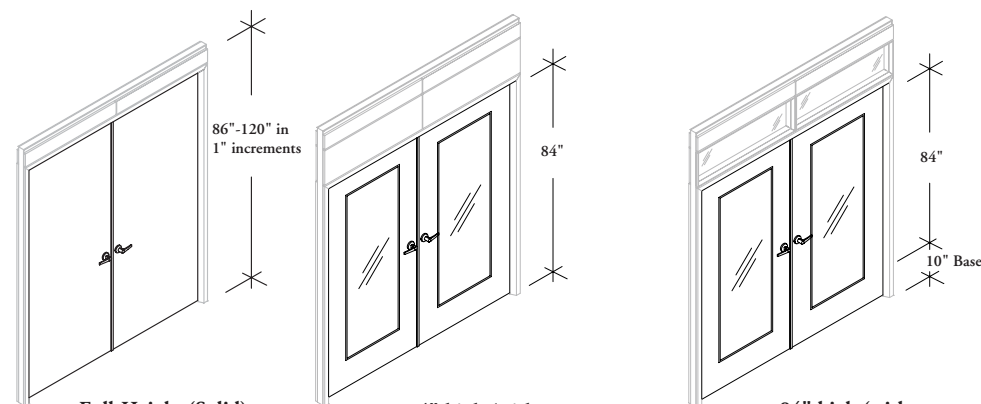

Full-Height (Solid)

84" high (with glass insert and Solid Transom)

84" high (with glass insert and Glass Transom)

- 84" segmented requires a transom measuring between 6" and 32" for ceiling heights between 86" and 120" in 1" increments
- Available with Clear or Frost glass insert options for privacy aesthetic variation – Transom can be Solid or Glass

Hinged Glass Double Door (FDE/FPDE)

An optional 10" high stainless steel kickplate may also be specified

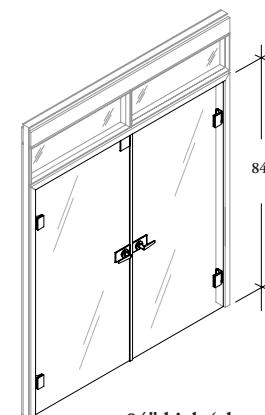

84" high (glass with glass transom)

84" Segmented requires a transom measuring between 6" and 32" ceiling heights between 86" and 120" in 1" increments

The Solid Pivot Door uses pivot hardware to attain a 90° swing. The Glass Pivot Door is a full height door that pivots open 180° with an optional adjustable door closer/door stay. It has enhanced acoustic performance offered by its continuous Frame Seal.

Framed Glass Pivot Door (FDPZ/FPDPZ)

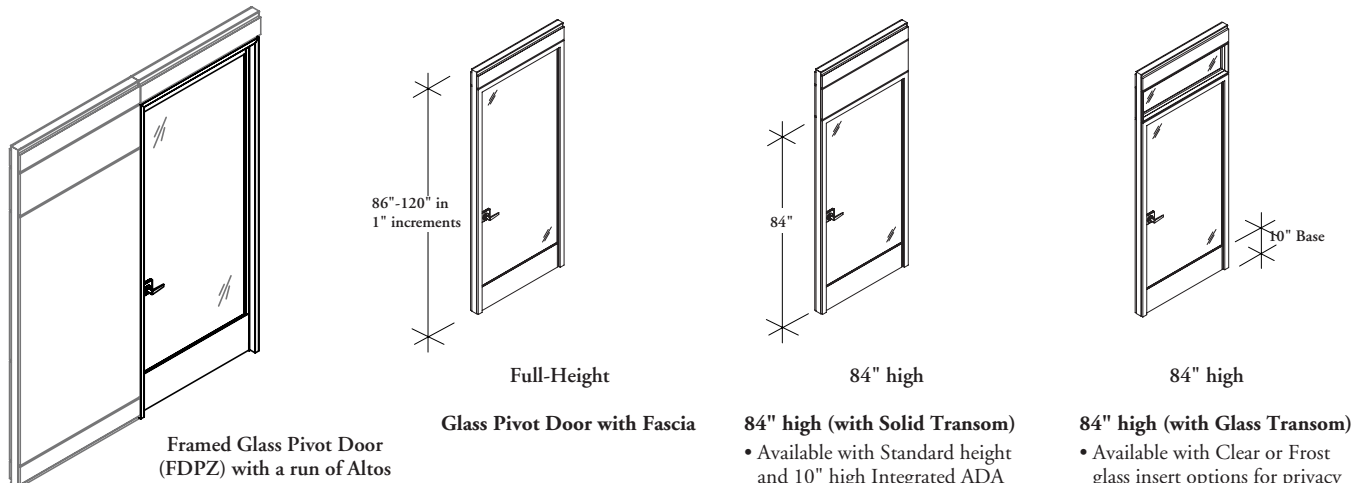

- Available with 4" or 6" Ceiling Fascia or for Segmented Height with transom
- Glass is available 10mm thick, Tempered or Tempered-Laminated
- Two lever types available as standard: Jupiter and Saturn
- Frame finishes include Anodized and Painted finishes

84" high (with Solid Transom)

- Available with Standard height and 10" high Integrated ADA Aluminum Kickplate

- Available with or without standard lock and interchangeable core cylinder or no lock

84" high (with Glass Transom)

- Available with Clear or Frost glass insert options for privacy and aesthetic variation

single barn door basics

The Single Barn Door creates a sliding door by mounting to the outside face of wall modules.

- Please check local code requirements, as in some jurisdictions, the use of the Barn Door is limited to room occupancies of 10 people maximum
- Adds 1" to wall module depth
- Locks **cannot** be retrofitted on Barn Doors
- Segmented height doors can only be planned adjacent to segmented or working wall elevations
- Monolithic elevations **cannot** be used adjacent to segmented or full-height barn doors
- The Barn Door nominal AFF is constant for hardware types 3 and 4
- Solid and Solid with Insert **cannot** be used with 4" base and ceiling fascias
- 48" wide Glass Door is **not** available in ceiling heights greater than 108"
- Consideration for ADA compliant locking hardware for doors needs to be determined early in the project cycle. Teknion offers a custom special solution that complies with ADA requirements, subject to local approvals

Glass and Solid Barn Door (FDC, FDS, FDI)

Segmented Height Glass Door

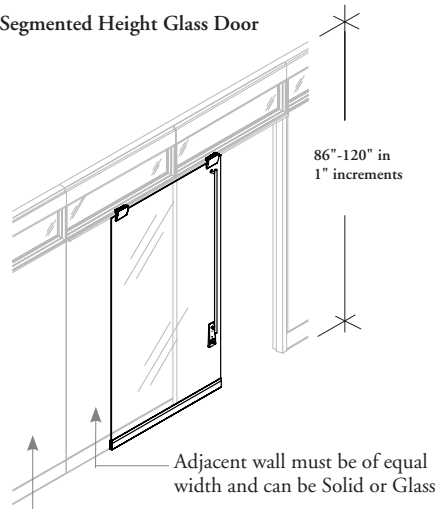

- May be mounted on inside or outside of wall module unless specified with lock, then it must be on the outside
- Keyed lock is on the outside and thumb turn on the inside

Solid Full-Height

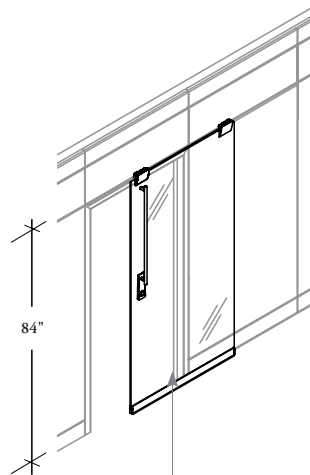
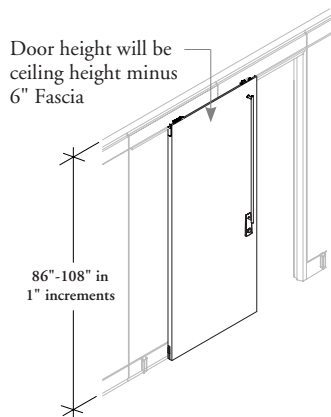

Slide direction determines left or right handedness (Right-Handed shown)

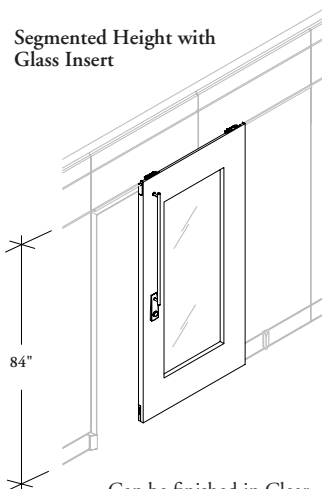

Can be finished in Clear or Frost Glass and can be adjacent to Solid and Glass Fascias

Glass Door Full-Height

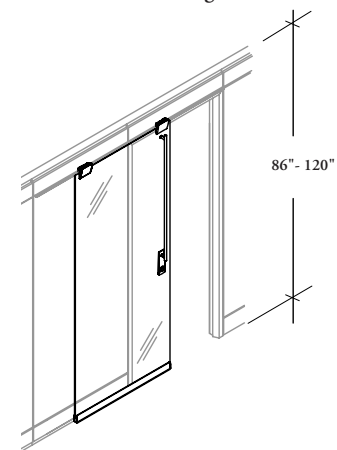

Glass Barn Door Low Profile (FDCZ)

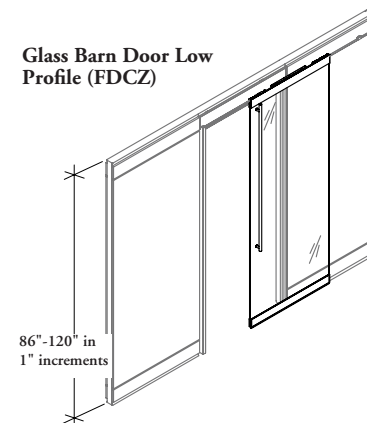

- Available in widths of 40" and 42" only
- 4" ceiling fascia height
- Door slides can be left or right and can be interior or exterior
- Available with or without standard lock and interchangeable core cylinder
- Glass is available in tempered and tempered Laminate
- Can be specified with or without soft close mechanism. Trolley and Base Cover finish include Anodized and Paint
- Should **not** be used with adjacent Fabric Fascias

double barn door basics

The Double Barn Door creates sliding doors by mounting to the inside or the outside face of wall modules.

- Please check the local code requirements, as in some jurisdictions, the use of the Barn Door is limited to room occupancies of 10 people maximum
- Adds 1" to wall module depth
- Locks **cannot** be retrofitted on Barn Doors
- The Barn Door nominal AFF is constant for hardware types 3 and 4
- Glass Barn Doors only
- Full-height format only (**not** available in segmented height)
- Only available for use with 6" ceiling fascias

Double Barn Door (FDL)

- Adjacent module width is determined by the door width and **cannot** be a monolithic elevation
- For 72" wide doors, adjacent modules must be 29"
- For 80" wide doors, adjacent modules must be 33"

Doors may be mounted on inside or outside of wall module unless specified with lock, then they must be on the outside

- Locking or non-locking is available
- Door locks at right hand door or inside of left hand door
- When lock option is specified, left hand door (from the outside) includes a painted cover plate to match right hand door

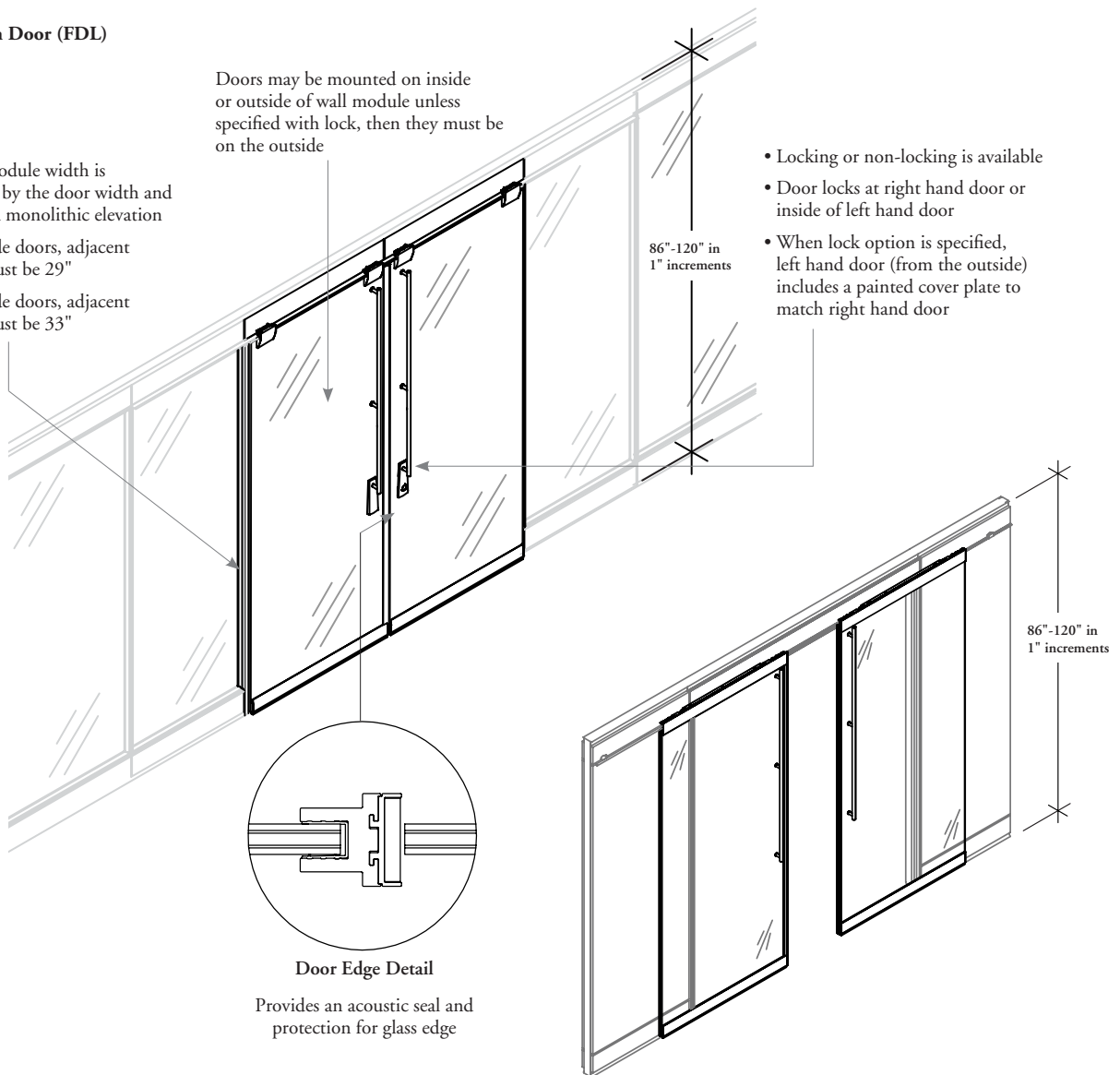

Double Glass Barn Door Low Profile (FDLZ)

- 72" wide only
- Can only be ordered with 4" ceiling fascia configuration
- Available with or without standard lock an interchangeable core cylinder
- Available in Tempered or Tempered-Laminated glass
- Base Cover and Trolley finish include Anodized and Painted finishes
- Should **not** be used with adjacent Fabric Fascias

door widths

Door module (frame and door) widths and door clearances for all doors including frame are shown below.

Single Hinged, Glass and Pivot Doors and Door Frame Package

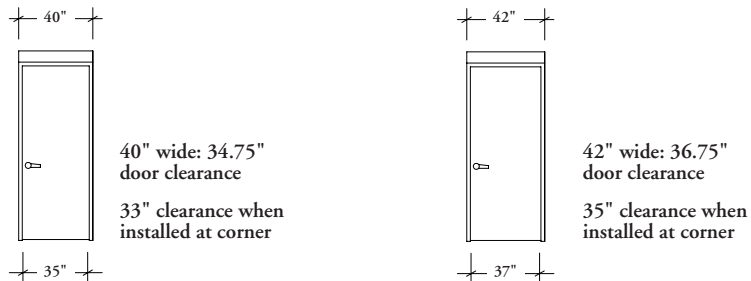

Double Hinged Door and Double Door Transom & Frame Package, Hinged Glass Double Door and Glass Double Door Transom & Frame Package Segmented

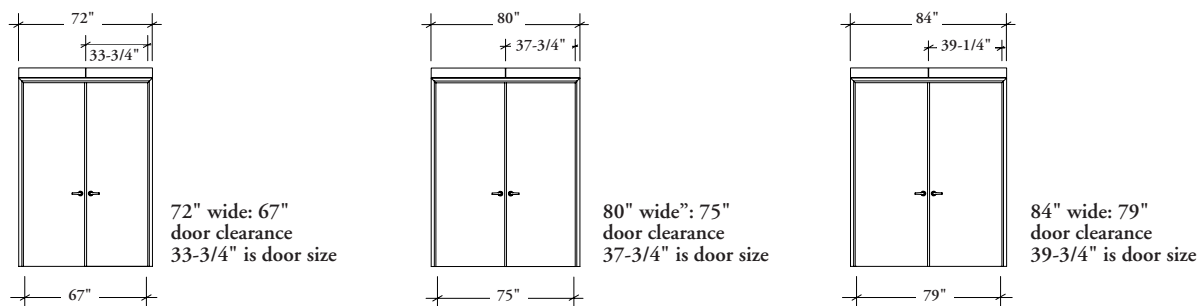

Framed Glass Pivot Door

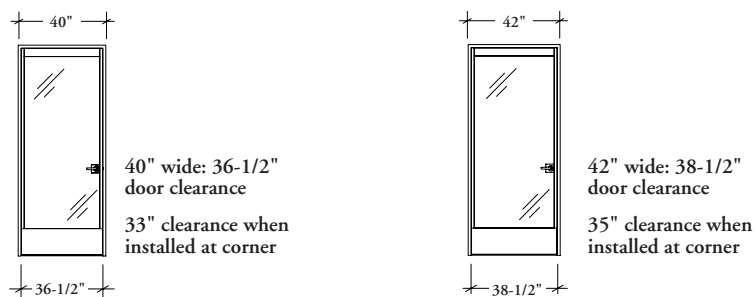

door widths (continued)

Single Glass Barn Door and Solid Barn Door Transom with Rail and Jamb Package

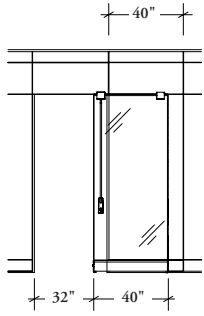

40" wide: 32" door clearance

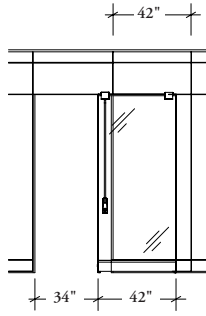

42" wide: 34" door clearance

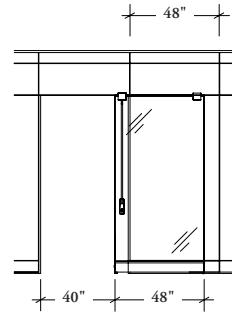

48" wide: 40" door clearance

Single Glass Barn Door Low Profile with Rail and Jamb Package

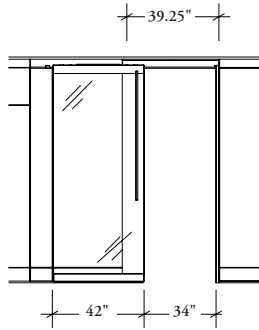
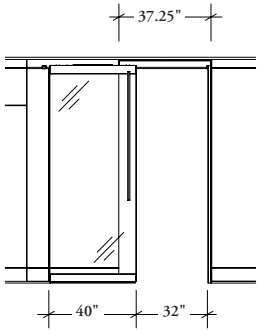

Double Glass and Solid Barn Door with Rail and Jamb Package

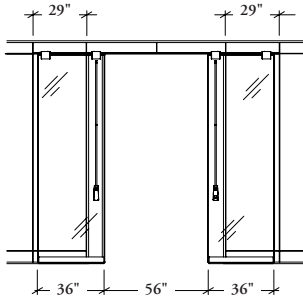

36" wide: 56" door clearance

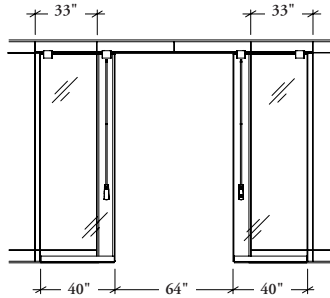

40" wide: 64" door clearance

Double Glass Barn Door - Low Profile with Rail and Jamb Package

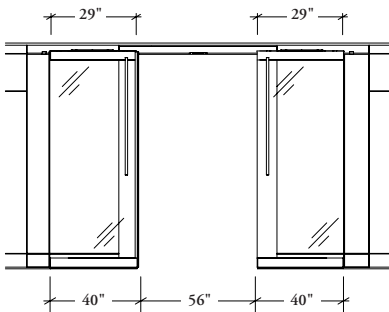

door hardware locations

The hardware locations for glass barn door is constant.

AFF Constant

Distant from finished floor to bottom of handle is a constant regardless of the ceiling height.

Type 3 No Lock, Handle AFF constant

Type 4 Standard Lock and IC Cylinder, Handle AFF constant

Ceiling Height	Handle Position AFF
86 - 120	39-3/4

Glass Barn Door Low Profile (FDCZ)

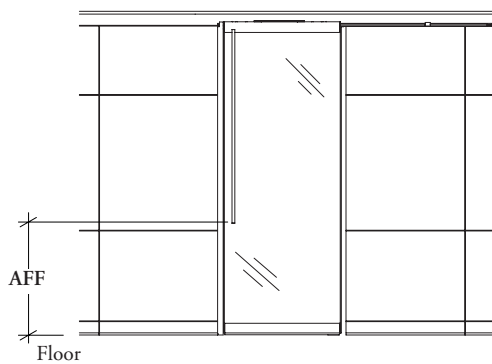

Non Locking

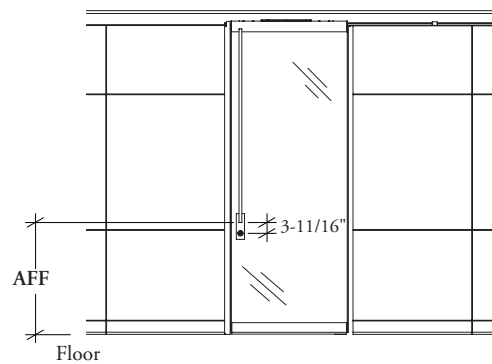

Locking

Double Glass Barn Door – Low Profile (FDLZ)

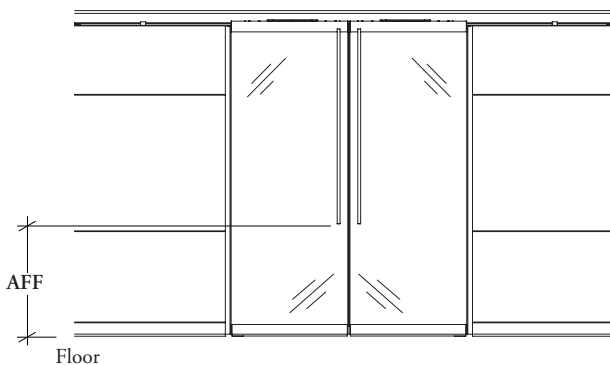

Non Locking

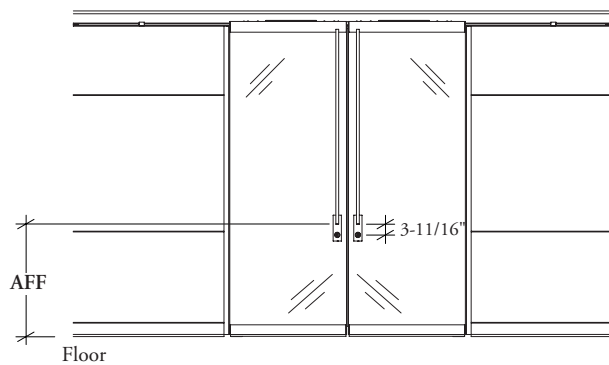

Locking

Nominal AFF is constant for hardware types 3 and 4

transom height

The height of the transom above 84" high doors varies in relation to the ceiling height.

- To determine the correct height of Fascia for the transom above a 84" high door, use Chart 1: Transom Height
- To determine the correct width of Fascias for the Transom and Ceiling Fascia above the Hinged Double Doors (FDE and FDD) and Barn Doors (FDS/FDC) use Chart 2: Double Door/Barn Door Transom Fascia and Ceiling Fascia width chart
- All structural members Vertical Post Packages (FKV), Horizontal Rail Packages (FPKH), Ceiling Channel (FKN), etc) for doors are specified separately in the appropriate sections. See Frame Kits For more information

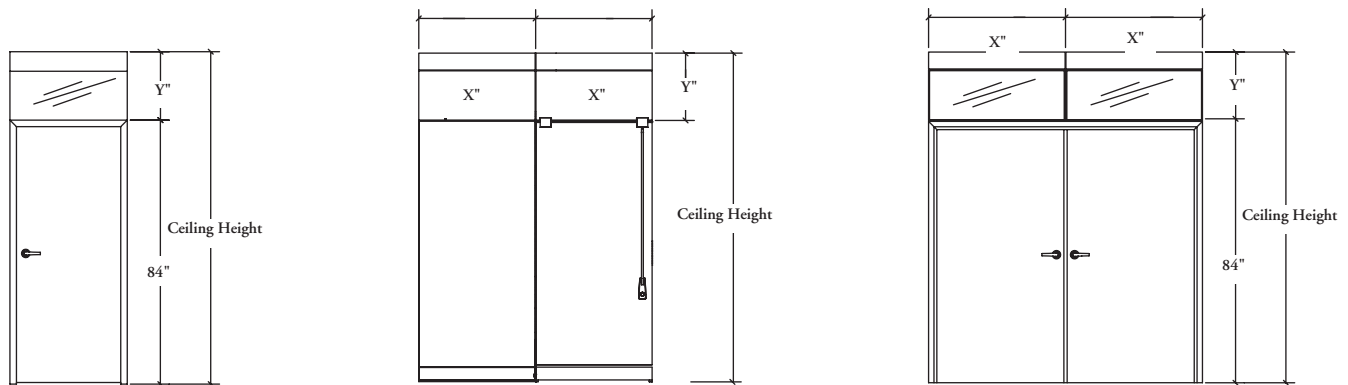

Chart 1:

Transom Height Chart for 4" Ceiling Fascia

Ceiling Height (")	Transom Height Y"
96	8
97	9
98	10
99	11
100	12
101	13
102	14
103	15
104	16
105	17
106	18
107	19
108	20
109	21
110	22
111	23
112	24
113	25
114	26
115	27
116	28
117	29
118	30
119	31
120	32

Transom Height Chart for 6" Ceiling Fascia

Ceiling Height (")	Transom Height Y"
96	6
97	7
98	8
99	9
100	10
101	11
102	12
103	13
104	14
105	15
106	16
107	17
108	18
109	19
110	20
111	21
112	22
113	23
114	24
115	25
116	26
117	27
118	28
119	29
120	30

Chart 2:

Double Door/Barn Door Transom Fascia and Ceiling Fascia Width Chart

Double Door Width (")	Fascia Width X"
72	36
80	40
84	42

building up a complete door module

Several frame packages are available for door packages. See price pages for details of these products.

- It is not recommended to install a door adjacent to a Wall End (FKE), Wall Start (FKW/FPKW) or Filler Panel (FPF)
- If Fascias are required to complete assembly they must be specified separately

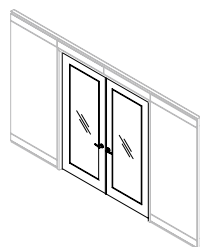

Full Height Hinged Double Door (FDD/FPDD)

- Required Double Door Frame – Full Height (FKTF/FPFDS)
- Used with 4 Ceiling Fascias (FPC) - 2 per side

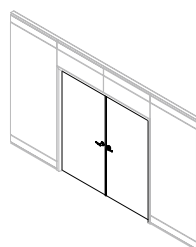

Segmented Double Door (FDD/FPDD)

- Required Double Door Transom & Frame – Segmented Height (FKTS)
- Used with 4 Ceiling Fascias (FPC) - 2 per side
- 4 Solid Fascias – Segmented (FPS2) or 2 Glass Fascia – Double (FPGD) or 2 Glass Fascia – Single Center (FPGC)

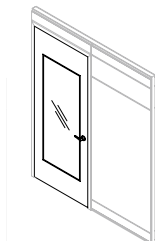

Full Height Hinged Door (FDH/FPDH) or Glass Door (FDJ/FPDJ)

- Required Door Frame Kit (FKD/FPFJS/FPFHS)
- Used with 2 Ceiling Fascias (FPC) - 1 per side



Segmented Hinged Door (FDH/FPDH) or Glass Door (FDJ/FPDJ)

- Required Door Frame Kit (FKD)
- Used with 2 Ceiling Fascias (FPC) - 1 per side
- 2 Solid Fascias – Segmented (FPS2) or 1 Glass Fascia – Double (FPGD) or 1 Glass Fascia – Single Center (FPGC)



Full Height Glass Barn Door (FDC)

- Required for the Portrait Barn Door Rail Kit for Full-Height Door (FPBFR) and Portrait Barn Door Jamb Kit for Full-Height Glass Door (FPBGFJ)
- Used with 2 Ceiling Fascias (FPC) - 1 per side

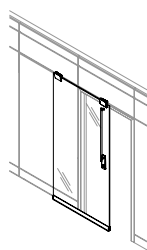

Segmented Glass Barn Door (FDC)

- Required for use with Portrait Barn Door Rail Kit for Segmented-Height Door (FPBSR) and Portrait Barn Door Jamb Kit for Segmented-Height Glass Door (FPBGSJ)
- Used with 2 Ceiling Fascias (FPC) - 1 per side
- 2 Solid Fascias – Segmented (FPS2) or 1 Glass Fascia – Double (FPGD) or 1 Glass Fascia – Single Center (FPGC)



Full Height Solid Barn Door (FDS/FDI)

- Required for Portrait Barn Door Rail Kit for Full-Height Door (FPBFR) and Portrait Barn Door Jamb Kit for Full-Height Solid Door (FPBSFJ)
- Used with 2 Ceiling Fascias (FPC) - 1 per side

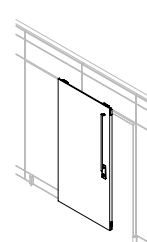

Segmented Solid Barn Door (FDS/FDI)

- Required for use with Portrait Barn Door Rail Kit for Segmented-Height Door (FPBSR) and Portrait Barn Door Jamb Kit for Segmented-Height Solid Door (FPBSJ)
- Used with 2 Ceiling Fascias (FPC) - 1 per side
- 2 Solid Fascias – Segmented (FPS2) or 1 Glass Fascia – Double (FPGD) or 1 Glass Fascia – Single Center (FPGC)

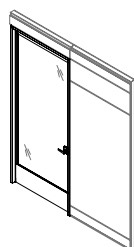

Full Height Framed Glass Pivot Door (FDPZ/FPDPZ)

- Required for use with Glass Pivot Door Solid Frame Kit (FKPSZ/FPFPS)
- Used with 2 Ceiling Fascias (FPC) - 1 per side

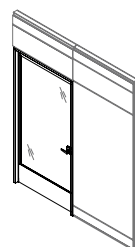

Segmented Framed Glass Pivot Door (FDPZ/FPDPZ)

- Required for use with Glass Pivot Door Solid Frame Kit (FKPSZ)
- Used with 2 Ceiling Fascias (FPC) - 1 per side
- 2 Solid Fascias – Segmented (FPS2) or 1 Glass Fascia – Double (FPGD) or 1 Glass Fascia – Single Center (FPGC)

building up a complete door module (continued)

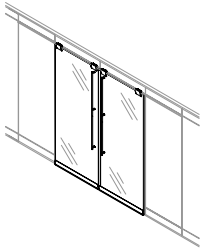

- Full Height Double Glass Barn Doors (FDL)**
- Required for use with Portrait Double Barn Door Rail Kit for Full-Height Door (FPLGFR) and Portrait Double Barn Door Jamb Kit for Full-Height Glass Door (FPLGFJ)
 - Used with 4 Ceiling Fascias (FPC) - 2 per side

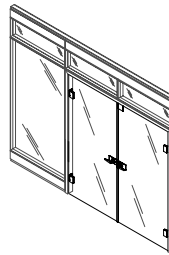

- Segmented Hinged Glass Double Door (FDE/FPDE)**
- Required for use with Hinged Glass Double Door Transom & Frame Package – Segmented Height (FKTES)
 - Used with 4 Ceiling Fascias (FPC) - 2 per side
 - 4 Solid Fascias – Segmented (FPS2) or 2 Glass Fascia – Double (FPGD) or 2 Glass Fascia – Single Center (FPGC)

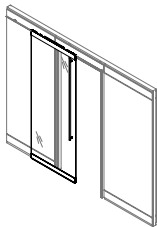

- Full Height Glass Barn Door (FDCZ)**
- Required for use with Portrait Barn Door Rail Kit for Full Height Door – Low Profile (FPUGFR) and Portrait Barn Door Jamb Kit for Full Height Glass Door – Low Profile (FPUGFJ)
 - Used with 2 Ceiling Fascias (FPC) – 1 per side

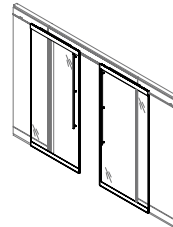

- Full Height Double Glass Barn Door (FDLZ)**
- Required for use with Portrait Double Barn Door Rail Kit for Full-Height Door – Low Profile (FPVGFR) and Portrait Double Barn Door Jamb Kit for Full-Height Glass Door – Low Profile (FPVGFJ)
 - Used with 4 Ceiling Fascias (FPC) - 2 per side

planning with doors

The following rules should be considered when planning with Altos doors.

- The door swing is identified as right or left according to the location of the hinges
- Door swing orientation must be specified for the Hinged, Hinged Glass, Pivot and Hinged Double door

Pivot and Hinged Door Orientation

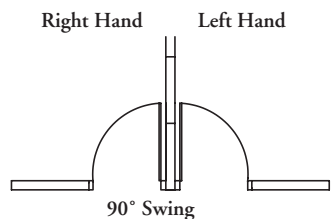

The Pivot and Hinged Glass Doors permit a 90° swing

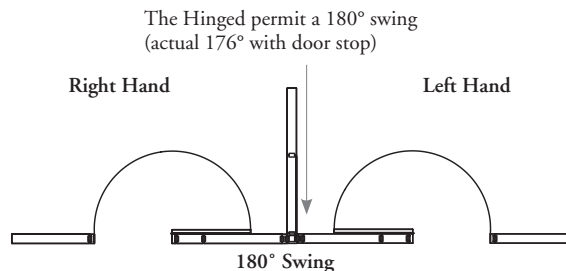

The Hinged permit a 180° swing (actual 176° with door stop)

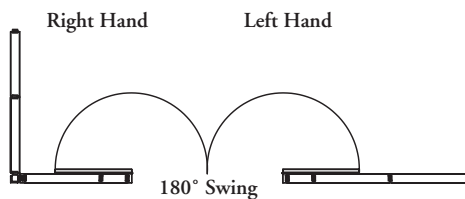

- For the Hinged Double Door, both doors must swing in the same direction
- Door is hinged on frame side only

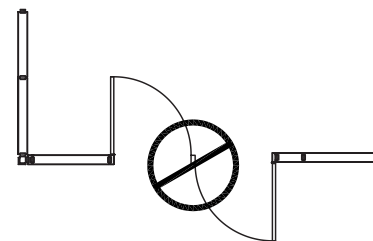

Wall Starts & Filler Panels

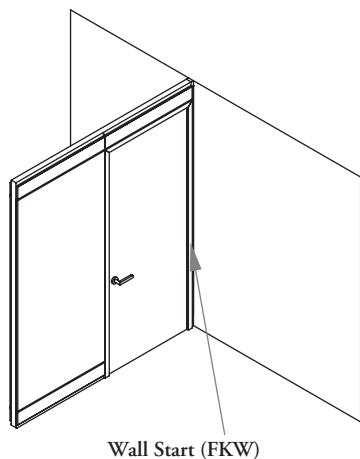

Doors **cannot** be located adjacent to Wall Starts (FKW), Wall End (FKE), Filler Panels (FPF) or On-Off 3-Way Modules (FKM3) (Wall Start & Filler Panels shown).

Doors can be attached to Adjustable Wall Start (FPKW).

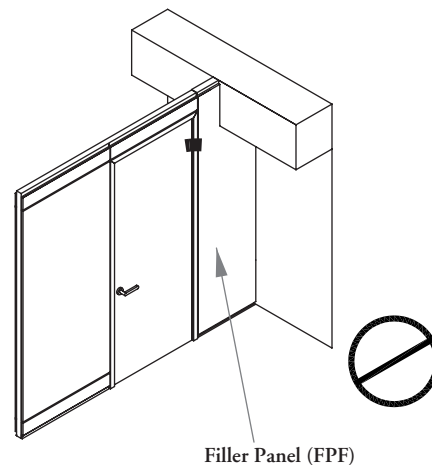

All Doors excluding the 84" high Barn Door may be planned adjacent to any wall type. Corresponding frame kit produces must be specified.

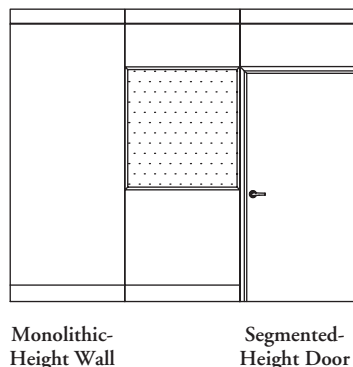
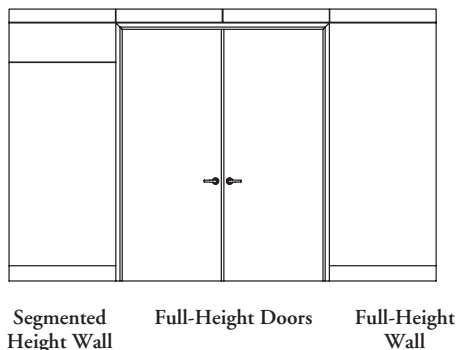

planning with single barn doors

The following rules should be considered when planning with Single Barn doors.

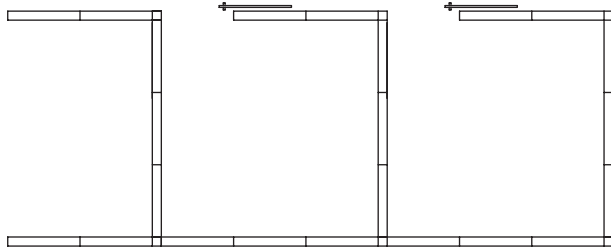
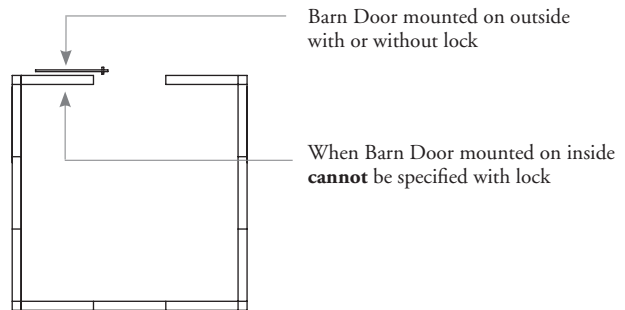
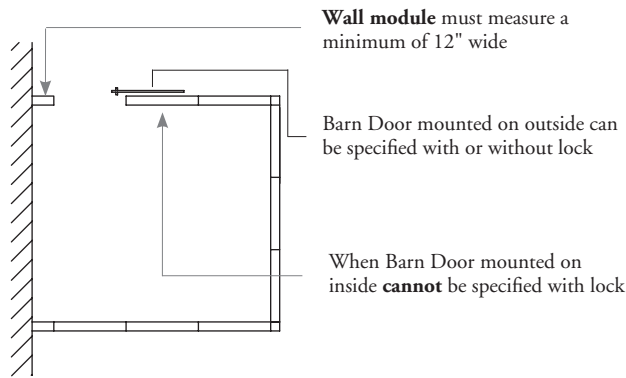

When the Barn Door is located next to a corner connection with an adjoining wall module, the Barn Door **must be** mounted on the outside of a wall run

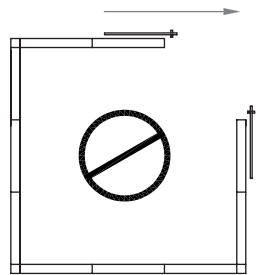

Two Barn Doors **cannot** be mounted to meet at a corner

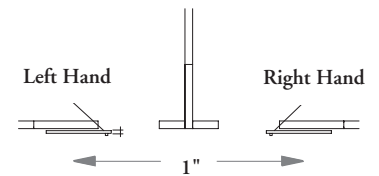

Door slide orientation must be specified for the Single Barn Door. The slide orientation is identified as right- or left-handed according to the direction of travel

When the Barn Door is located next to a corner connection **without** an adjoining wall module, a mechanical fastener securing the corner connection to the floor is required and the Barn Door must be mounted on the outside of the wall run.

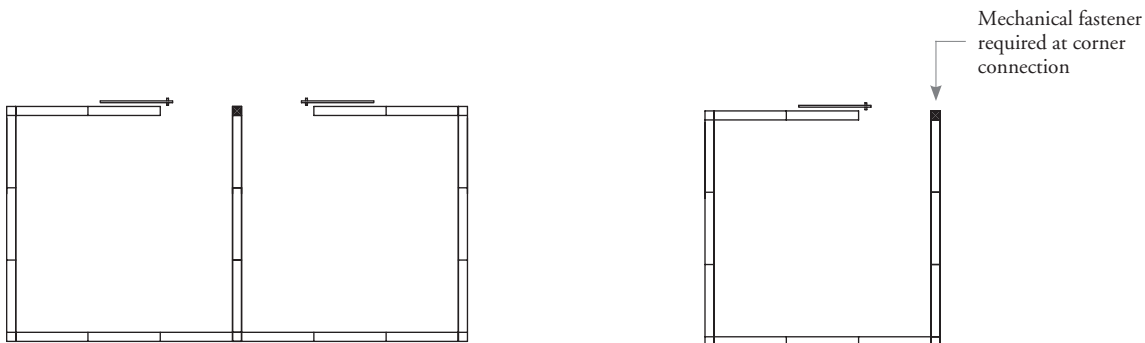

planning with double barn doors

The following rules should be considered when planning with Double Barn doors.

Doors can be planned on inside or outside of wall modules. If specified with locks doors must be outside.

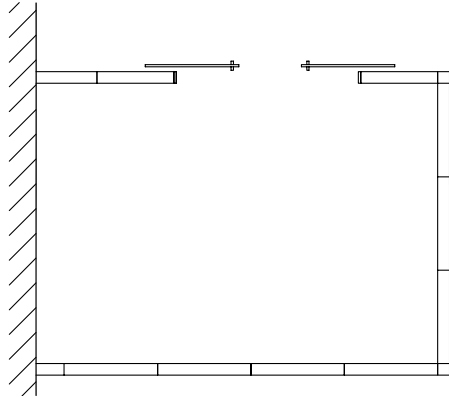

Furniture **cannot** be hung within door modules.

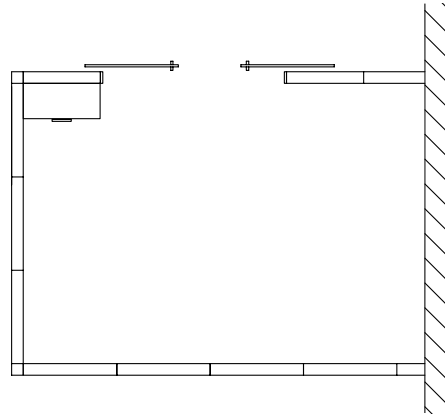

Door frame **cannot** connect to a two way corner connection.

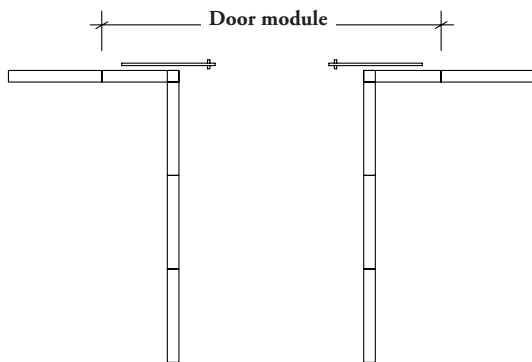

- Door frame can connect to a wall run with a three-way 180° off-module connection (FKM3_2)
- Minimum distance between a door frame and a return wall run is 6"

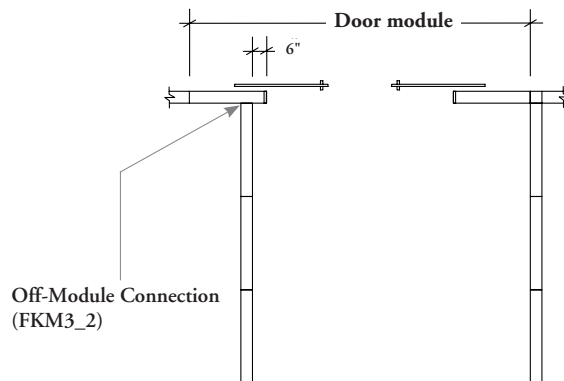

planning with double barn doors (continued)

The following rules should be considered when planning with Double Barn doors.

A Three-Way Corner connection is required between adjacent barn doors.

Each Glass Barn door needs four supporting points.

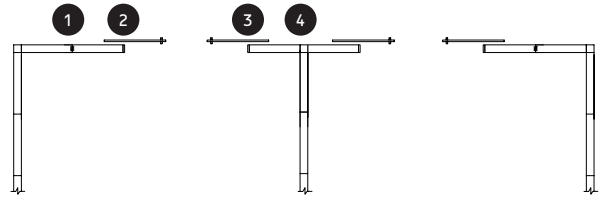
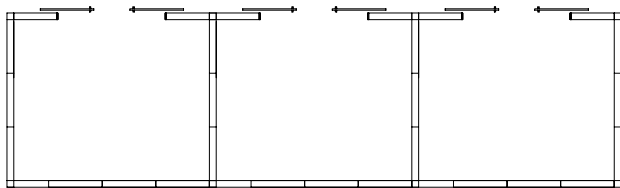

Shared post **cannot** be used between two double barn doors.

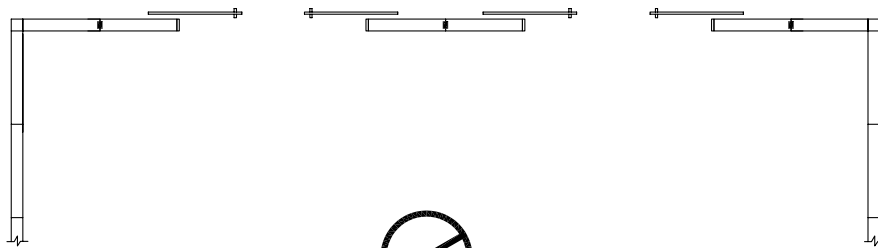

When doors meet at 90° corner, at least one of two door sets should open from outside.

Two sets of doors meeting at a 90° corner can **not** be mounted on the inside.

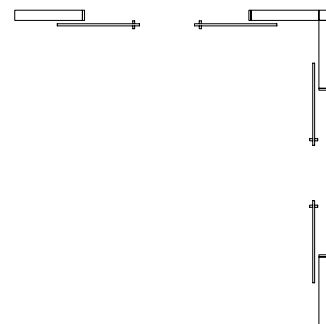
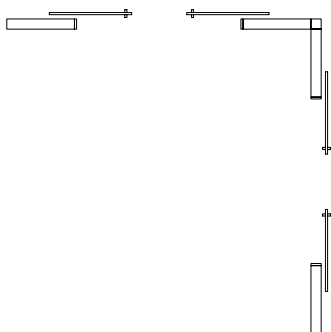

portrait – frame kits &
components

portrait – frame kits & components

FRAME KIT OVERVIEW	90
CEILING & BASE CHANNEL BASICS	91
PLANNING WITH CEILING CLIPS	92
VERTICAL POST BASICS	93
PLANNING WITH HORIZONTAL RAILS	94
PLANNING WITH VERTICAL POST	95
VERTICAL POST PACKAGE SELECTOR	96
CORNER & MODULE CONNECTION OVERVIEW	97
90° CORNER CONNECTION BASICS	98
PLANNING WITH 90° CORNER CONNECTIONS	99
135° CORNER COVER BASICS	100
PLANNING WITH 135° CORNER COVERS	101
ARTICULATING CORNER BASICS	102
PLANNING WITH ARTICULATING CORNERS	103
MODULE CONNECTION BASICS	105
WALL GASKET BASICS	106
WALL START & END BASICS	107
PLANNING WITH WALL STARTS & ENDS	109
PLANNING WITH MODULE CONNECTIONS	110
DOOR FRAME BASICS	112
PLANNING WITH DOUBLE BARN DOOR FRAMES	113
FASCIA REVEAL INSERTS	114
FRAME KIT COMPONENT BASICS	115

frame kit overview

Frame kits are used together to create the structural frame of the Altos wall. Frame kits are specified after the Fascia configurations has been determined.

Two-Way 90° Corner Cover (FKCN90) and Hardware for Altos Corner Connections (FKCH90) (shown)

Also Available:

FKCN120 and FKCH120, FKCN132 and FKCH132, FKCN133 and FKCH133, FKCN180 and FKCH180, FKCA4, FKCA2, FKCA3

The Corner Covers for 135° (FKCN132, FKCN133, FKCN180, FKCN90, FKCN120) can be found in the Fascias Section.

Recycled Cotton Insulation (FAI) (not shown)

Recycled cotton insulation used within the Altos wall cavity to improve STC. Available as a 50' x 4' roll cut to size on site.

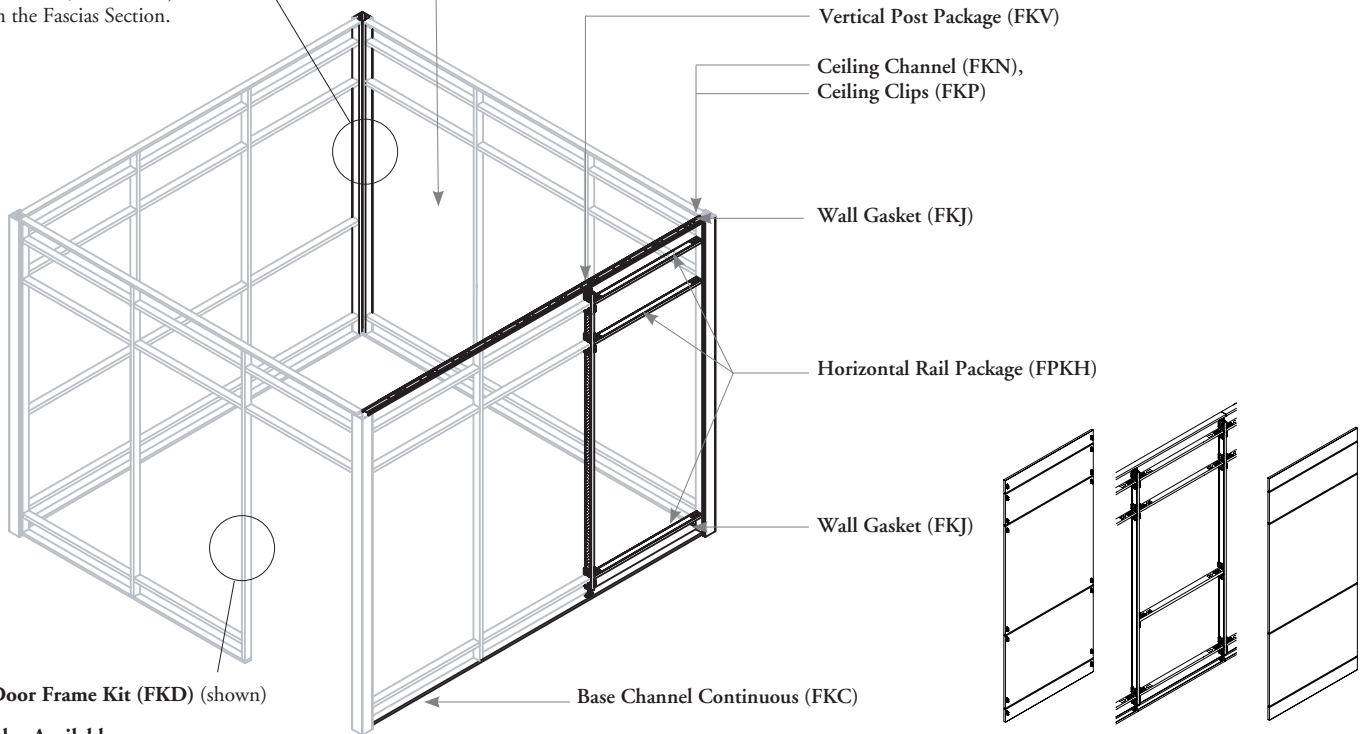

Frame Kit packages for vertical posts and horizontal rails are specified to coordinate with Fascia elevations chosen

Door Frame Kit (FKD) (shown)

Also Available:

FKTF, FKTS, FKRT, FPBGSJ, FPBSR, FPBSSJ

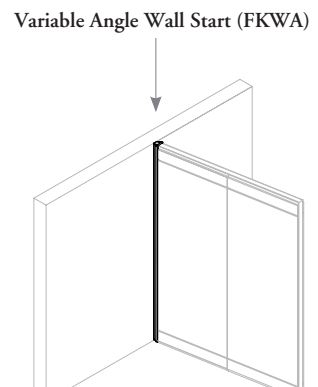
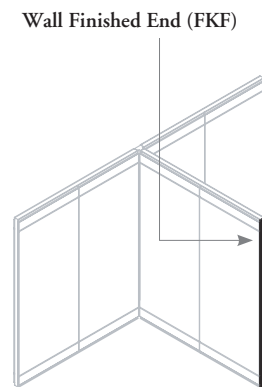
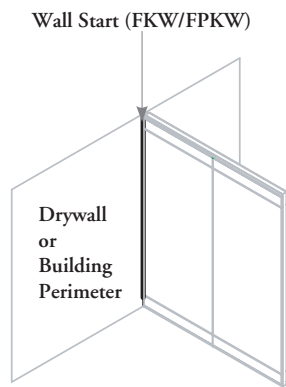
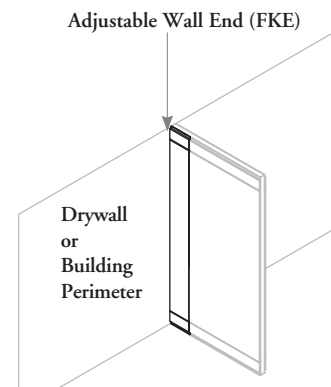

ceiling & base channel basics

A Ceiling Channel is required over entire wall run, including openings and corner connections in all applications of Altos wall system.

Ceiling Clip (FKP)

- Is a non-permanent method of connecting the ceiling channel to the suspended ceiling
- **Cannot** be connected to all types of ceilings – site verification required
- Non-marking and need to be ordered separately from ceiling channel
- Accommodate the changing wall locations without defacing the T-Bar

Ceiling Clip Upper

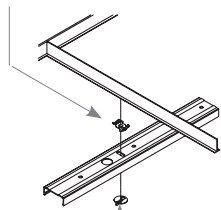

Ceiling Clip Lower

Horizontal Grommet (FBG)

- (not shown)
- The Horizontal Grommet provides a finish to the Horizontal Rail cut outs
- Optional for use with solid and fabric fascias. **Cannot** be used with Glass Fascias



Wall Gasket (FKJ)

- Is a light and sound seal between the bottom of the wall system and the finished floor and the top of the wall system and the ceiling
- Minor height variations in floor and ceiling surfaces may be concealed by the wall gasket – available in 10'-0" lengths only

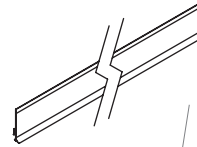

Vertical Reveal Cover Kit (FKJC)

The Vertical Reveal Cover provides a trim for vertical post when Platinum or Very White gaskets are used



Horizontal Rail Package (FPKH)

- Consist of horizontal rails and one Base Channel – Modular (FPKB)
- Horizontal pass-through of electrics and communications is possible through the openings in the horizontal rails
- One Package is shared between the inner and outer elevation of a wall module
- Are universal and are used for both Solid and Glass Fascias
- **Must** specify base and ceiling fascia height being used
- When the 4" fascia is specified, female mounting clips are installed on the Horizontal Rail. When the 6" fascia is specified then female clips are mounted on the Vertical Posts

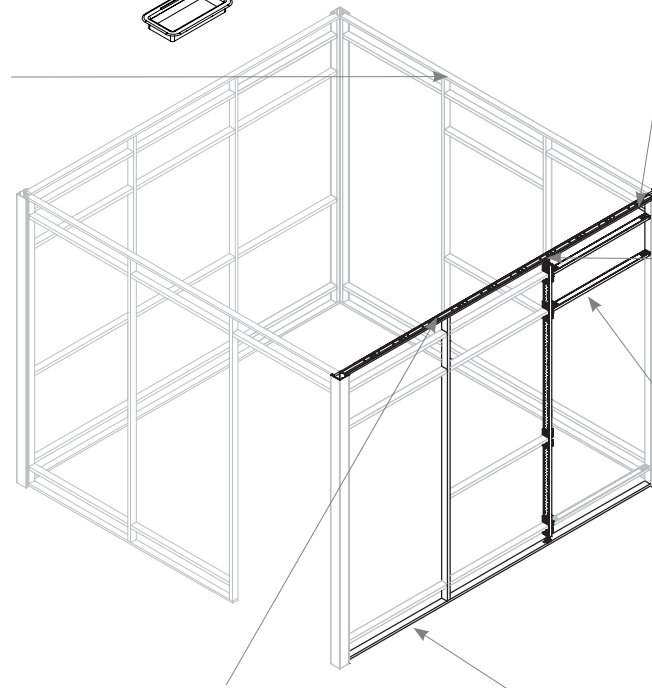

To determine the number of Ceiling Channels (FKN) required for the length of a wall run, take the total linear footage multiplied by 0.14

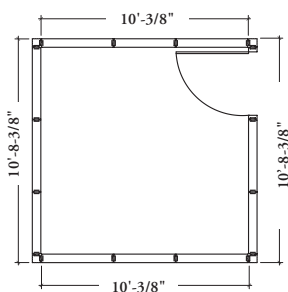

Ceiling Channel (FKN)

- Attaches to the ceiling and supports the Vertical Post Packages
- Is an inverted steel U-channel start and can be cut to size on site
- Holes are punched into the Ceiling Channel to facilitate power and communications feed from the ceiling into the wall
- Is available in 10'-0" lengths only
- Can be attached to ceiling at any angle

Ceiling Channel

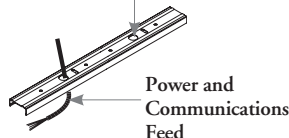

Base Channel (FKC)

- Horizontal frame work of all wall assemblies
- Gap tape is provided along the underside of the channel to add stability and an acoustic barrier without mechanical attachments to the floors
- Can also be mechanically fastened to the floor if a more secure or permanent attachment is required (hardware not included)
- Available in 10" widths only

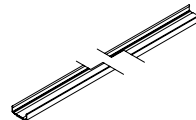

12", 18", 24", 30", 40", 42", 48" and in 1" increments from 12" - 48"

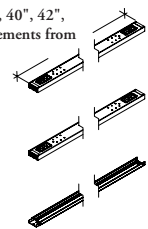

planning with ceiling clips

The following should be considered when planning with Ceiling Clips.

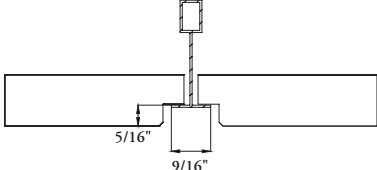
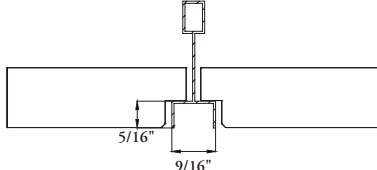
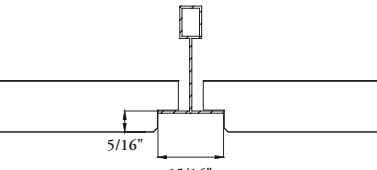
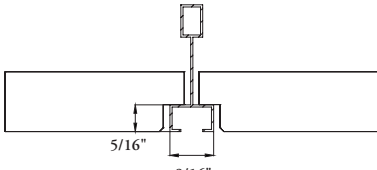
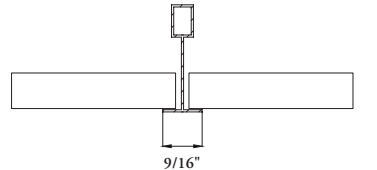
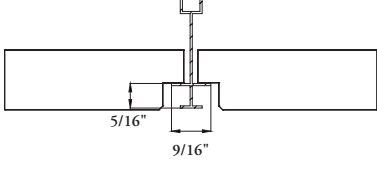
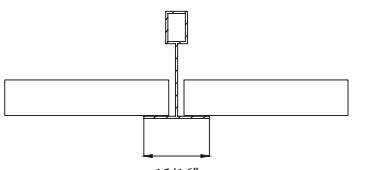
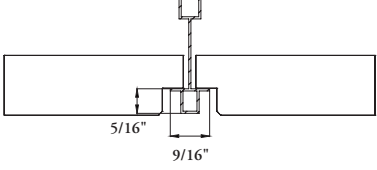
Ceiling Profile	Ceiling Clip	Ceiling Profile	Ceiling Clip
	FKP1 + FKP3		FKP5
	FKP2 + FKP3		FKP5
	FKP1		FKP5
	FKP2		FKP5

- 9/16" and 15/16" Ceiling Clips (FKP1 and FKP2) are used for flat and recessed tiles with flat grid only
- For recessed tile application, Spacer Ceiling Clips (FKP3) is required for use with FKP1 or FKP2
- 9/16" Ceiling Clip (FKP5) is used for recessed tiles with various types of box grid

application guide

vertical post basics

The Vertical Post Package extends from finished floor to finished ceiling and is the vertical support of the Altos frame.

- Vertical Post Packages are universal and also fulfill the vertical post requirements for door openings
- The levelers allow for adjustment of $+1-1/2$ / -0.5 " independently at the top and $+1-1/2$ / -0.5 " independently at the bottom
- **Must** specify base and ceiling fascia height being used

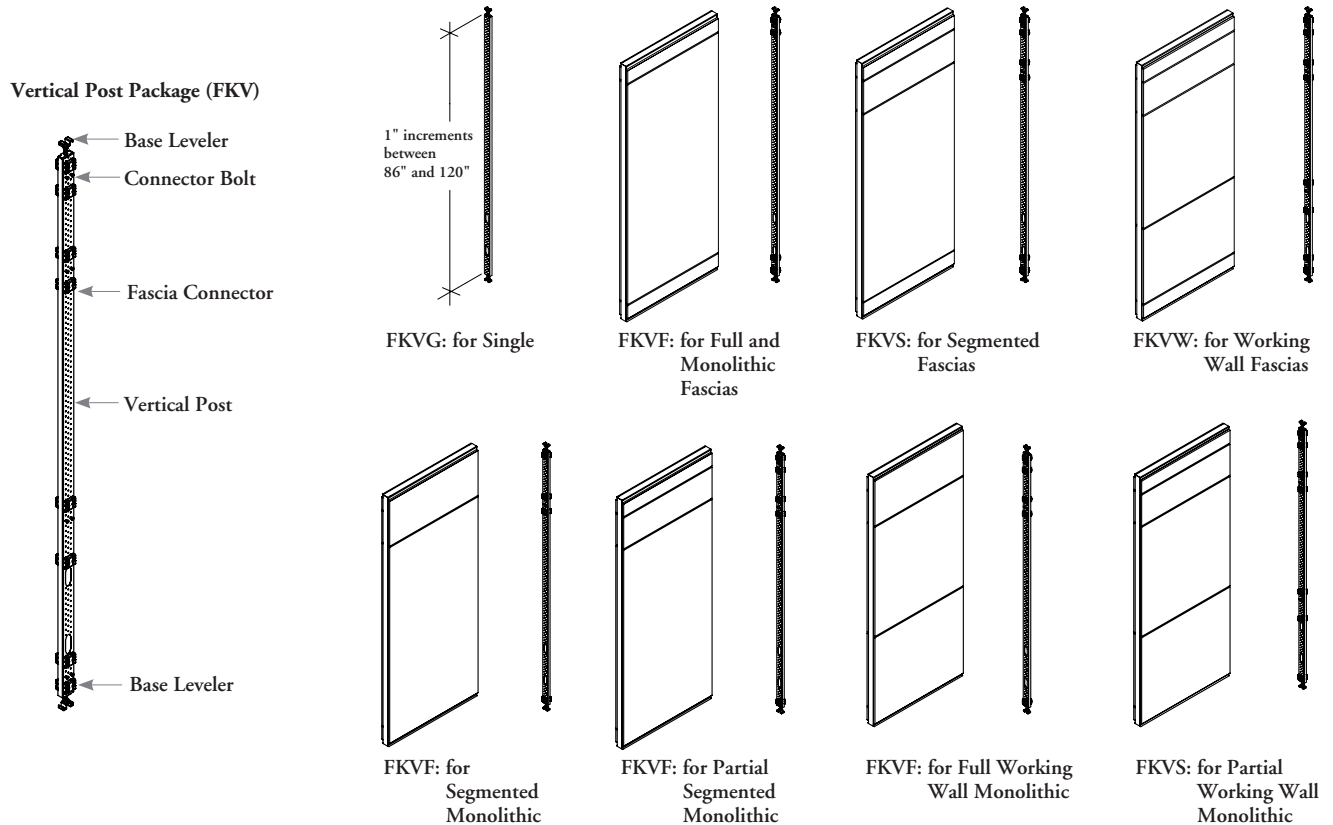
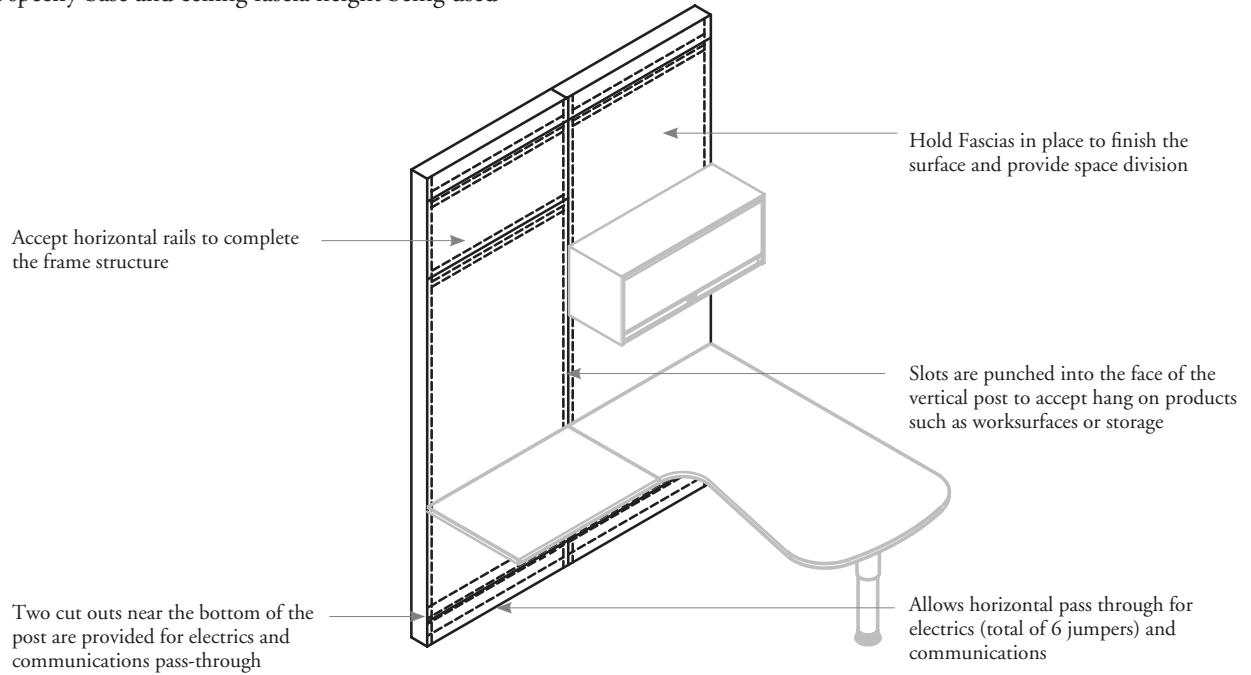

planning with horizontal rails

Horizontal Rail Packages include the appropriate number of horizontal rails and one Base Channel – Modular. Each Horizontal Rail Package corresponds to the wall elevation it will support. The following chart demonstrates the components included.

Monolithic Fascia Package (FPKHM)

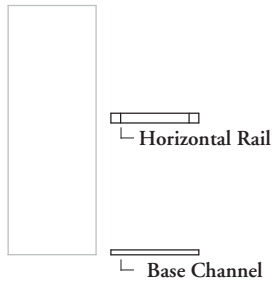

Full Fascia Package (FPKHF)

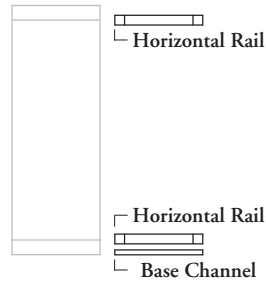

Segmented Fascia Package (FPKHS)

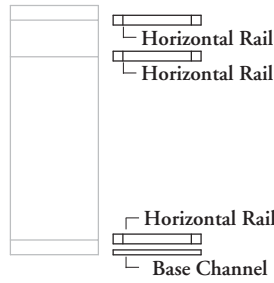

Working Wall Fascia Package (FPKHW)

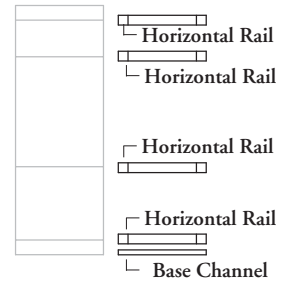

Monolithic Fascia Package (FPKHM)

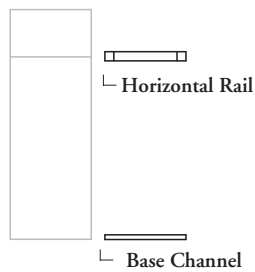

Full Fascia Package (FPKHF)

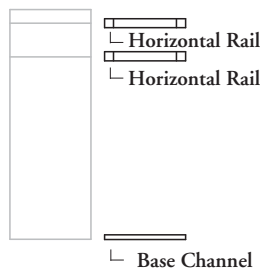

Full Fascia Package (FPKHF)

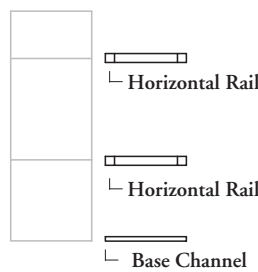

Segmented Wall Fascia Package (FPKHS)

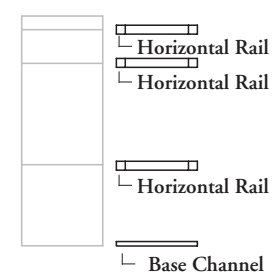

Full-Height Door (FPKHG)

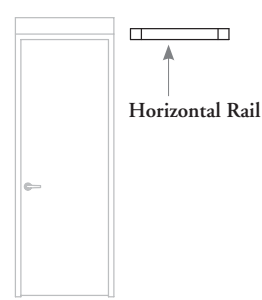

Segmented-Height Door x 2 (FPKHG)

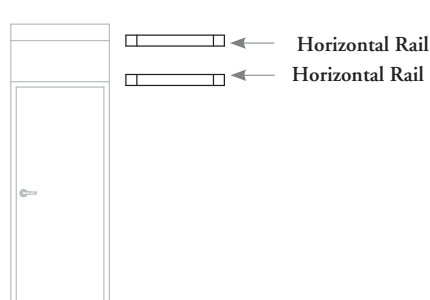

planning with vertical post

There are three steps in specifying Vertical Post Packages; determining the number and placement of Vertical Post Packages required, selecting appropriate Vertical Post Package type and specifying Vertical Post Package height

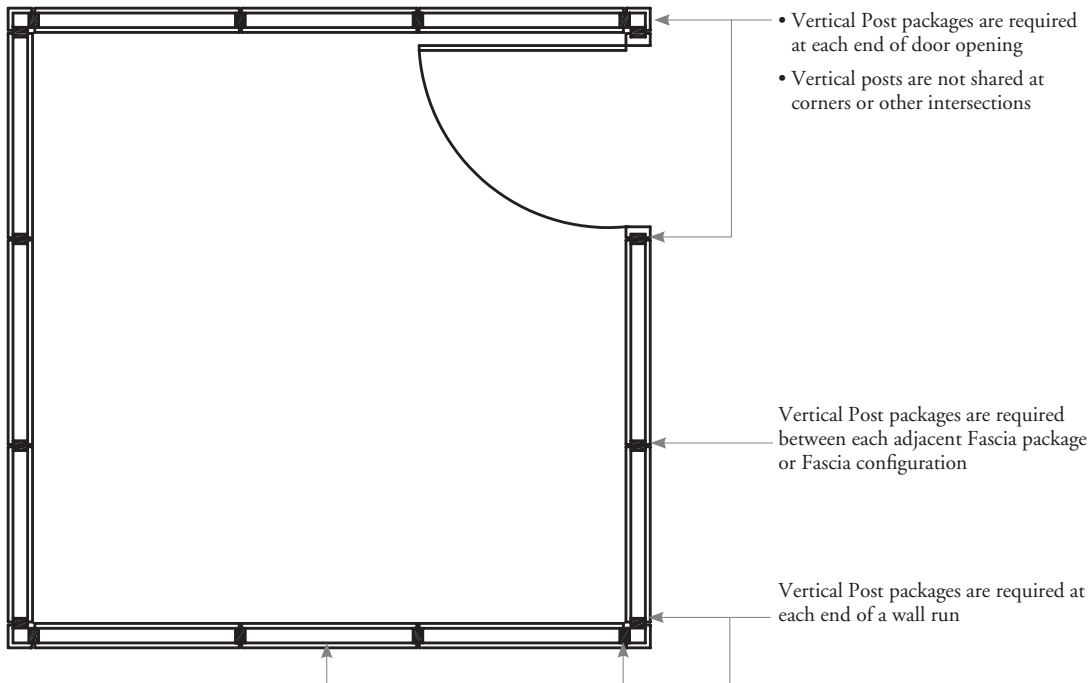

- The starting point for selecting the proper Vertical Post Package is at the inner and outer elevations of each wall module that will share a Vertical Post Package
- The Fascia packages or Fascia configurations that create these elevations determine which type of Vertical Post Package to select
- Always select the post for the highest connector requirements



Inner Elevation Segmented Wall require Segmented Vertical Post Packages (FKVS)



Outer Elevation of Wall Module Full Wall requires Full Vertical Post Package (FKVS), therefore, Vertical Post Package (FKVS) should be specified because all post requirements are the same

Full-Height Door requires Full Vertical Post Package (FKVF)

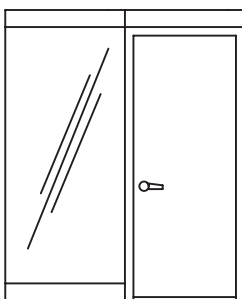

- Outer Elevation Full Wall requires Full Vertical Post Package (FKVF)
- Therefore Full Vertical Post Package (FKVF) should be ordered
- Inner Elevation Full-Height Door requires Full Vertical Post Package (FKVF)

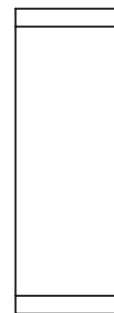



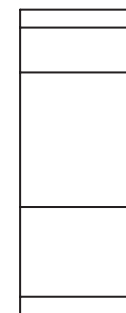









Outer Elevation of Wall Module Full Wall requires Full Vertical Post Package (FKVF)

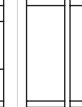

Inner Elevation of Wall Module Working Wall requires Working Wall Vertical Post Package (FKVW) therefore, Vertical Post Package (FKVW) should be ordered

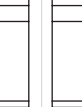
vertical post package selector

This chart demonstrates which Vertical Post Package should be selected for each application.

		Single Wall Modules: Inner and Outer Elevations											
		Mono + Mono FKVF	Mono + Full FKVF	Mono + Seg FKVS	Mono + WW FKVW	Full + Full FKVF	Full + Seg FKVS	Full + WW FKVW	Seg + Seg FKVS	Seg + WW FKVW	WW + WW FKVW	F/H Door FKVF	Seg Door FKVS
													
Adjacent Wall Modules: Inner and Outer	Mono + Mono FKVF	FKVF	FKVF	FKVS	FKVW	FKVF	FKVS	FKVW	FKVS	FKVW	FKVW	FKVF	FKVS
	Mono + Full FKVF	FKVF	FKVF	FKVS	FKVW	FKVF	FKVS	FKVW	FKVS	FKVW	FKVW	FKVF	FKVS
	Mono + Seg FKVS	FKVS	FKVS	FKVS	FKVW	FKVS	FKVS	FKVW	FKVS	FKVW	FKVW	FKVS	FKVS
	Mono + WW FKVW	FKVW	FKVW	FKVW	FKVW	FKVW	FKVW	FKVW	FKVW	FKVW	FKVW	FKVW	FKVW
	Full + Full FKVF	FKVF	FKVF	FKVS	FKVW	FKVF	FKVS	FKVW	FKVS	FKVW	FKVW	FKVF	FKVS
	Full + Seg FKVS	FKVS	FKVS	FKVS	FKVW	FKVS	FKVS	FKVW	FKVS	FKVW	FKVW	FKVS	FKVS
	Full + WW FKVW	FKVW	FKVW	FKVW	FKVW	FKVW	FKVW	FKVW	FKVW	FKVW	FKVW	FKVW	FKVW
	Seg + Seg FKVS	FKVS	FKVS	FKVS	FKVW	FKVS	FKVS	FKVW	FKVS	FKVW	FKVW	FKVS	FKVS
	Seg + WW FKVW	FKVW	FKVW	FKVW	FKVW	FKVW	FKVW	FKVW	FKVW	FKVW	FKVW	FKVW	FKVW
	WW + WW FKVW	FKVW	FKVW	FKVW	FKVW	FKVW	FKVW	FKVW	FKVW	FKVW	FKVW	FKVW	FKVW
	F/H Door FKVF	FKVF	FKVF	FKVS	FKVW	FKVF	FKVS	FKVW	FKVS	FKVW	FKVW	FKVF	FKVS
	Seg Door FKVS	FKVS	FKVS	FKVS	FKVW	FKVS	FKVS	FKVW	FKVS	FKVW	FKVW	FKVS	FKVS

Vertical post packages are available in heights that increase in 1" increments between 8 and 10 feet (i.e. 8'-0", 8'-1", 8'-2"...10'-0"). These heights correspond to the dimension between finished floor to the underside of the finished ceiling.

When accessing pricing for Vertical Post Packages, you will be presented with the following height ranges:

Height Code	Height Range	Height Code	Height Range
102	86"–102"	108	103"–108"
114	109"–114"	120	115"–120"

These height ranges are for pricing only. Be sure to indicate the exact height required for the Vertical Post Package in the product code.

corner & module connection overview

Altos allows 90°, 135° and 180° connections in two-way, three-way and four-way configurations, as well as mid-wall connections.

- All connections allow for passage of power and communications except FKCA2 and FKCA3
- Partial height connections are not possible
- All connections are available for ceiling heights from 86" to 120" in 1" increments
- The Corner Covers for 135° (FKCN132, FKCN133, FKCN180, FKCN90, FKCN120) can be found in the Fascias Section

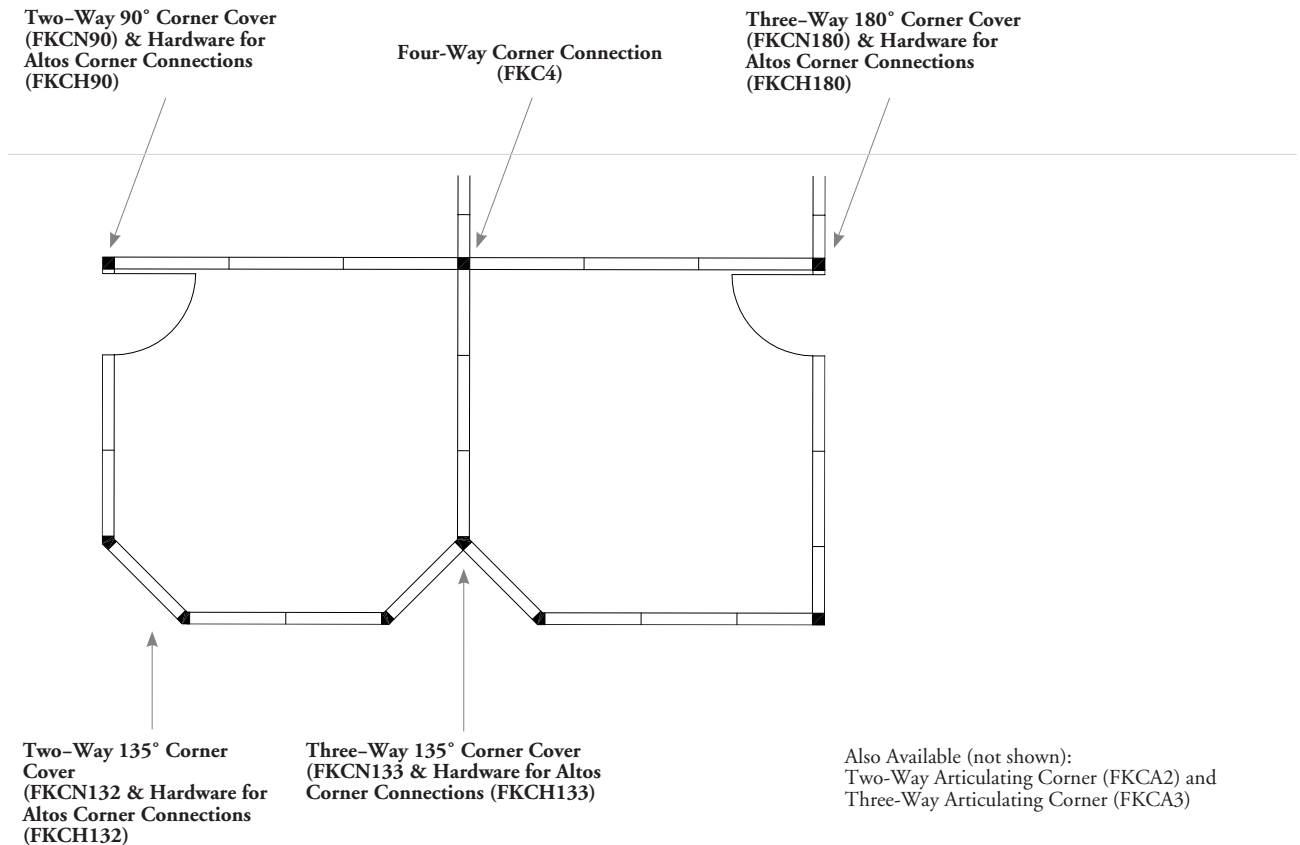

modular connections

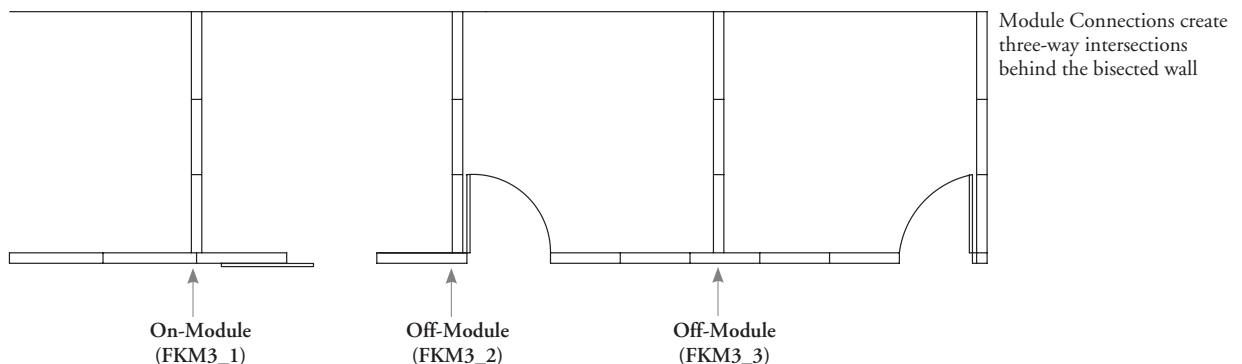

90° corner connection basics

Walls can be connected at right angles in two-way, three-way and four-way configurations.

- Brackets connect post packages to form a corner
- The quantity of brackets required may vary according to wall heights or wall material
- Can enclose electrics & communications traveling from wall-to-wall or from ceiling down to glass modules
- Covers for two-Way and three-way corners are in the Fascias Section

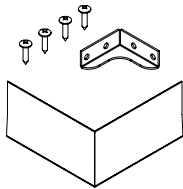

Hardware for Altos Corner Connections (FKCH90)

Provides the framework to connect two walls at 90°.

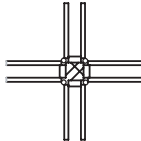

Four-Way Connection 90° Connection (FKC4)

Creates a full-height connection between four walls which are connected at 90°.

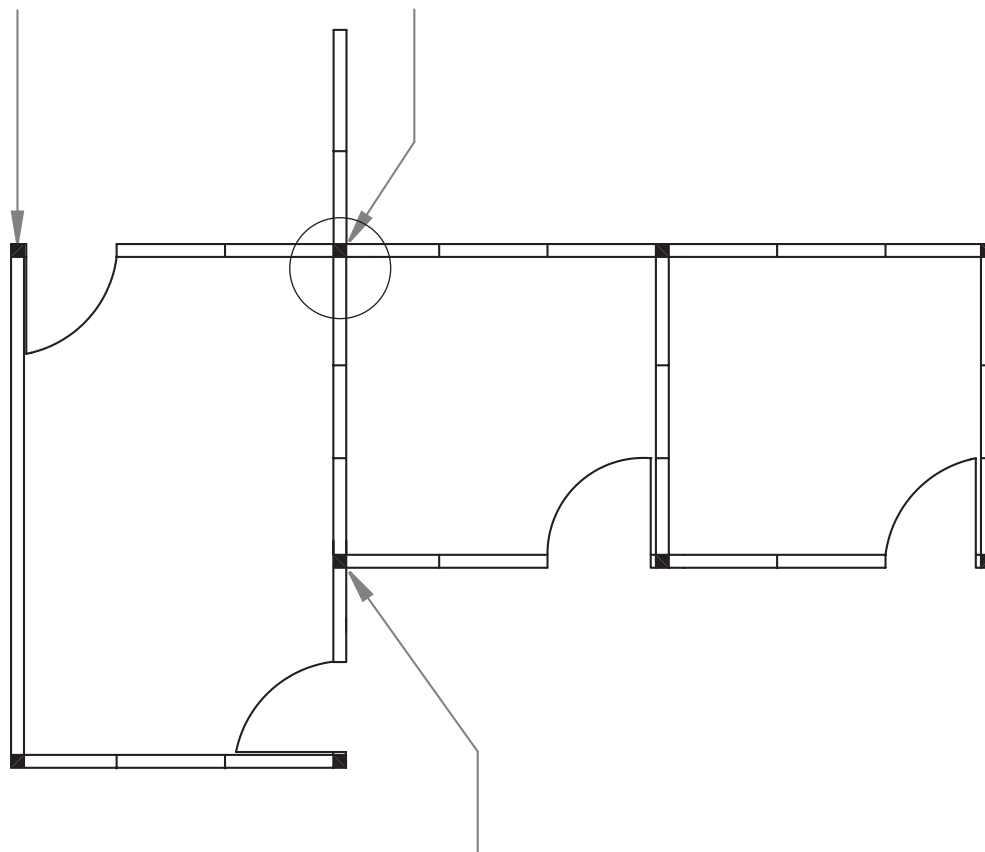

Hardware for Altos Corner Connections (FKCH180)

Provides the framework to connect three walls at 180°.

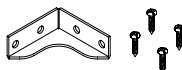

planning with 90° corner connections

The following should be taken into consideration when planning with 90° connections.

For 90° two-way, three-way and four-way corner connections, add 3-15/16"

Wall thickness should be accommodated in the planning process

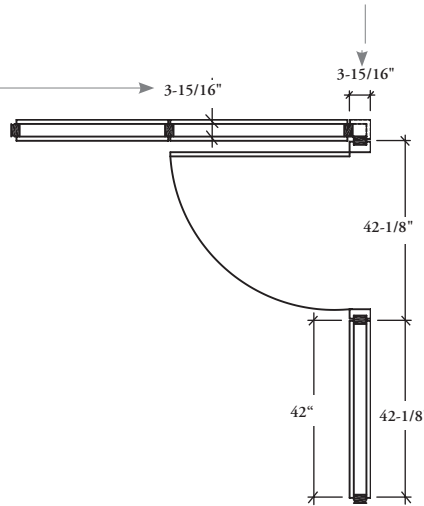

When planning center-line to center-line of two adjacent Vertical Post Packages, add 1/8" to width dimension of Fascia or door to accommodate the connection

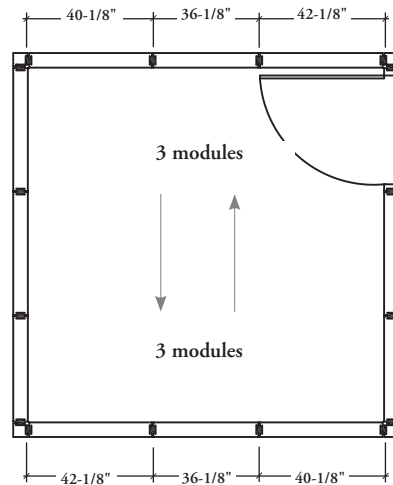

- When two walls are opposite one another with a wall run between them, the number of wall modules and connections on the opposite walls must be the same
- This is to maintain the same dimensions and creep in both parallel wall lengths

Corner connections enclose electric and communications lines traveling from wall to wall through corners or from the ceiling down to glass modules

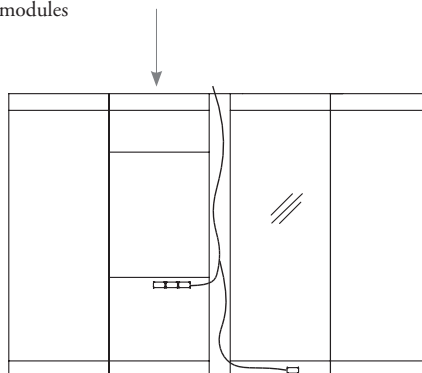

135° corner cover basics

Walls can be connected at 135° in two-way and three-way configurations.

The Corner Covers (FKCN132, FKCN133, FKCN180, FKCN90, FKCN120) can be found in the Fascias Section.

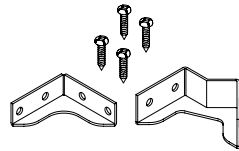

Three-Way 135° Corner Cover (FKCN133)

Provides the framework to connect to three walls at 135°.

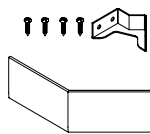
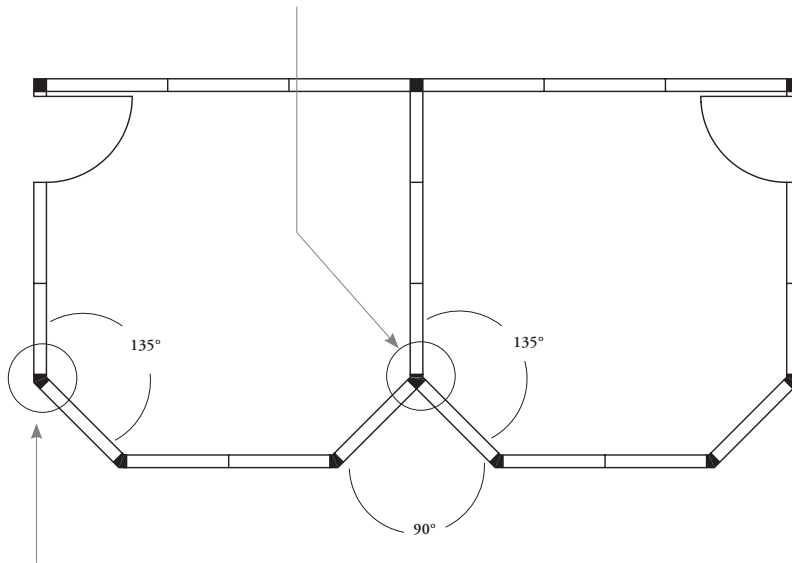

Two-Way 135° Corner Cover (FKCN132)

Provides the frame work for two walls to be connected at 135°.

planning with 135° corner covers

The following should be considered when planning with 135° connectors.

Worksurfaces and mounted storage can be suspended from only one adjacent wall module when two wall modules intersect at 135°.

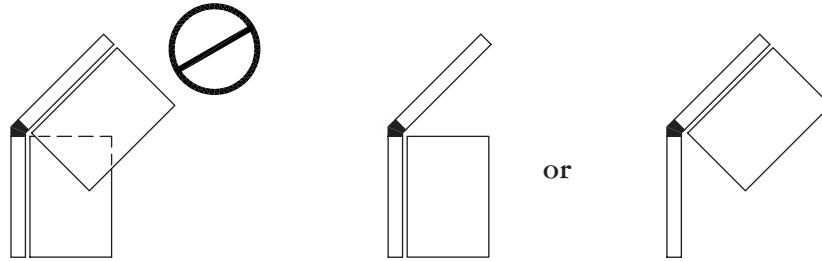

Placement of doors at a 45° does not allow for the suspension of worksurfaces and mounted storage on adjacent wall modules.

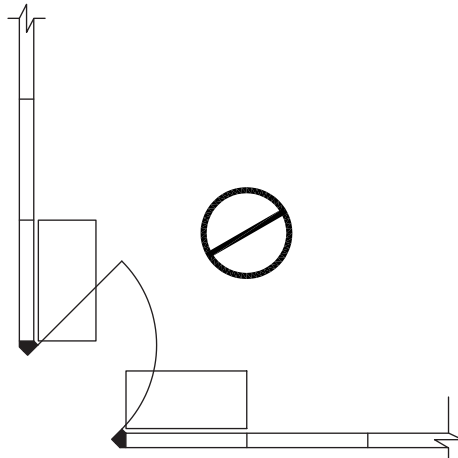

The length of a wall run that includes a 135° connection increases as shown below. Dimensional increase is equal in both directions of wall run.

Two-Way 135° Corner Cover (FKCN132) and Hardware for Altos Corner Connections (FKCH132)

Two-Way 135° Corner Cover (FKCN132) can be found in the Fascias Section.

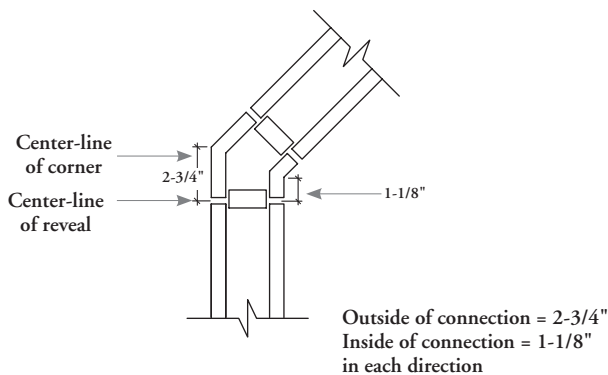

Three-Way 135° Corner Cover (FKCN133) and Hardware for Altos Corner Connections (FKCH133)

Three-Way 135° Corner Cover (FKCN133) can be found in the Fascias Section.

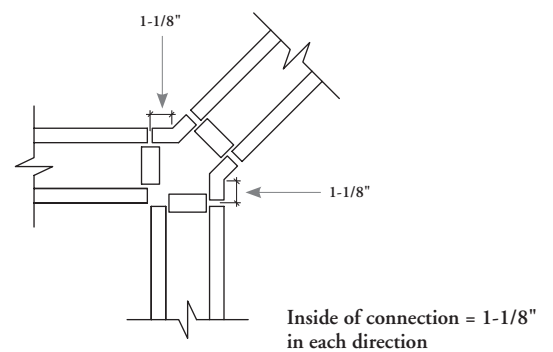

All dimensions are taken from center-line of connection (or point where connection changes direction) to center-line of adjacent reveal between wall modules.

Using the 135° connection may require non-standard wall module widths.

articulating corner basics

Articulating Corners are used to change the angle of an Altos wall run.

- Articulating Corners are available in two-way and three-way configurations
- All Articulating Corners accommodate a range of adjustment from -10° to $+10^{\circ}$
- Finished in Clear Anodized or Painted

Articulating Two-Way Corner (FKCA2)

- Connects two Altos walls between 80° and 100°
- Articulating wall can be on either side of corner
- Provides both the connecting hardware and cover

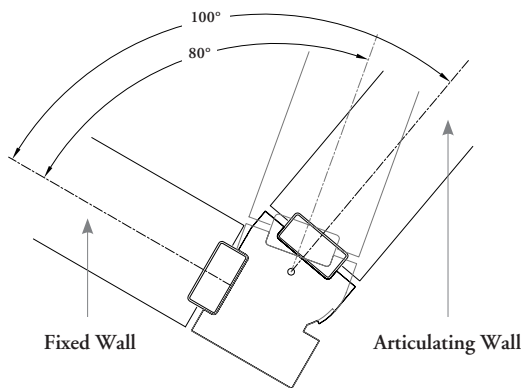

Articulating Three-Way Corner (FKCA3)

- Connects two Altos walls between 80° and 100° with a third fixed Altos wall
- Both sides of corner can be angled independently, each side allows for a maximum 20° of rotation ($\pm 10^{\circ}$)
- Provides both the connecting hardware and cover

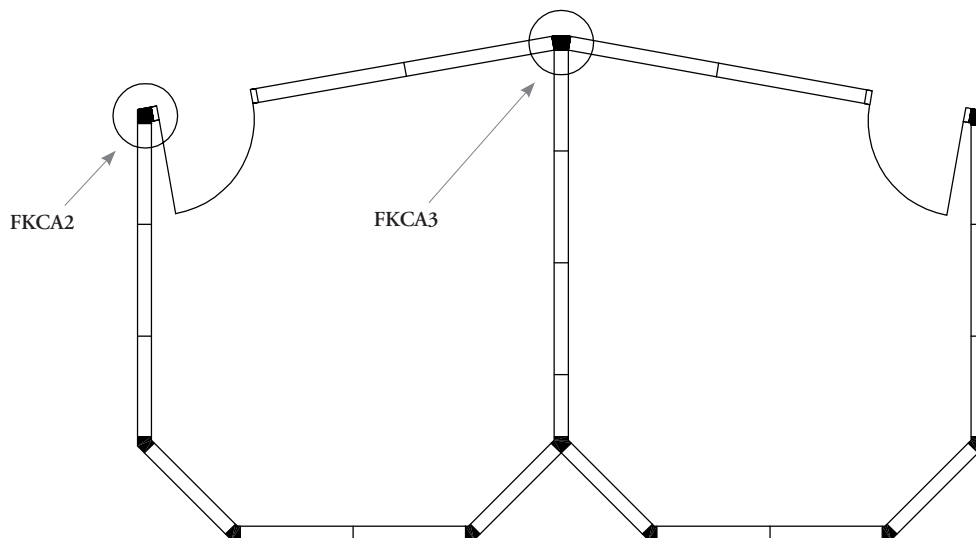
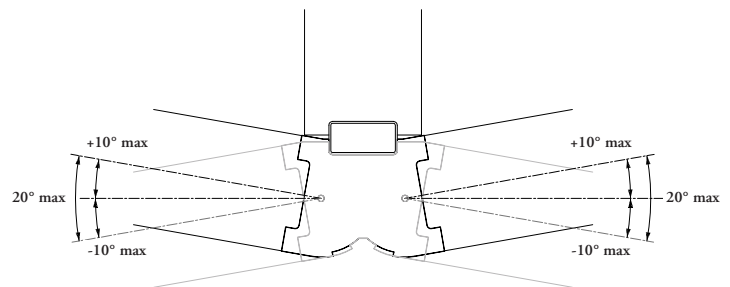

planning with articulating corners

The following should be considered when planning with Two-Way and Three-Way Articulating Corners.

The Articulating Two-Way Corner is available with two pivot point orientations to indicate which wall is the articulating one.

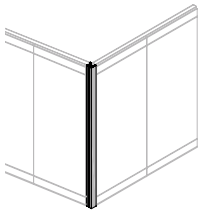

Articulating Two-Way Corner shown with **left** pivot point orientation:

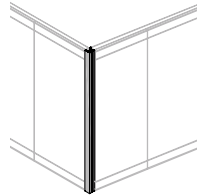

Articulating Two-Way Corner shown with **right** pivot point orientation:

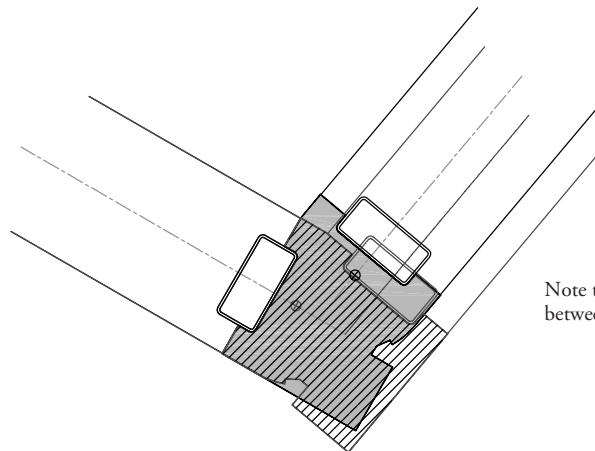
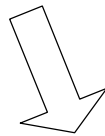
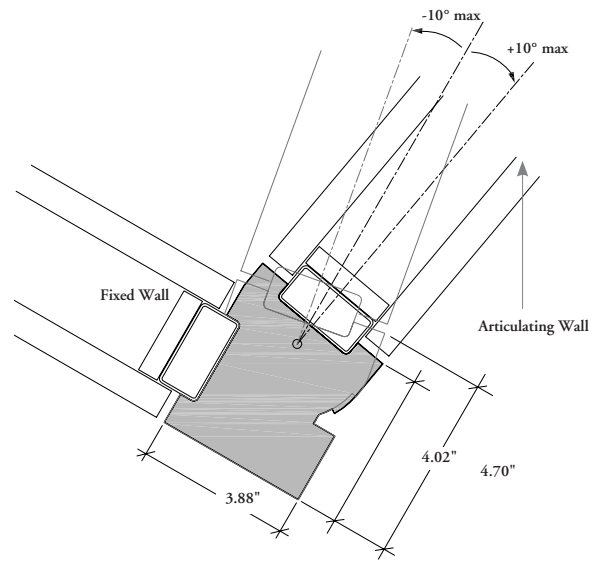
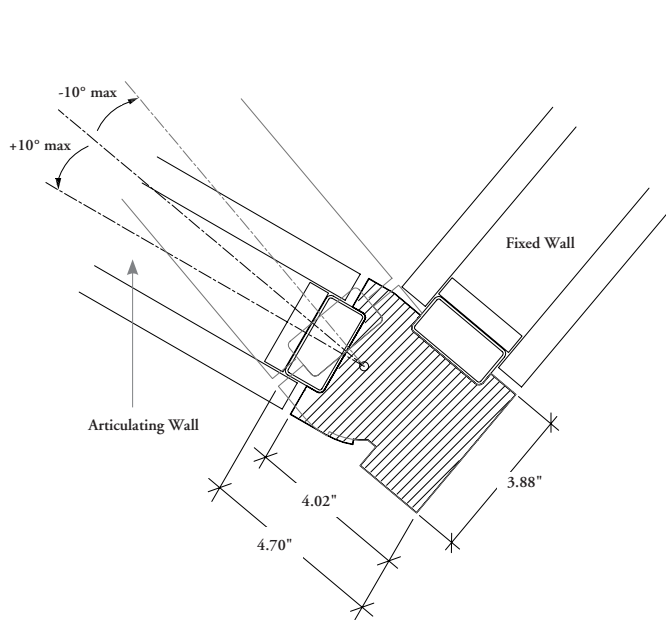

Note the different vertical post positions between left and right pivot point orientation.

planning with articulating corners (continued)

Articulating Corners restrictions with barn door.

When a barn door starts on the inside of a fixed wall with an Articulating Corner, the angle between the barn door front wall and the articulating wall **cannot** be less than 90°.

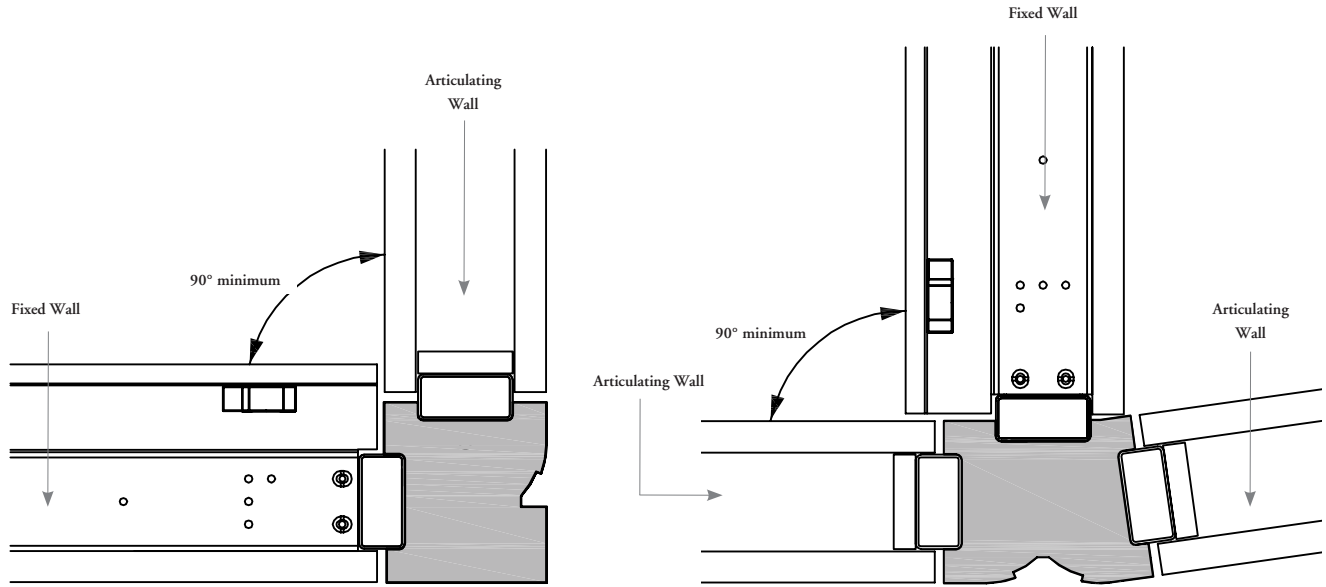

Similarly, when a barn door starts at an articulating wall, the inner angle is restricted to a minimum of 82°.

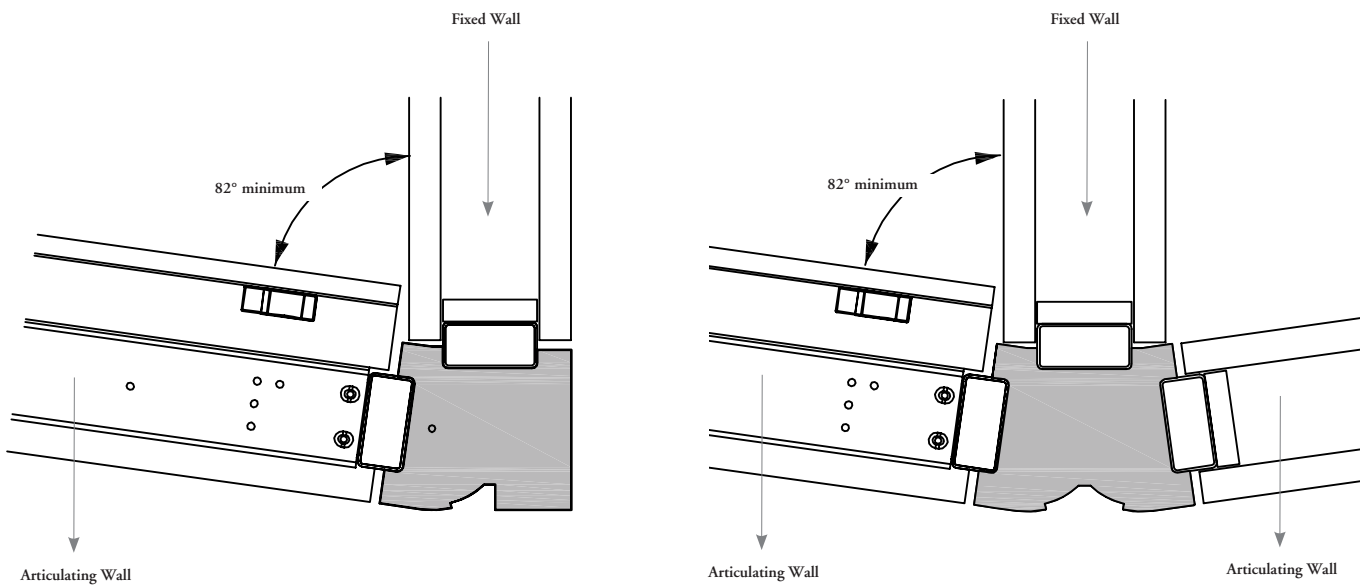

module connection basics

The Three-Way 180° Module Connection provides options for on and off-module connections to an existing wall run.

Three-Way 180° Module Connection (FKM3_1) (On-Module)

- Centers the connection at the vertical reveal between Fascias
- May **not** be attached at any other location

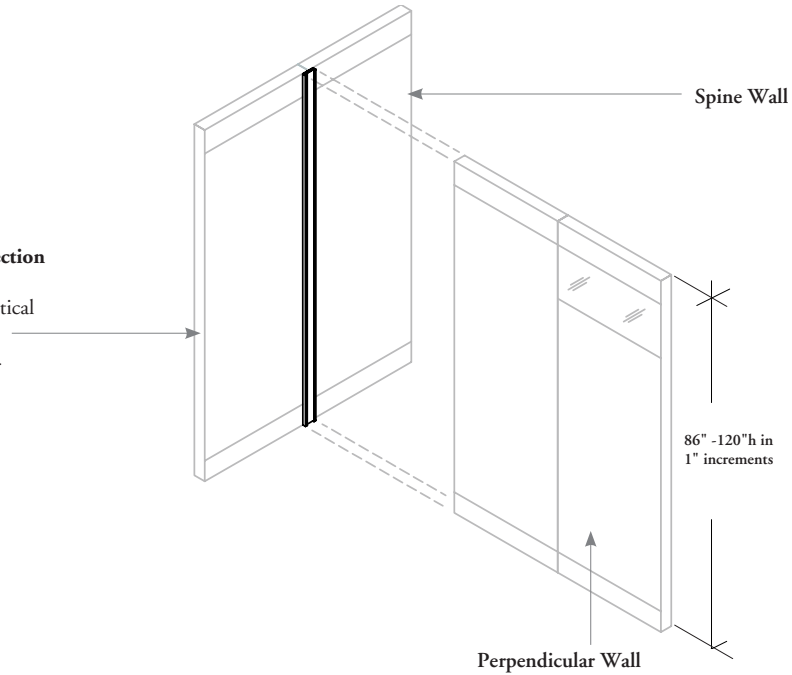

Three-Way 180° Module Connection (FKM3_2) (Off-Module)

- Creates a connection anywhere between reveals of Fascias
- May **not** be used at the vertical reveal
- Can be used at Solid and Double glass Fascias only
- Module Connection adds 1-1/4" Creep – this added dimension comes from the connection interface

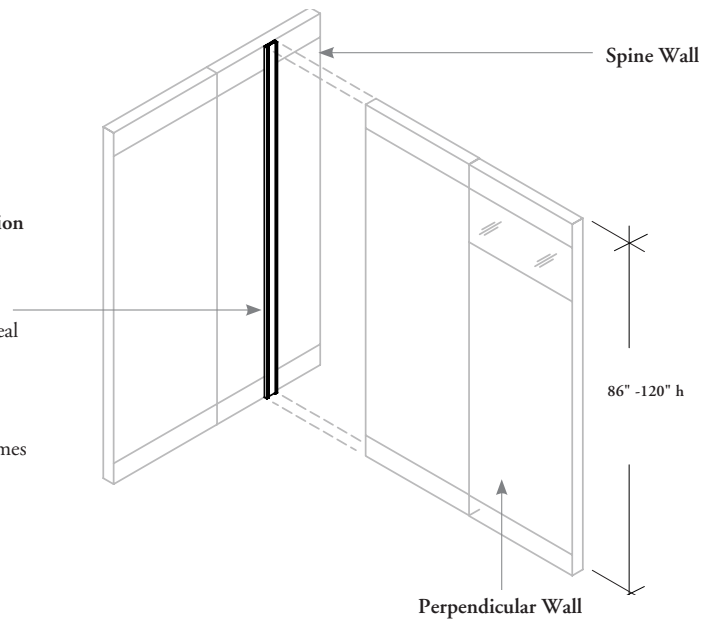

wall gasket basics

The Wall Gasket (FKJ) provides a light and sound seal between the bottom of the wall system and the finished floor and the top of the wall system and the ceiling.

Minor height variations in floor and ceiling surfaces may be concealed by the wall gasket.

determining wall gasket requirements

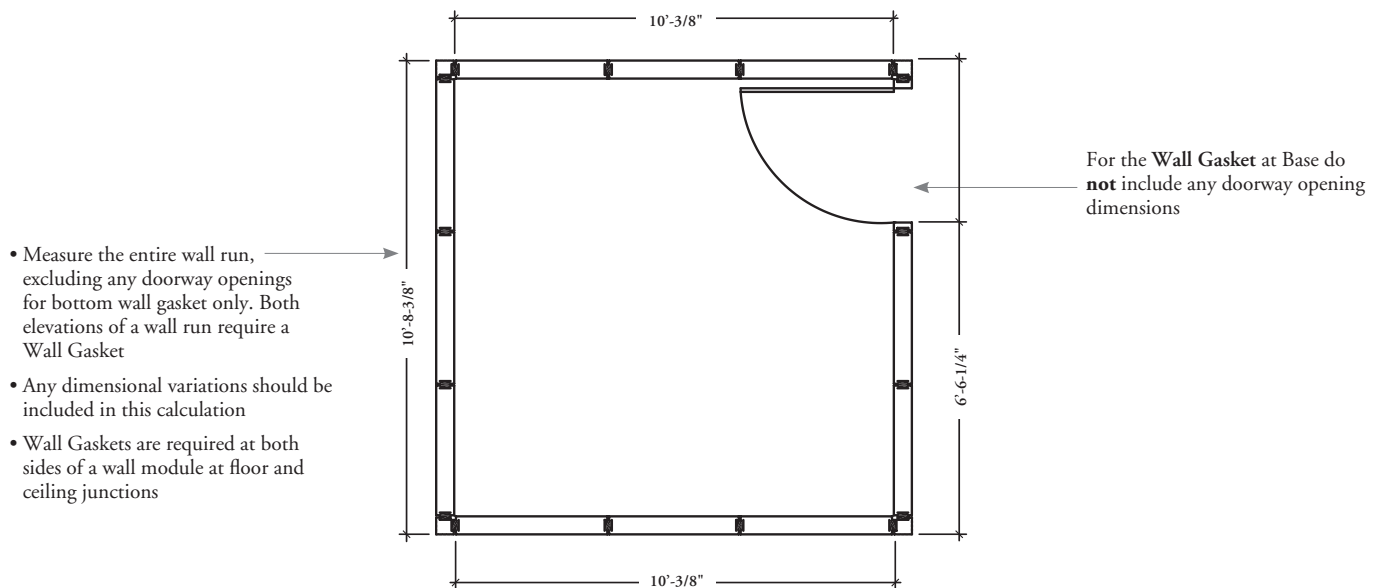

The formula to determine the number of Wall Gaskets (FKJ) required for the length of a wall run is the total linear footage of this product multiplied by 0.40 equals total number of Wall gaskets required.

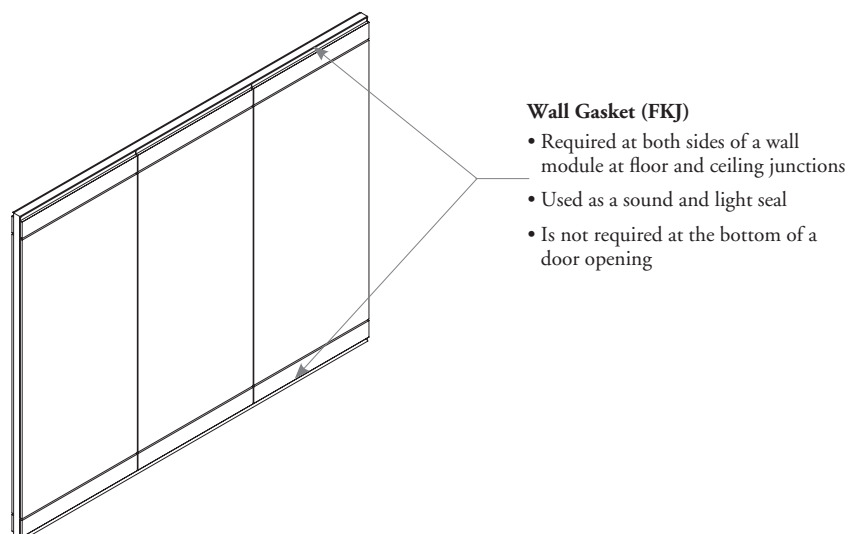

wall start & end basics

Altos offers three types of wall ends for finishing Altos runs; Wall Start, Wall End and Adjustable Wall End.

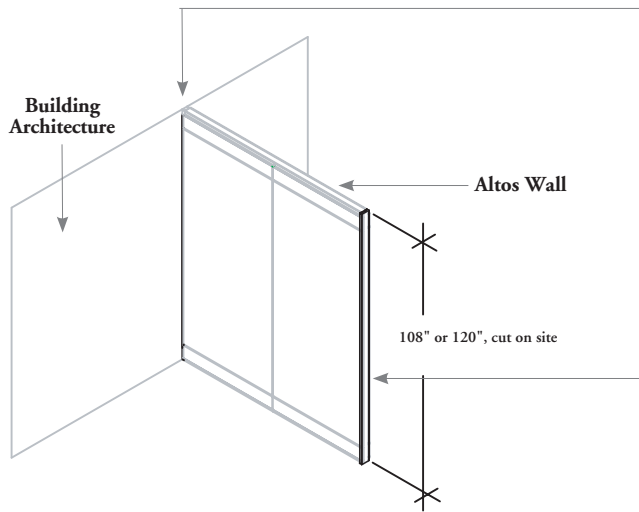

Wall Start (FKW) & Adjustable Wall Start (FPKW)

- Begins or ends a wall run at the building wall, column or mullion and provides a clean connection between the building and the Altos wall
- Can accommodate spacing due to untrue or unlevel wall surfaces
 - Wall Start: +1/4" to -1/4"
 - Adjustable Wall Start: +3/8" to -3/8"
- Adds to the wall run width
 - Wall Start: 1"
 - Adjustable Wall Start: 1-3/4"
- Wall Start can be cut on site
- Intended for minimal gaps in width only; for larger gaps, an Adjustable Wall End (FKEF, FKES, FKEW, FKES) should be specified (same as FKES)
- Wall Start must be used with a Vertical Post package
- The Wall Start does **not** route electrics or communication from the building architecture wall

Wall Finished End (FKF)

- Is used to cap the end of a wall run where there is no connection to another wall run
- Can be cut to size
- Extends from floor to ceiling

Adjustable Wall End (FKEF, FKES, FKEW, FKES)

- Used to allow dimensional adjustment of wall width on-site to complete a wall run where interfacing with building architecture including mullions
- Adjustable Wall End (FKES) accommodates adjustment range of 1-1/2" - 4-1/2" with no horizontal reveals (Flintwood option is only available to 114")
- Adjustable Wall Ends (FKES, FKEF and FKEW) accommodate adjustment range of 3" - 9" and are specified to match Full, Segmented and Working Wall elevations
- All wall connections including Fascia, horizontal rails, base channel and hardware are included but Ceiling Channel (FFN), Ceiling Clips (FKP) and Vertical Posts (FVP) must be ordered separately

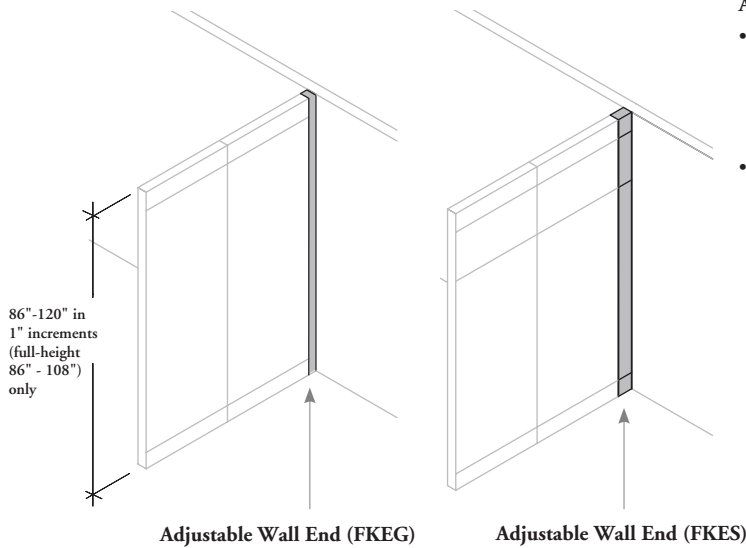

wall start & end basics (continued)

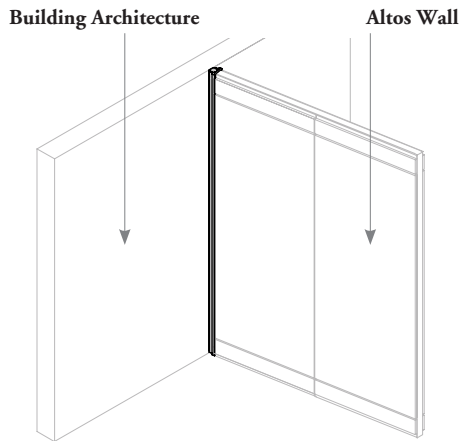

Variable Angle Wall Start (FKWA)

- Used at the beginning or end of a run connecting to building wall, mullion or columns
 - Accommodates minor width variation from $-1/4"$ to $+3/8"$
 - When wall start is at nominal position from the building, the Altos wall can start at any angle between -45° and $+45^\circ$
 - When wall start is at minimum position ($1/2"$) from building the Altos wall can start at any angle between -38° and $+38^\circ$
- Distance between rotation point of wall start and building wall is $3/4"$
 - Distance between rotation point of wall start and centerline of the first vertical post is $2"$
 - Must be used with a Vertical Post package
 - Does **not** route electrics or communications from the building architecture
 - Finished in Clear Anodized or Painted

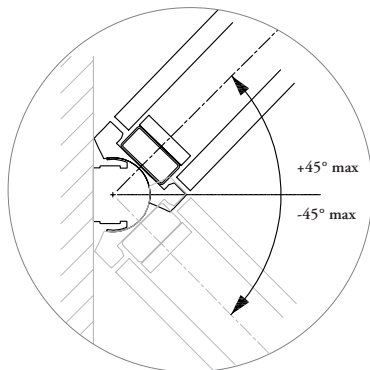

Nominal Adjustment

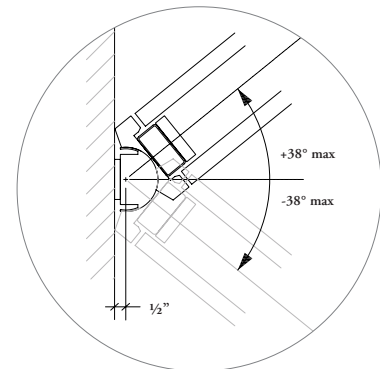
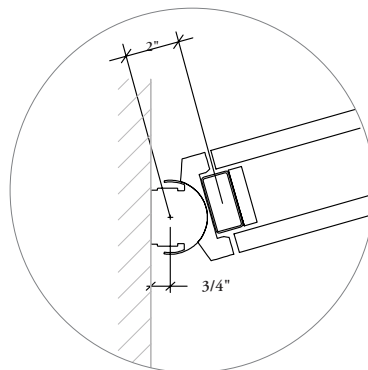

Minimum Adjustment

planning with wall starts & ends

The following should be considered when planning with wall starts and ends.

The adjustable wall start should be specified to match the elevation of the adjacent module.

The Adjustable Wall End and Wall Start attach to building architecture excluding glass and extends floor to ceiling

Cannot be used between wall modules or corner connections

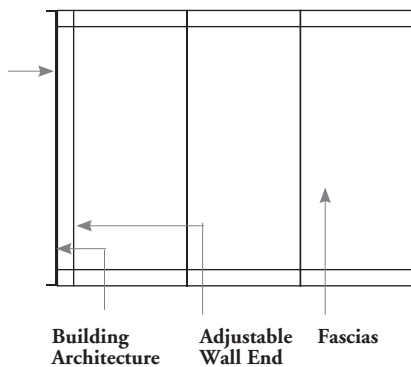

Worksurface Mounted on Module

Worksurfaces, mounted storage and accessories can be mounted on the wall module adjacent to the Adjustable Wall End or Wall Start

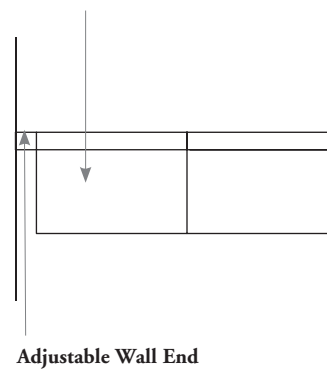

Adjustable Wall End

The Adjustable Wall End and Wall Start do **not** route electric or communications to adjacent walls

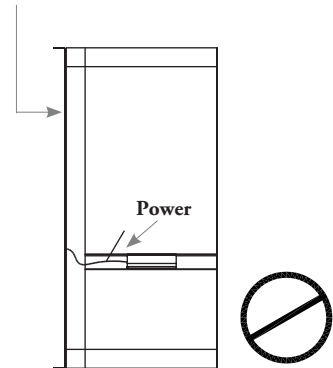

Full Height – Ceiling Height

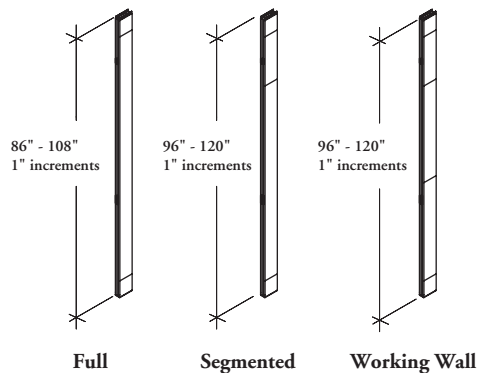

Adjustable Wall End (FKEG)

- Full-Height Ceiling Height (3" Adjustable Wall End) offers an adjustment range of +/- 1-1/2" and accommodates width variations of 1-1/2" - 4-1/2"
- Is planned as an additional 3" module at the end of a wall run
- No horizontal reveals are included

Adjustable Wall End (FKEF), (FKES), (FKEW)

- Offers an adjustment range of +/- 3" and accommodates width variations of 3" to 9" in anodized aluminum
- To maintain consistent horizontal reveal lines, the 6" wide Adjustable Wall End can be specified in Full, Segmented and Working Wall elevations
- In the Segmented and Working Wall Elevations, it is offered in each 1" increment from 96" up to 120" in height
- Adjustable Wall End is planned as an additional 6" module to complete a wall run and permits consistency of core width Fascias
- In the full elevation, the 6" Adjustable Wall End is offered in each 1" increment from 86" up to 120" in height

planning with module connections

The following should be considered when planning with module connections.

Electrics **cannot** be routed through the module connections.

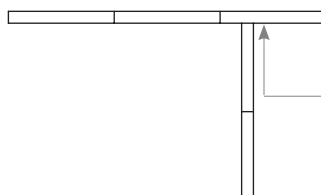

Spine Wall

- Module Connection adds 1-1/4" Creep – This added dimension comes from the connection interface
- There is no creep in spine wall

Spine Wall

Off-Module connections may not be connected to a Fascia on the spine wall that includes Smart Fascias – Accessory (FPMA), Whiteboard (FPMW), Tackable or Lay-In Module (FPLM), Power Communications Module (FPPC) or any Power/ Communication cut outs

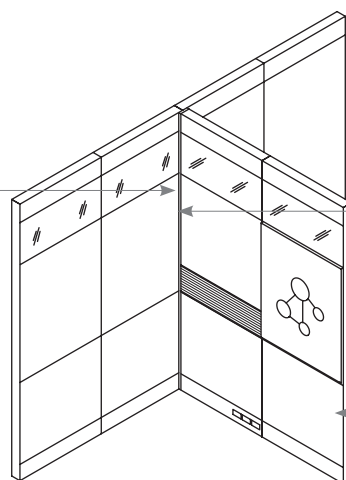

Attaching Module Connections to Double Glassed Fascia modules is not recommended as the connector will be visible

Perpendicular Wall

There are no restrictions for Fascias on the perpendicular wall

Hang-On Components

- The location of the Three-Way 180° Module Connection may restrict the location of hang on components (worksurfaces, mounted storage and accessories) on the spine wall
- Hang on components must be mounted on module so that they span between two vertical reveals
- For optimum planning, hang on components should be suspended from the perpendicular wall
- When mounting hang on components on the perpendicular wall, a 1-1/8" gap between the spine wall and the hang-on component results

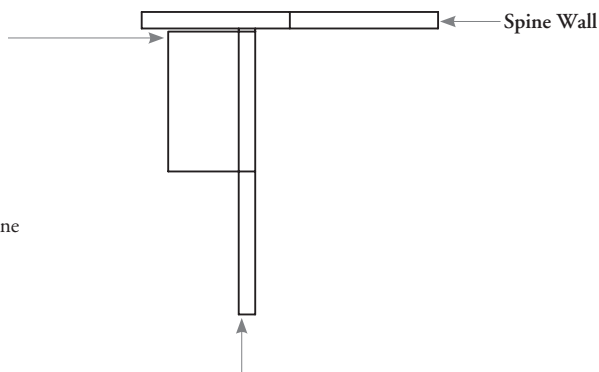

Perpendicular Wall

For optimum planning, hang on components should be suspended from the perpendicular wall

planning with module connections (continued)

Door type and location must be taken into consideration when planning with the Three-Way 180° Module Connection. The following chart shows where each door type can be used on the bisected spine wall.

There are no restrictions for doors located on the perpendicular wall.

Hinged Door
Hinged Glass Door
Pivot Door
Hinged Double Door

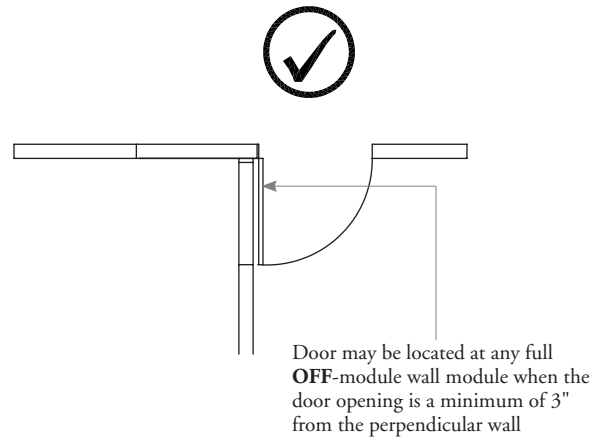
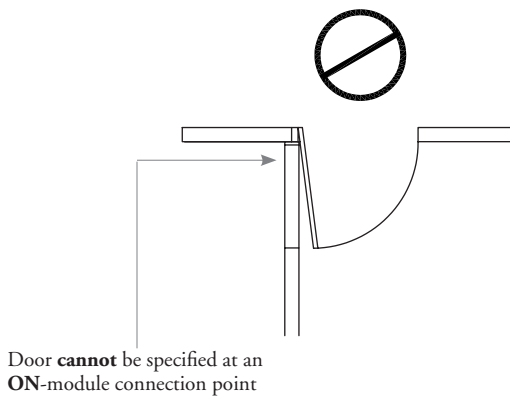

Barn Door
Solid Barn Door
Barn Door with Glass Insert

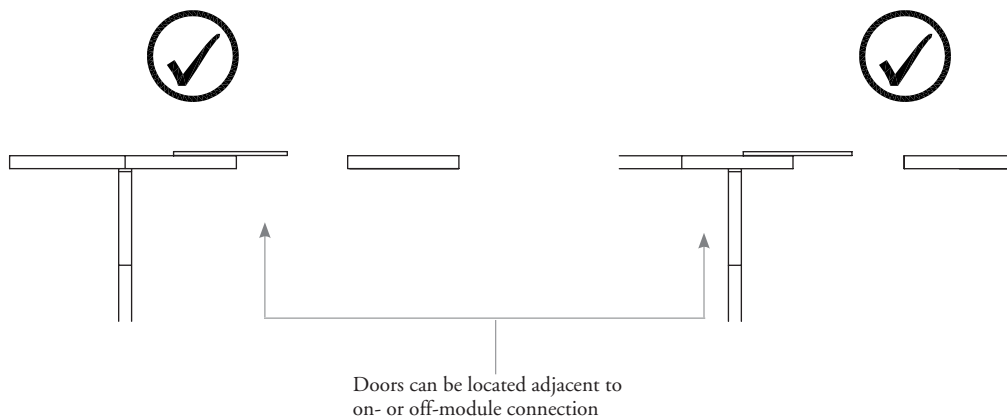

door frame basics

Several frame packages are available for door packages. See price pages for details of these products.

- It is not recommended to install a door adjacent to a Wall End (FKE), Wall Start (FKW/FPKW) or Filler Panel (FPF)
- If Fascias are required to complete assembly they must be specified separately

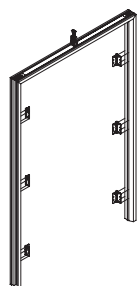

Double Door Frame – Full Height (FKTF/FPFDS)

Required for the Full Height Hinged Double Door (FDD/FPDD)

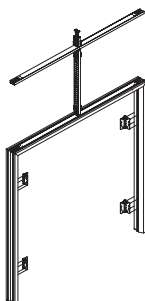

Double Door Transom & Frame – Segmented Height (FKTS)

Required for the Segmented Double Door (FDD/FPDD)

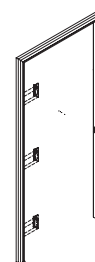

Door Frame Kit for Full or Segmented Height (FKD) and Door Frame Kit for Full Height (FPFJS/FPFHS)

Required for the Full or Segmented Height Hinged Door (FDH/FPDH) or Glass Door (FDJ/FPDJ)

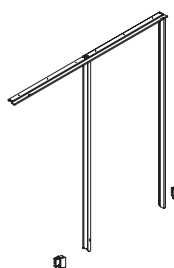

Portrait Barn Door Jamb Kit for Full-Height Glass Door (FPBGFJ) and Portrait Barn Door Rail Kit for Full-Height Door (FPBFR)

Required for the Full Height Glass Barn Door (FDC)

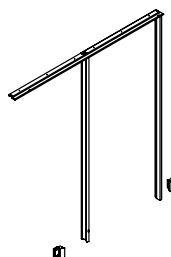

Portrait Barn Door Rail Kit for Full-Height Door (FPBFR) and Portrait Barn Door Jamb Kit for Full-Height Solid Door (FPBSFJ)

Required for the Full Height Solid Barn Door (FDS/FDI)

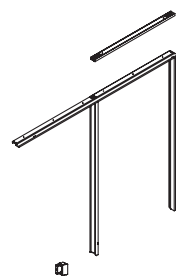

Portrait Barn Door Jamb Kit for Segmented-Height Glass Door (FPBGSJ) and Portrait Barn Door Rail Kit for Segmented-Height Door (FPBSR)

Required for the Segmented Glass Barn Door (FDC)

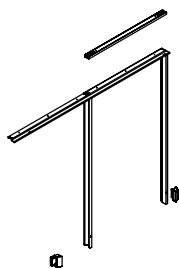

Portrait Barn Door Rail Kit for Segmented-Height Door (FPBSR) and Portrait Barn Door Jamb Kit for Segmented-Height Solid Door (FPBSJ)

Required for the Full Height Solid Barn Door (FDS/FDI)

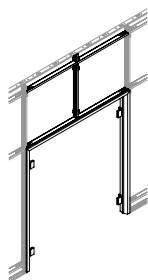

Hinged Glass Double Door Transom & Frame Package – Segmented Height (FKTES)

Required for the Segmented Hinged Glass Double Door (FDE/FPDE)

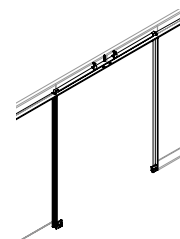

Portrait Double Barn Door Rail Kit for Full-Height Door (FPLGFR) and Portrait Double Barn Door Jamb Kit for Full-Height Glass Door (FPLGFJ)

Required for the Full Height Double Glass Barn Doors (FDL)

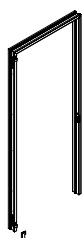

Glass Pivot Door Solid Frame Kit for Full or Segmented Height (FKPSZ) and Glass Pivot Door Solid Frame Kit for Full Height (FPFPS)

Required for the Full or Segmented Height Framed Glass Pivot Door (FDPZ/FPDPZ)

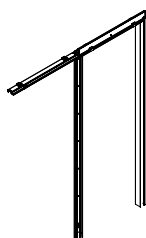

Portrait Barn Door Rail Kit for Full Height Door – Low Profile (FPUGFR) and Portrait Barn Door Jamb Kit for Full Height Glass Door – Low Profile (FPUGFJ)

Required for the Full Height Glass Barn Door (FDCZ)

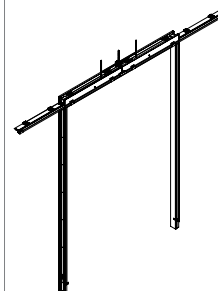

Portrait Double Barn Door Rail Kit for Full-Height Door – Low Profile (FPVGFR) and Portrait Double Barn Door Jamb Kit for Full-Height Glass Door – Low Profile (FPVGFJ)

Required for the Full Height Double Glass Barn Door (FDLZ)

planning with double barn door frames

The following rules should be considered when planning with the Double Barn Door frame.

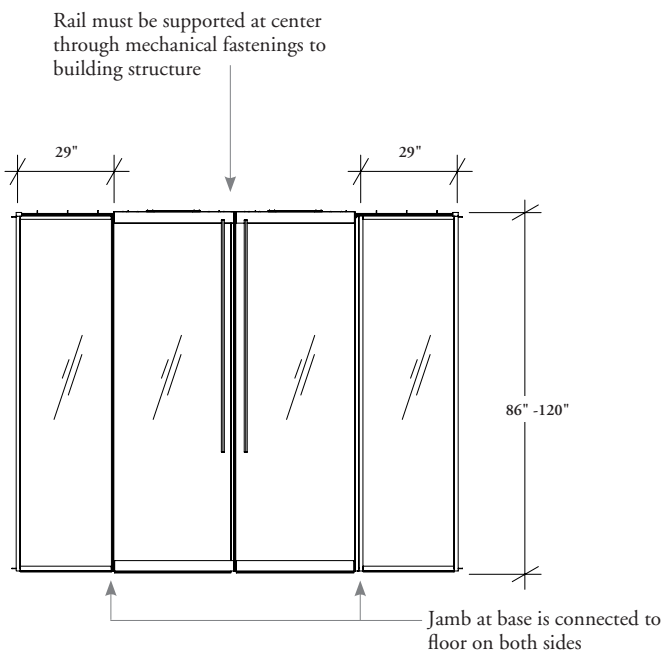
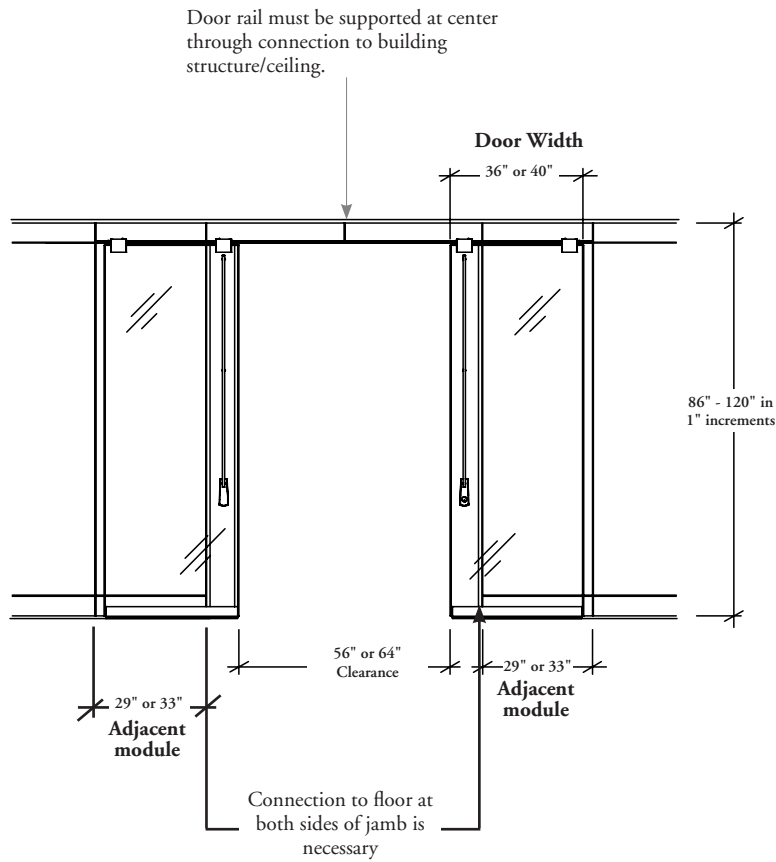

fascia reveal inserts

An optional Black Vertical Reveal Cover Kit (FKJC) is available when planning with Platinum or Very White wall gaskets. The following outlines the features:

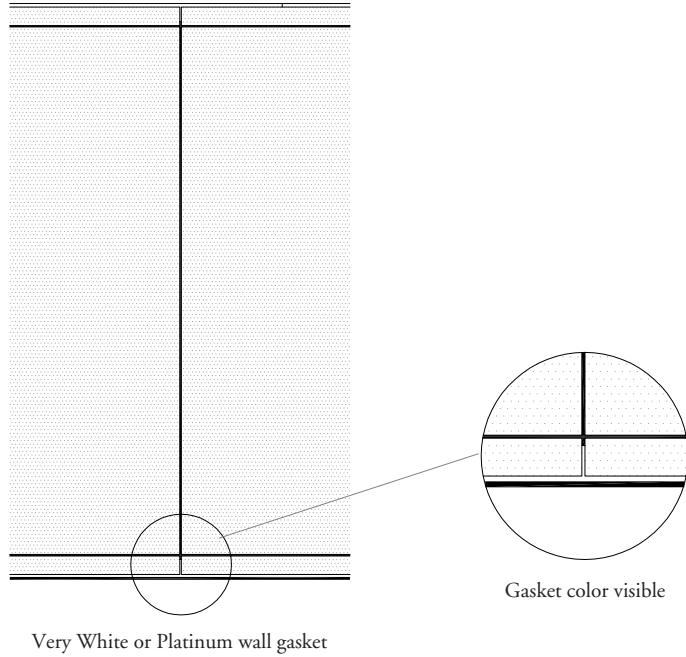

Vertical seams are Black and visible unless finished with a reveal insert.

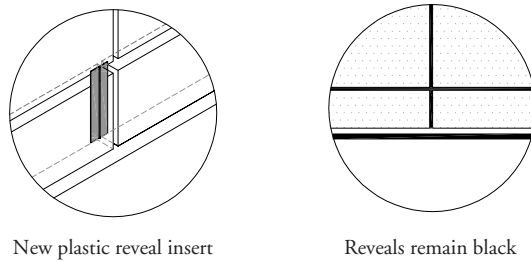

The Vertical Reveal Cover Kit is black to match reveal lines.

frame kit component basics

Altos frame kits come with all necessary connection components however, certain components can also be purchased individually if required. See Price & Product Guide for details of these products.

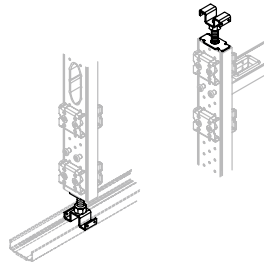

Base Levelers (FBB)

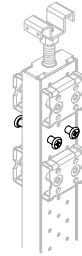

Horizontal Shoulder Screw (FBN)

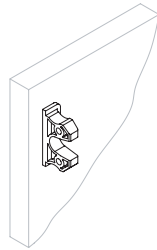

Fascia Connector - Male (FBFM)

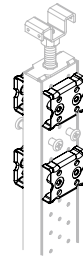

Fascia Connector - Female (FBFF)

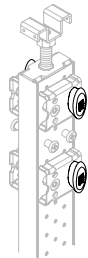

Fascia Lock (FKL)

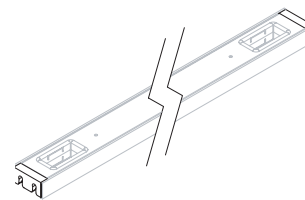

Horizontal End Cap (FBE)

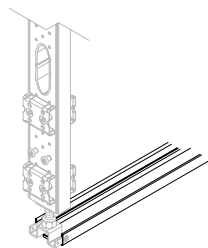

Base Channel - Modular (FPKB)

portrait – tek pier

portrait – tek pier

WHAT IS TEK PIER	118
FRAME ASSEMBLY BASICS	120
PLANNING WITH FRAME ASSEMBLY	121
TEK PIER FASCIA BASICS	122
PLANNING WITH TEK PIER FASCIAS	123
TEK PIER ASSEMBLY BASICS	125
PLANNING WITH TEK PIER ASSEMBLY	126
TEK PIER WORKSURFACE BASICS	131
PLANNING WITH TEK PIER WORKSURFACES	132

what is tek pier

Tek Pier is a demountable wall-integrated, height-adjustable, and technology-supported workspace. Designed to enable technology engagement by articulating a large monitor for individual or group use in private office and meeting room environments, this innovative solution maintains a minimal profile while providing an ergonomic collaboration experience.

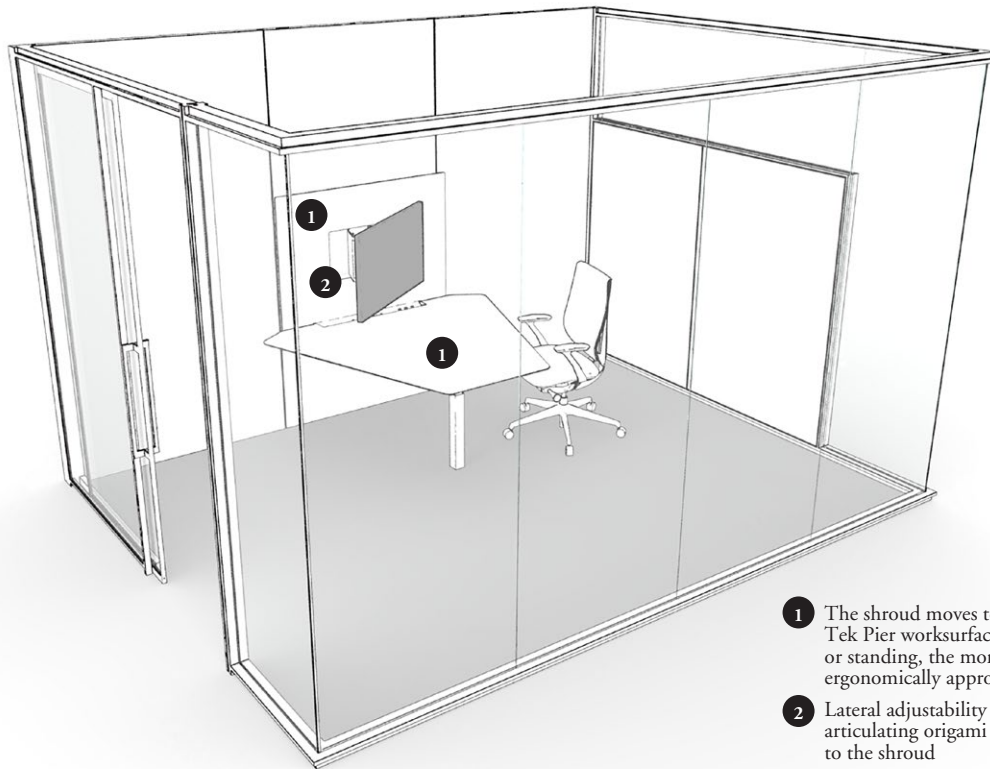

- 1 The shroud moves together with the Tek Pier worksurface so whether sitting or standing, the monitor is always at an ergonomically appropriate viewing height
- 2 Lateral adjustability is provided by the articulating origami arm which is mounted to the shroud

- A Tek Pier station consists of a frame assembly, fascias, Tek Pier assembly and a worksurface which all must be specified individually
- Tek Pier uses Altos Portrait Fascia elevations only
- Tek Pier is **not** available next to Altos Landscape

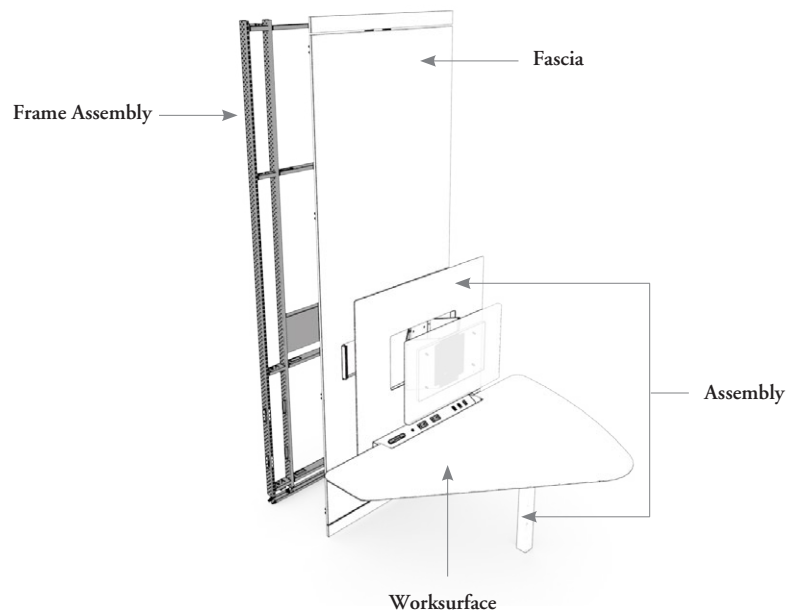

what is tek pier (continued)

Two sizes of the Tek Pier assembly are available:

- Tek Pier Assembly 1
- Tek Pier Assembly 2

Three worksurface shapes are available:

- Spade Top Worksurface
- Pie Top Worksurface
- Wedge Top Worksurface

Three configurations can be achieved depending on the worksurface shape and the Tek Pier assembly specified:

tek pier assembly 1

Spade Top

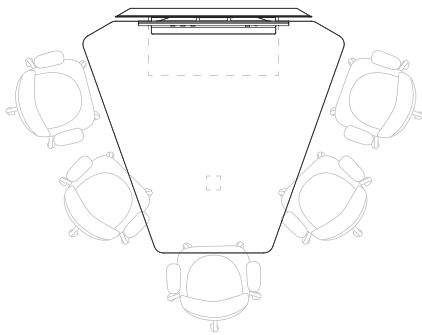
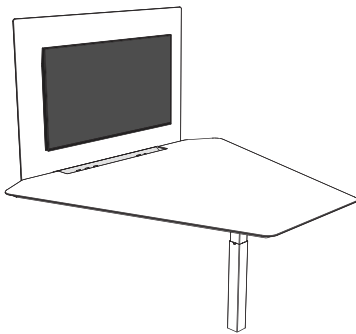

- Up to five collaborators
- Symmetrical
- Sit Stand Range 24" - 43"
- Ideal for meeting rooms and collaboration

tek pier assembly 2

Pie Top

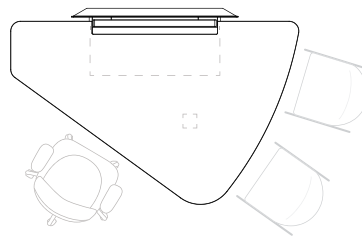
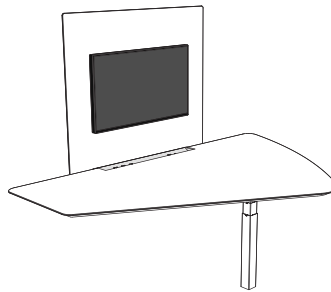

- Up to three collaborators, one primary and two guests
- Left and right handed versions
- Sit Stand Range 24" - 43"
- Ideal for small enclaves and private offices

tek pier assembly 2

Wedge Top

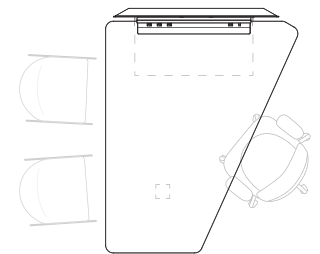
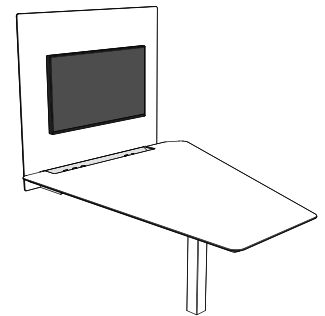

- Up to three collaborators, one primary and two guests
- Left and right handed versions
- Sit Stand Range 24" - 43"
- Ideal for small enclaves and private offices

origami arm

The origami arm has six pivot points allowing the user to adjust the monitor in several locations.



Flat on wall

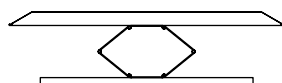

Extended off wall

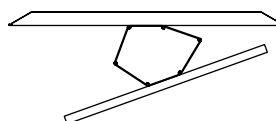

Angled right

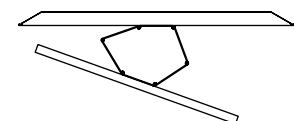

Angled left

frame assembly basics

The Frame Assembly for Tek Pier is an Altos frame and consists of several vertical and horizontal channels allowing for Tek Pier technology and supports to be concealed within the frame.

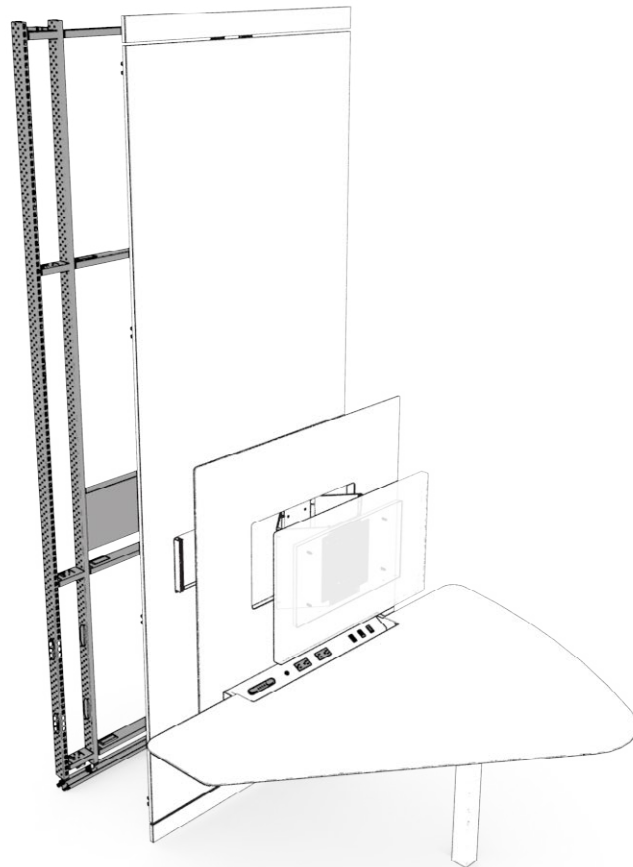

Single Sided Shown

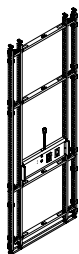

Frame Assembly for Tek Pier (FKTKP)

- Available heights include 94"-120" in 1" increments
- Available widths are 42" and 48"
- Available single sided or double sided
- Wiring system is 4 Wire (Modular and Chicago) hardware
- Available with Circuit Type 1 and Circuit Type 2 for Modular only
- Base and ceiling fascia heights are 4" and 6" high
- Fascias must be ordered separately and are available only as kits
 - Monolithic
 - Segmented Monolithic
 - Full
 - Segmented

planning with frame assembly

Tek Pier is available with a modular hardwired or Chicago Style electrics system. Electrics are routed through either a ceiling or base feed connection to the building.

capacity restriction

- A Single 15 Amp Circuit can power up to two Tek Piers of any standard configuration
- Wiring system for junction box is 4 wire (modular hardwired and Chicago) hardware
- Conduit length for junction box is restricted to 12' long for modular hardwired and 20' long for Chicago electrics
- Tek Pier modular system is used with Altos modular electrics system with 4-wire wiring system

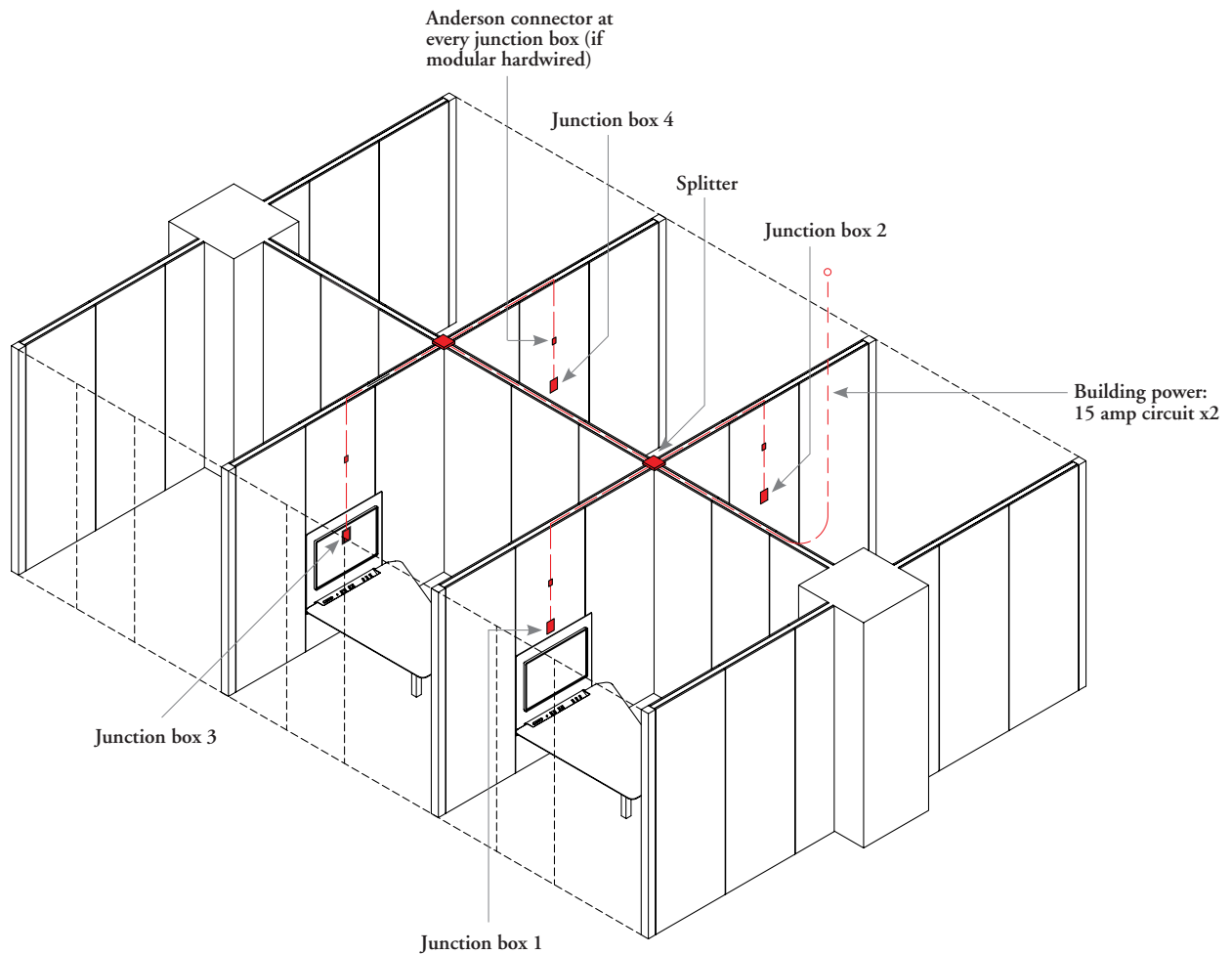

tek pier fascia basics

Tek Pier Fascias are used in combination with the frame assembly to accommodate supports and provide accurate cut out locations for the Tek Pier assembly.

- Base and ceiling fascia heights are 4" or 6"
- Available 42" and 48" wide
- For determining the correct fascia height, please refer to Altos Fascia section, Specifying Fascia Heights page.
- Tek Pier cut out for height-adjustable mechanism is available on Level 1 Fascia
- Tek Pier uses Altos Portrait Fascia elevations only

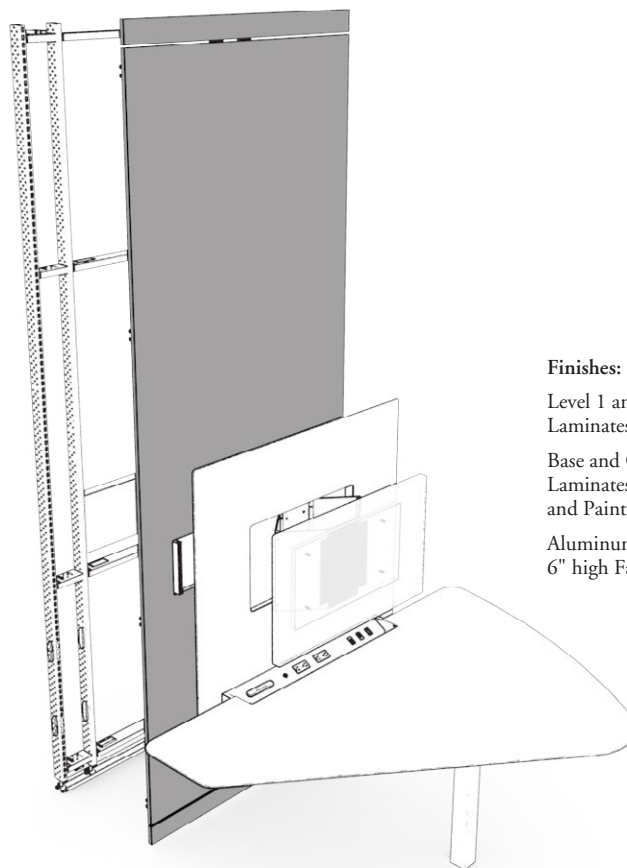

Finishes:

Level 1 and 2 Fascia finishes include Fascia Laminates and Flintwood Stains

Base and Ceiling Fascia finishes include Fascia Laminates, Flintwood Stains, Clear Anodized and Painted

Aluminum finish selection is not available on 6" high Fascias

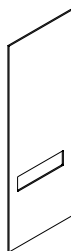

Monolithic Fascia (FFMTKP)

Fascia is available in heights of 94" - 120" in 1" increments.

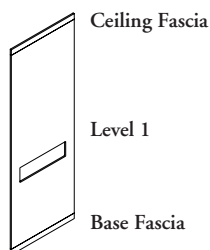

Full Fascia Kit (FFFTKP)

Level 1 Fascia is available 84" - 112" in 1" increments.

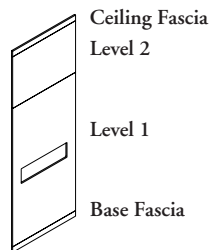

Segmented Fascia Kit (FFSTKP)

- Level 1 Fascia is available 78" and 80" high
- Level 2 Fascia is available 6" - 32" in 1" increments

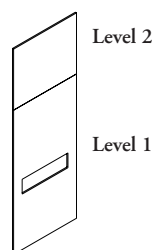

Segmented Monolithic Fascia Kit (FFSMTKP)

- Level 1 Fascia is available 84" high
- Level 2 Fascia is available 10" - 36" in 1" increments



4" Base and Ceiling Fascia Kit for Tek Pier (Opposite Side) (FFCBTKP)

Available 42" and 48" wide.

planning with tek pier fascias

Tek Pier fascias are used to create the face of the frame assembly and can be configured into four wall types depending on the fascia selection.

The fascia width is determined by the shroud and frame assembly width specified. Both left and right side fascia must be specified with standard Altos fascias.

tek pier assembly 1

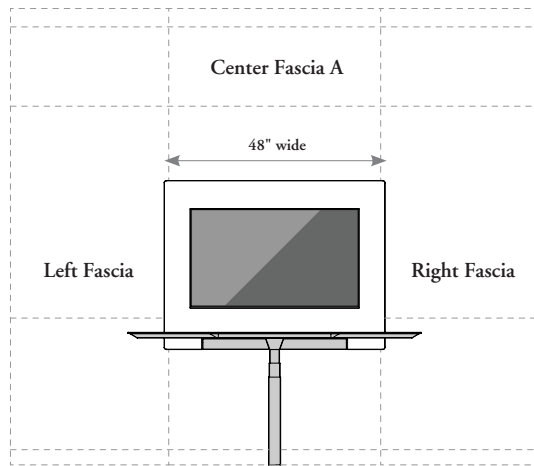

When a 48" wide fascia is specified, it must be specified on a 48" wide Frame Assembly for Tek Pier (FKTKP) and also with Tek Pier Assembly 1 (TKP1).

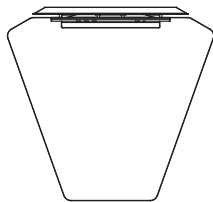

Spade Top Worksurface

When a Spade Top Worksurface (TKPA) (see worksurfaces) is required, a 48" wide Frame Assembly for Tek Pier (FKTKP) and Tek Pier Assembly 1 (TKP1) must be specified.

tek pier assembly 2

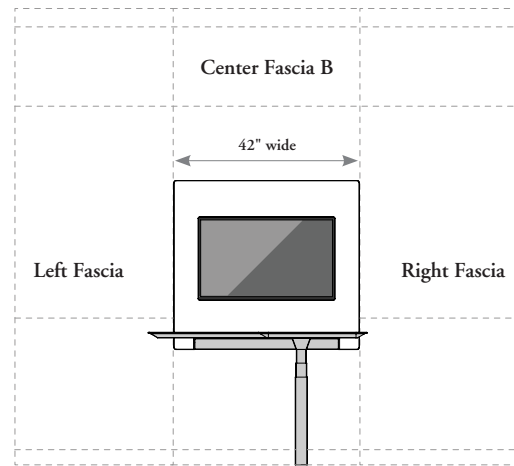

When a 42" wide fascia is specified, it must be specified on a 42" wide Frame Assembly for Tek Pier (FKTKP) and also with Tek Pier Assembly 2 (TKP2).

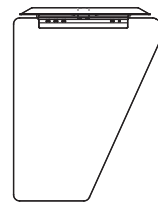

Wedge Top Worksurface

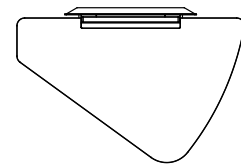

Pie Top Worksurface

When a Wedge Top Worksurface (TKPC) or a Pie Top Worksurface (TKPB) (see worksurfaces) is required, a 42" wide Frame Assembly for Tek Pier (FKTKP) and Tek Pier Assembly 2 (TKP2) must be specified.

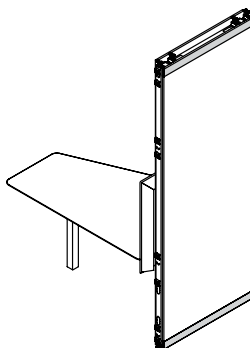

When a single-sided application is specified, the opposite side to the Tek Pier, workstation does not require Tek Pier Fascias, standard Altos fascias can be used. However, if a 4" Base and Ceiling Fascia Kit is desired on the opposite side, the dedicated Tek Pier 4" Base and Ceiling Fascia Kit (FFCBTKP) must be used.

planning with tek pier fascias (continued)

In a double-sided application, it is recommended that both the left and right side fascias are the same width so both sides are symmetrical.

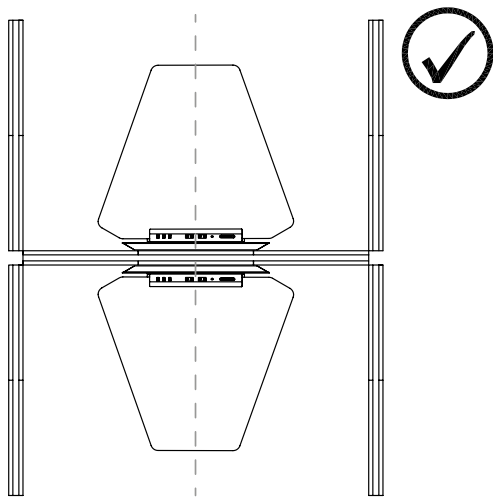

Centered

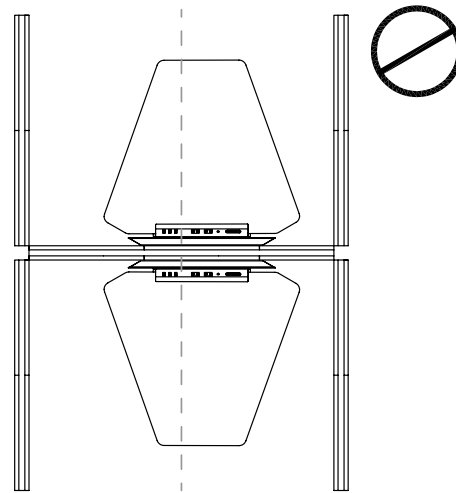

Right Justified (shown)

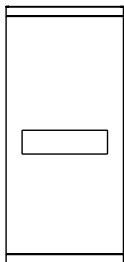

All center Tek Pier fascias come with cut outs to accommodate Assembly Kits.

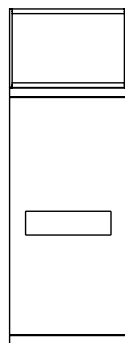

Clerestory is not available on Tek Pier frames.

grain direction

The illustration below demonstrates the grain direction for all Veneers and Flintwood.

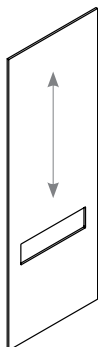

tek pier assembly basics

The Tek Pier assembly includes the actuators, e-chain, shroud, origami arm, shroud pan, Tek Pier electrics beam and height-adjustable leg.

Electrical orientation can be specified left or right.

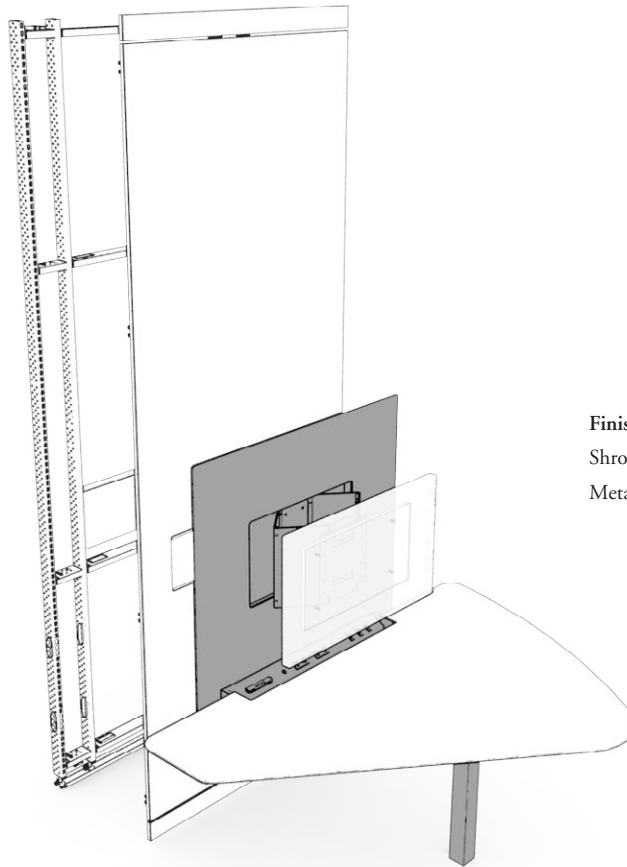

Finishes:

Shroud surface finish is Glacier White solid surface

Metal finishes include Very White and Platinum paint

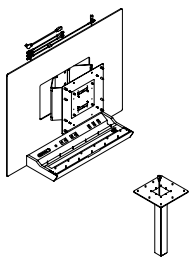

Tek Pier Assembly 1 (TKP1)

- Accommodates Spade Top Worksurface (TKPA)
- Must be specified on a 48" wide Frame Assembly for Tek Pier (FKTKP)
- Recommended monitor is 39" - 46" and is restricted to 35 lbs

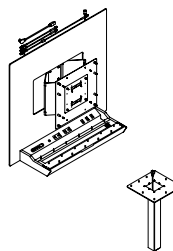

Tek Pier Assembly 2 (TKP2)

- Accommodates Wedge Top Worksurface (TKPC) and Pie Top Worksurface (TKPB)
- Must be specified on a 42" wide Frame Assembly for Tek Pier (FKTKP)
- Recommended monitor is 30" - 38" and is restricted to 35 lbs

planning with tek pier assembly

The Tek Pier assembly is made up of several parts to allow for a sit-stand workstation.

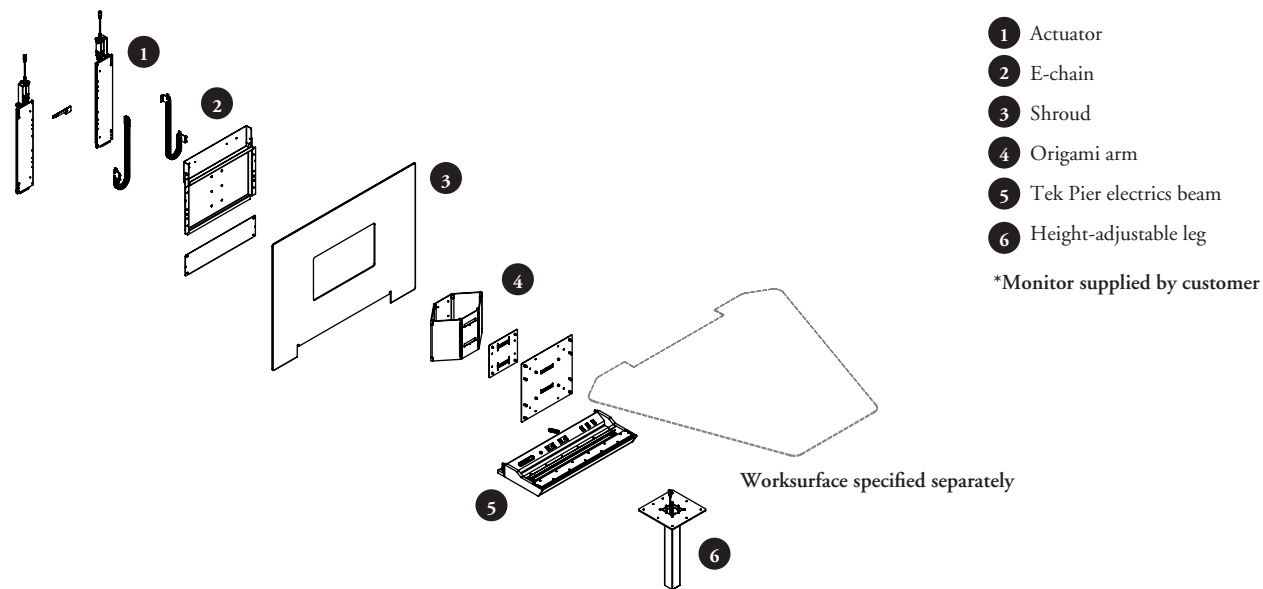

origami arm

The origami arm has six pivot points allowing the user to adjust the monitor in several locations.

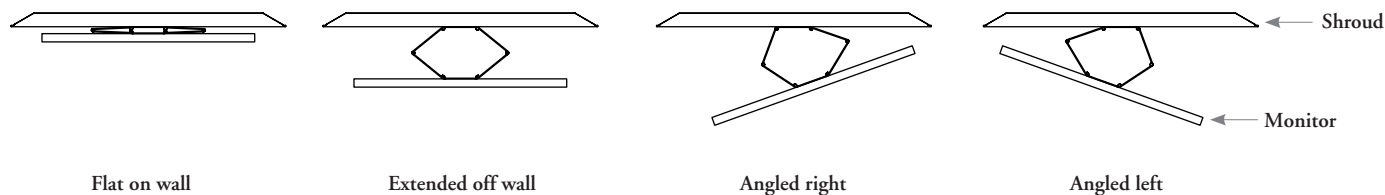

The Tek Pier assembly components **cannot** be mounted directly to drywall. Custom applications can be accommodated to allow the Frame Assembly for Tek Pier to be mounted on Altos wall between two drywall partitions or in front of a straight run of drywall. Please contact your Teknion Customer Service Representative for more information.

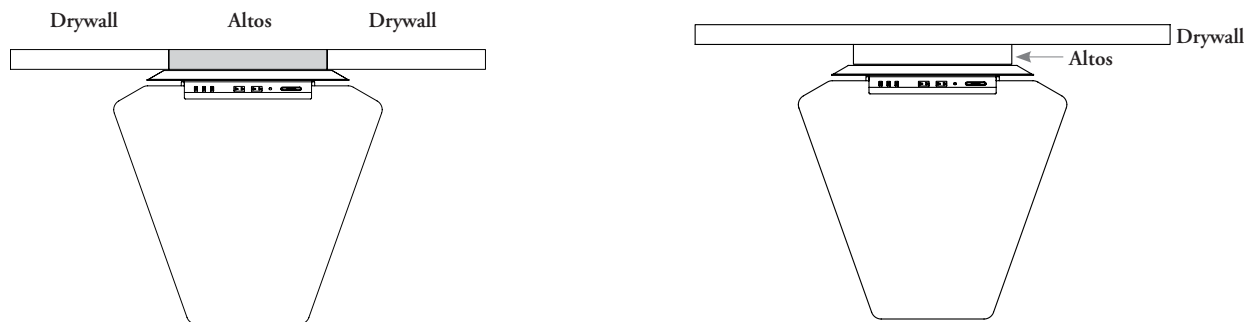

planning with tek pier assembly (continued)

height-adjustable leg

The Height-adjustment range is 24" - 43" high to allow for lounge, sit and standing heights. The integrated height-adjustable mechanism is designed with anti-collision detection for safety considerations.

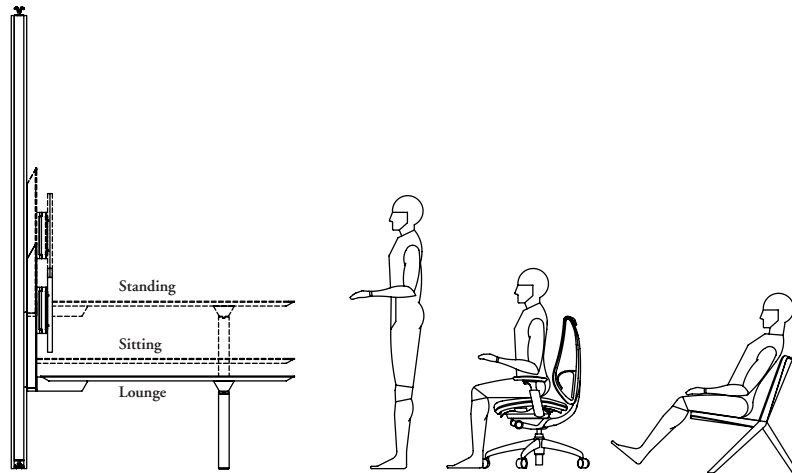

electrics beam

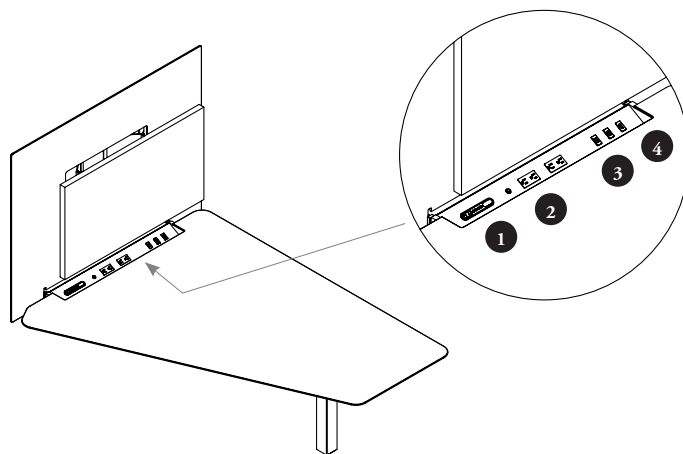

Left handed Wedge Top Worksurface (TKPC) and left handed electrics beam shown

The electrics beam consists of:

- 1 An easily accessible sit-stand switch location with memory and digital readout
- 2 Four plastic Grey power plug-in locations that are tamper resistant for safety purposes with circuit breaker button
- 3 Two plastic Grey USB ports oriented for powering and charging devices
- 4 One plastic Grey HDMI video connection to the screen

Electrics beams are handed and determined by the location of the sit-stand switch in relation to the user.



Left handed electrics beam corresponds with left-handed and symmetrical workspaces

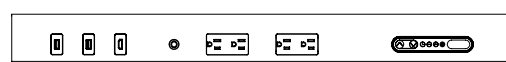

Right-handed electrics beam corresponds with right-handed and symmetrical workspaces

planning with tek pier assembly (continued)

wire management

Tek Pier offers integrated cable routing, allowing for height-adjustability, technology connectivity and optional wireless control downloadable application.

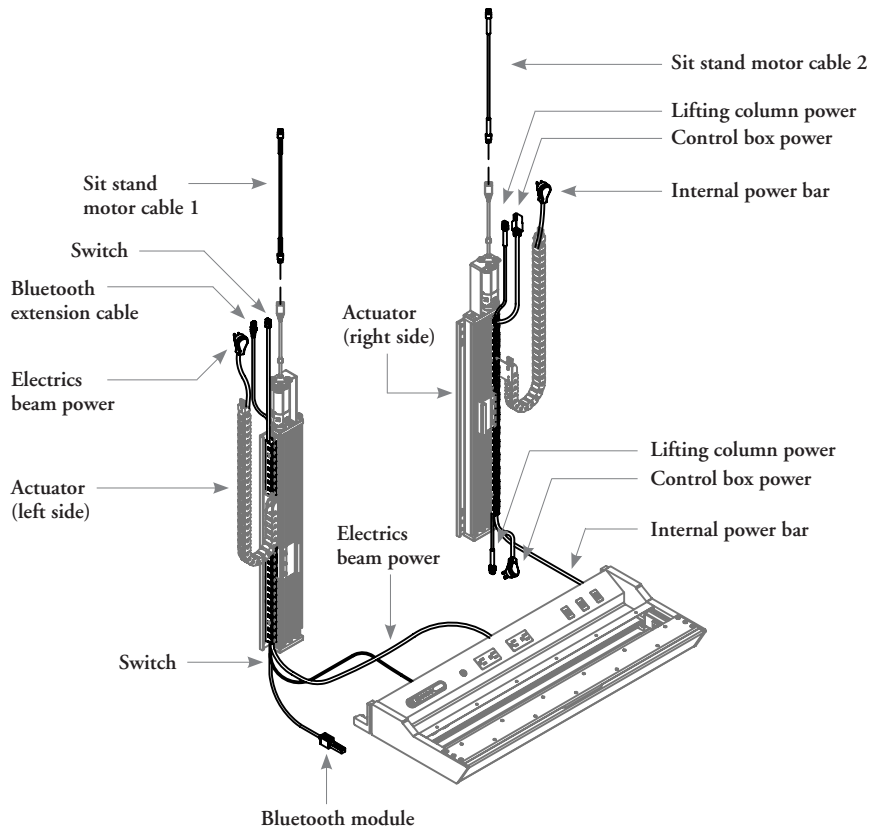
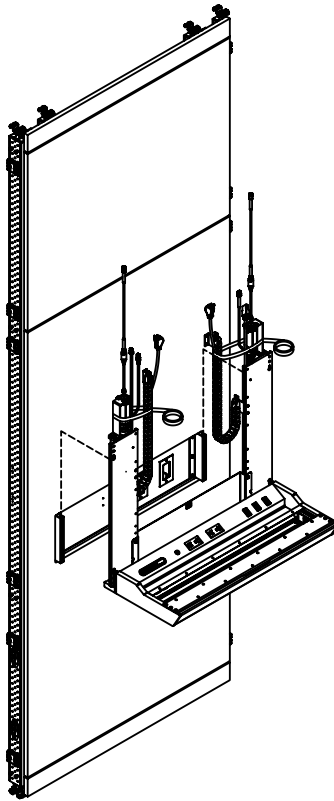

planning with tek pier assembly (continued)

specifying the correct monitor type

When specifying a monitor for Tek Pier, it is important to select a monitor with an HDMI cable that is parallel to the back of the monitor to avoid interference when the monitor is in a pushed back location. The Assembly 1 (TKP1) is recommended for use with 39" - 46" monitor size. Assembly 2 (TKP2) is recommended for use with 30" - 38" monitor size. Monitors **cannot** weigh more than 35 lbs .

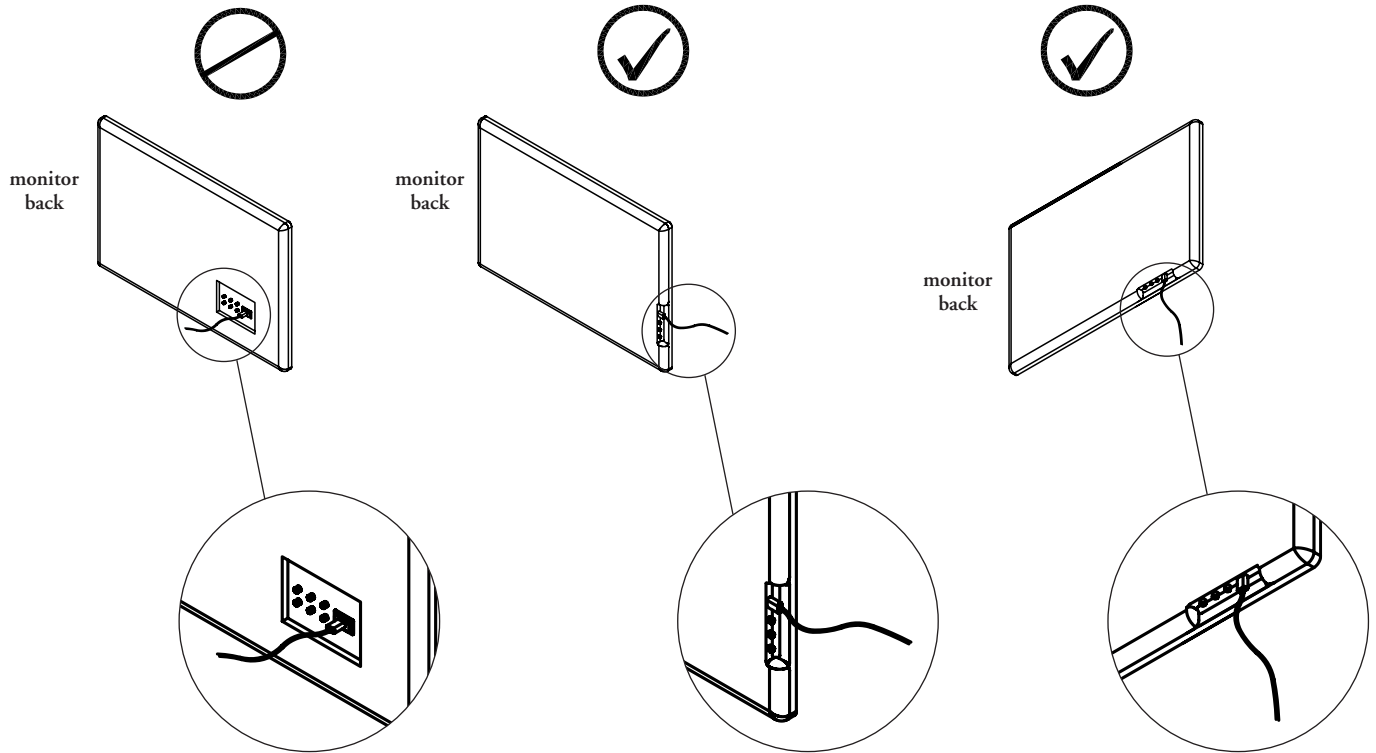

When specifying a monitor for Tek Pier, it is important to select a monitor with a centered VESA pattern to maximize adjustability.

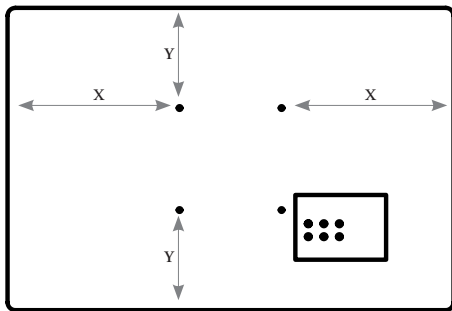

VESA pattern is centered top to bottom and side to side

planning with tek pier assembly (continued)

The monitor supplied by the customer cannot exceed 35 lbs and must be equipped with an HDMI video connection outlet. The universal VESA plate for the origami arm is available in two sizes to accommodate most monitors.

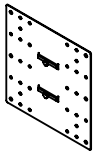

Large Plate

- Generally for larger screens based on monitor specification by the customer
- Accommodates 200 x 200mm, 300 x 200mm, 300 x 300mm, 400 x 200mm and 400 x 400mm VESA patterns with vertical monitor adjustment in certain patterns



Small Plate

- Generally for smaller screens, based on monitor specification by the customer
- Accommodates 100 x 100mm and 200 x 200mm VESA patterns with vertical monitor adjustment

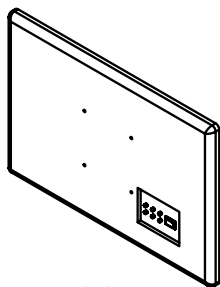

Back of monitor

VESA pattern hole

- Select a monitor with an HDMI port to connect to the electric beam
- Maximum monitor weight is 35 lbs

Back of monitor

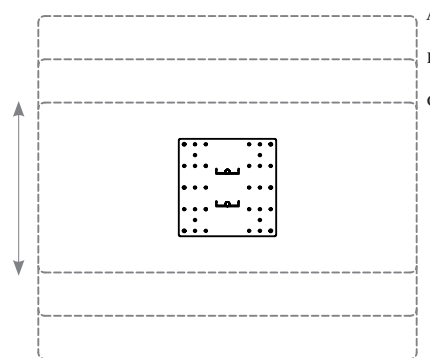

Back of monitor

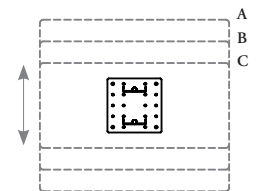

- VESA plate with vertical adjustment
- Vertical adjustment is available with 100 x 100mm, 200 x 200mm, 300 x 300mm, 400 x 200mm patterns

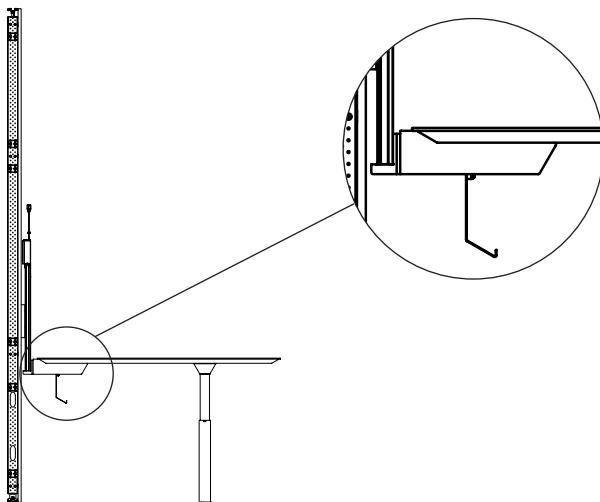

Tek Pier provides an electric access hatch below the worksurface. This space is available for technology storage provided by the customer and houses the optional bluetooth wireless modules.

tek pier worksurface basics

Tek Pier worksurfaces are available in three shapes: Spade, Pie and Wedge Tops to match Tek Pier assembly sizes.

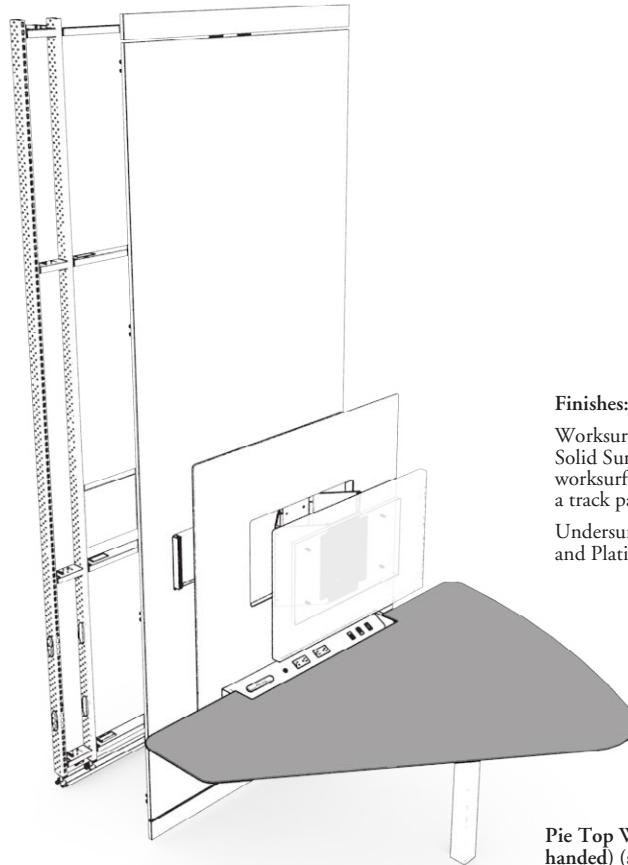

Finishes:

Worksurface top finish is Glacier White Solid Surface (when using a mouse on worksurfaces, it is recommended to use on a track pad to maximize usability).

Undersurface finishes include Very White and Platinum Paint

Pie Top Worksurface (left-handed) (shown)

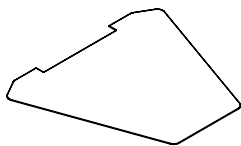

Spade Top Worksurface (TKPA)

- Worksurface depth is 59"
- Worksurface length is 67-1/2"
- Must be used with Tek Pier Assembly 1 (TKP1)
- Symmetrical

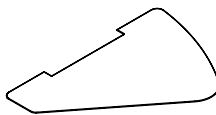

Pie Top Worksurface (TKPB)

- Worksurface depth is 46"
- Worksurface length is 66-1/2"
- Is left or right-handed
- Must be used with Tek Pier Assembly 2 (TKP2)

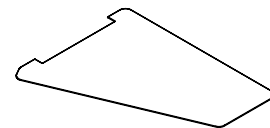

Wedge Top Worksurface (TKPC)

- Worksurface depth is 66"
- Worksurface length is 50"
- Is left or right-handed
- Must be used with Tek Pier Assembly 2 (TKP2)

planning with tek pier worksurfaces

The following outlines the features of Tek Pier worksurfaces.

Tek Pier worksurfaces are designed to be used in various applications.

Spade Top Worksurface

- Ideal for meetings and collaboration
- The origami monitor mount recedes into shroud to allow for maximum collaboration
- Recommended for use in a medium sized room (10' x 12')

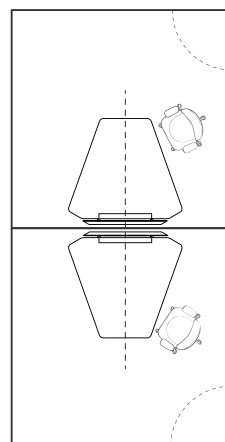
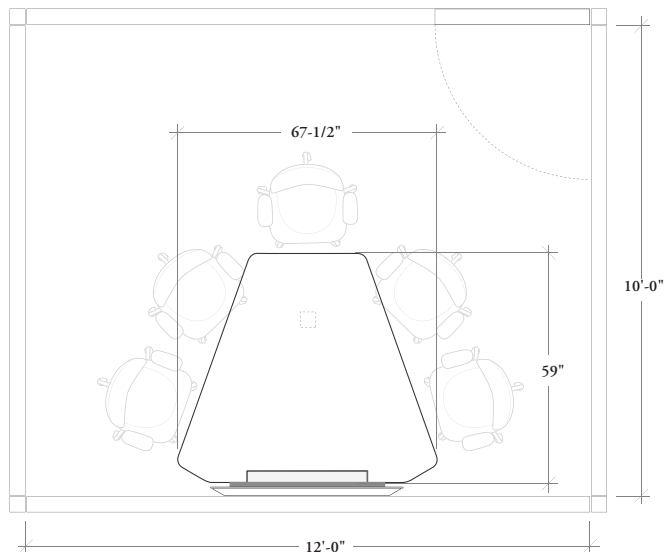

The Spade Top Worksurface is not handed

Pie Top Worksurface

- Ideal for small enclaves or private offices
- Allows for a single user or user with up to two guests
- Recommended for use in a small sized room (minimum 7' x 10'), justified to the corner

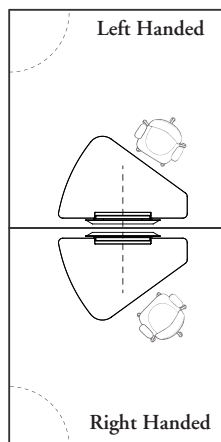
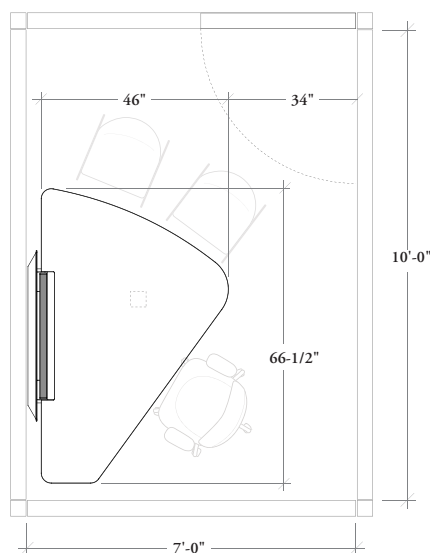

The Pie Top worksurface is handed and is determined by the location of primary user

planning with tek pier worksurfaces (continued)

Wedge Top Worksurface

- Ideal for small enclaves or private offices
- Allows for a single user or user with up to two guests
- Recommended for use in a small office (10' x 10')

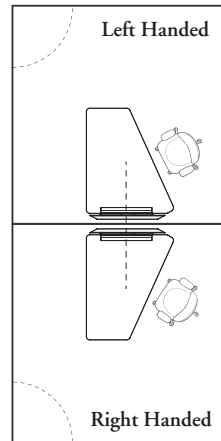
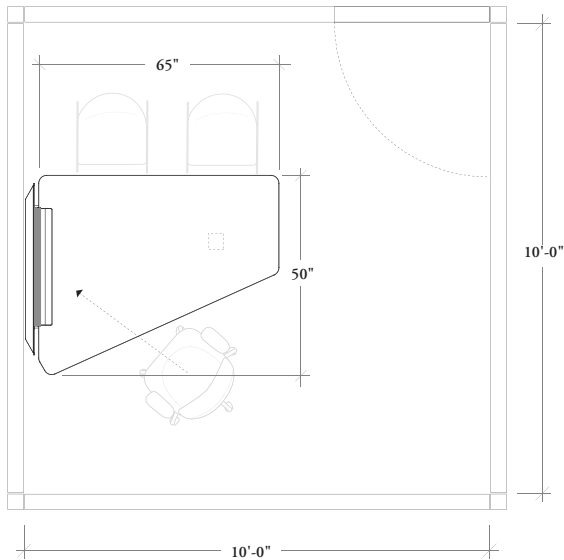

The Wedge Worksurface is handed and is determined by the location of primary user

planning with tek pier worksurfaces (continued)

Configurations

When planning double-sided configurations both sides must have the same Tek Pier assembly.

Back to back worksurfaces must align with each other to accommodate supports. Both sides must have the same Tek Pier assembly. Wedge and Pie Worksurfaces use the same Tek Pier assembly and can be installed back to back.

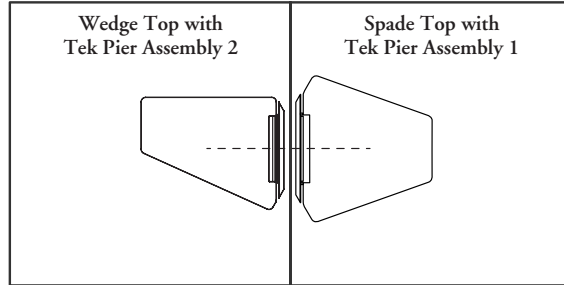
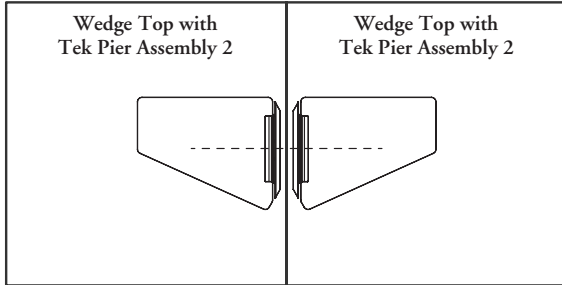

Different Tek Pier assembly

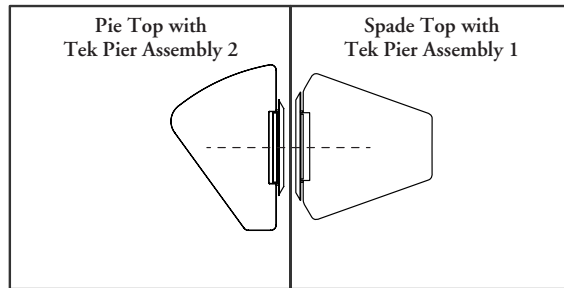
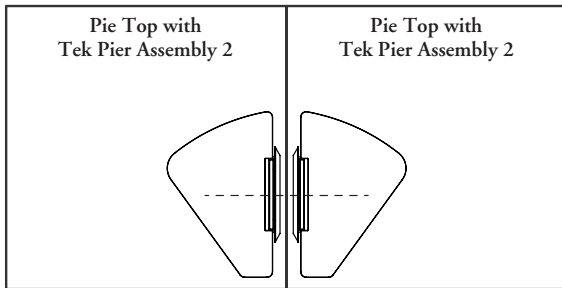

Different Tek Pier assembly

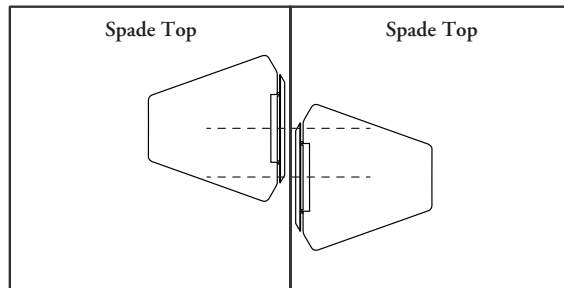
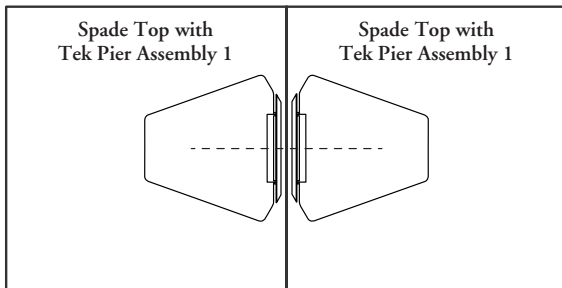

Not aligned

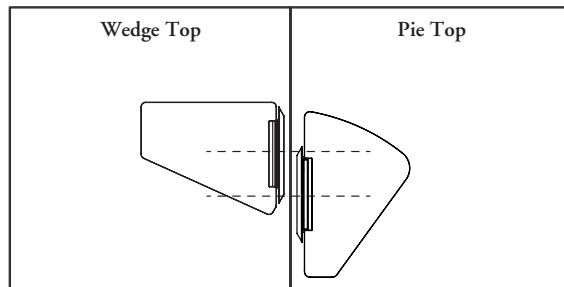
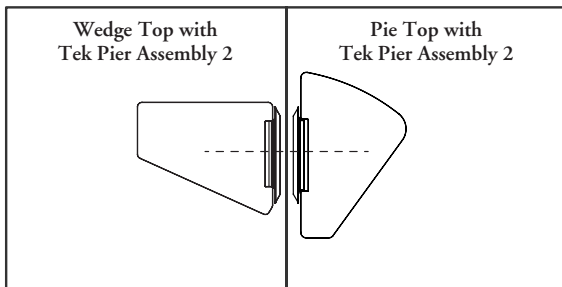

Not aligned

portrait – clerestory -
optos profile

portrait – clerestory - optos profile

CLERESTORY BASICS 139

CLERESTORY PLANNING RULES 142

An Optos clerestory module consists of Optos glass above 84" and Altos Portrait below.

- Optos clerestory is **not** available above Altos Landscape
- Tempered Glass is only available in Standard Clear
- Textured glass is not available
- For information on articulating corner connections with Optos, refer to the Corners & Connections - 10mm & 12mm section in the Optos Price Guide
- If a finished wall end is required for an Optos Clerestory module wall, use the Optos (FZFF/FXFF)
- If a filler panel is required with an Optos Clerestory wall, use the Optos Adjustable Wall Start (FZWS/FXWS)

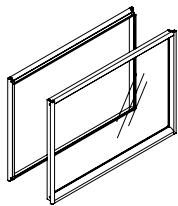
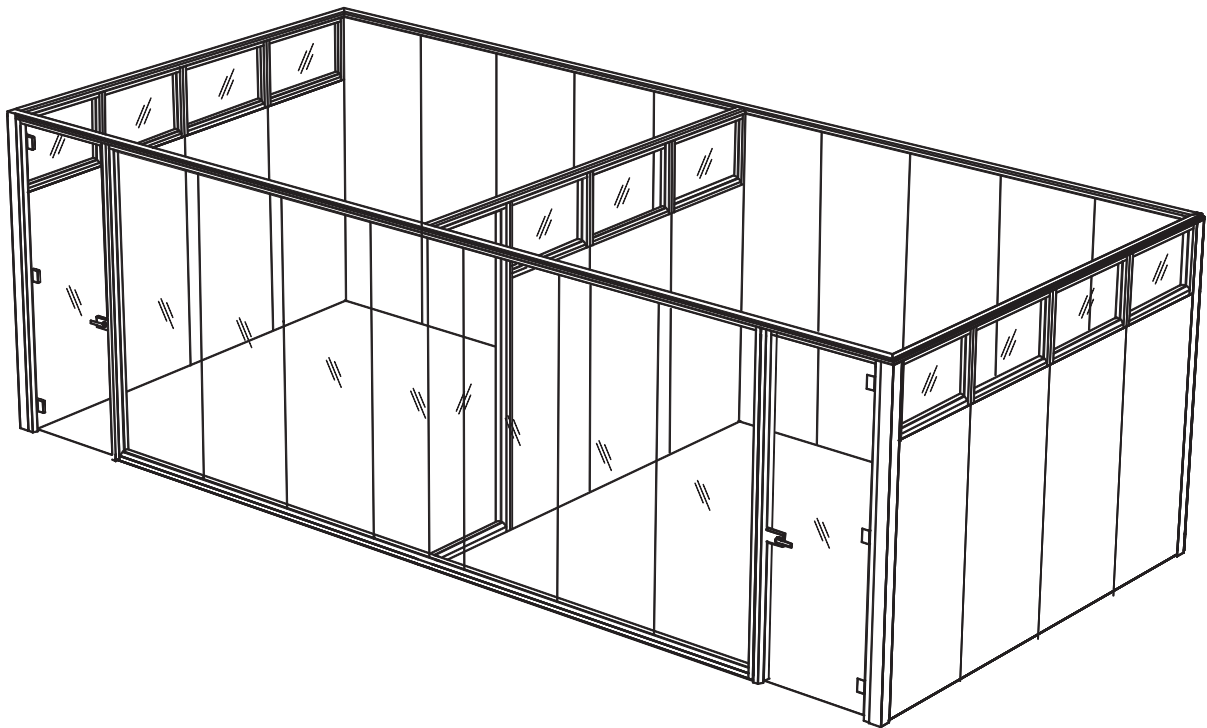

Optos Clerestory Glass Module (FZCG/FXCG)

- Is a framed, single centered glass fascia
- Glass is 6mm and available in tempered or laminated
- Tempered glass is available in Clear
- Laminated glass is available in Clear, Frost and Vanceva Specialty Glass
- Frame is available in a Clear Anodized or Painted finish
- Available in 1" height increments of 10"-36" and in 1" width increments of 12"-48"

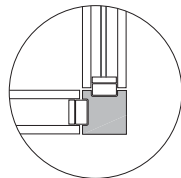

Optos Clerestory Two-Way 90° Corner Connection with Altos (FZCCA2/FXCCA2)

- Connects an Optos clerestory wall with an Altos wall at 90°
- Available in a Clear Anodized or Painted finish, Fascia Laminates or Flintwood
- Available in 1" height increments of 46"-120"

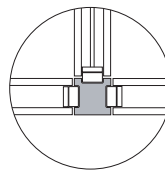

Optos Clerestory Three-Way Connection with Altos (FZCCA3/FXCCA3)

- Connects an Optos clerestory wall with two Altos walls
- Available in a Clear Anodized or Painted finish, Fascia Laminates or Flintwood
- Available in 1" height increments of 94"-120"

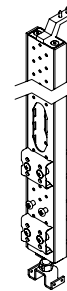

Optos Clerestory Vertical Post (FZCFV/FXCFV)

- Is the full height vertical support for walls with Optos clerestory modules.
- Includes enough Fascia connectors and bolts to support horizontal mounting at up to three levels (working wall)
- Is used to connect a clerestory module to another clerestory module or to an Optos wall or to a corner connection.
- Available in 1" height increments of 94"-120"

clerestory basics (continued)

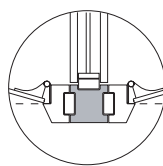
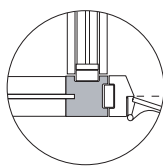
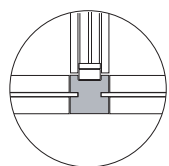
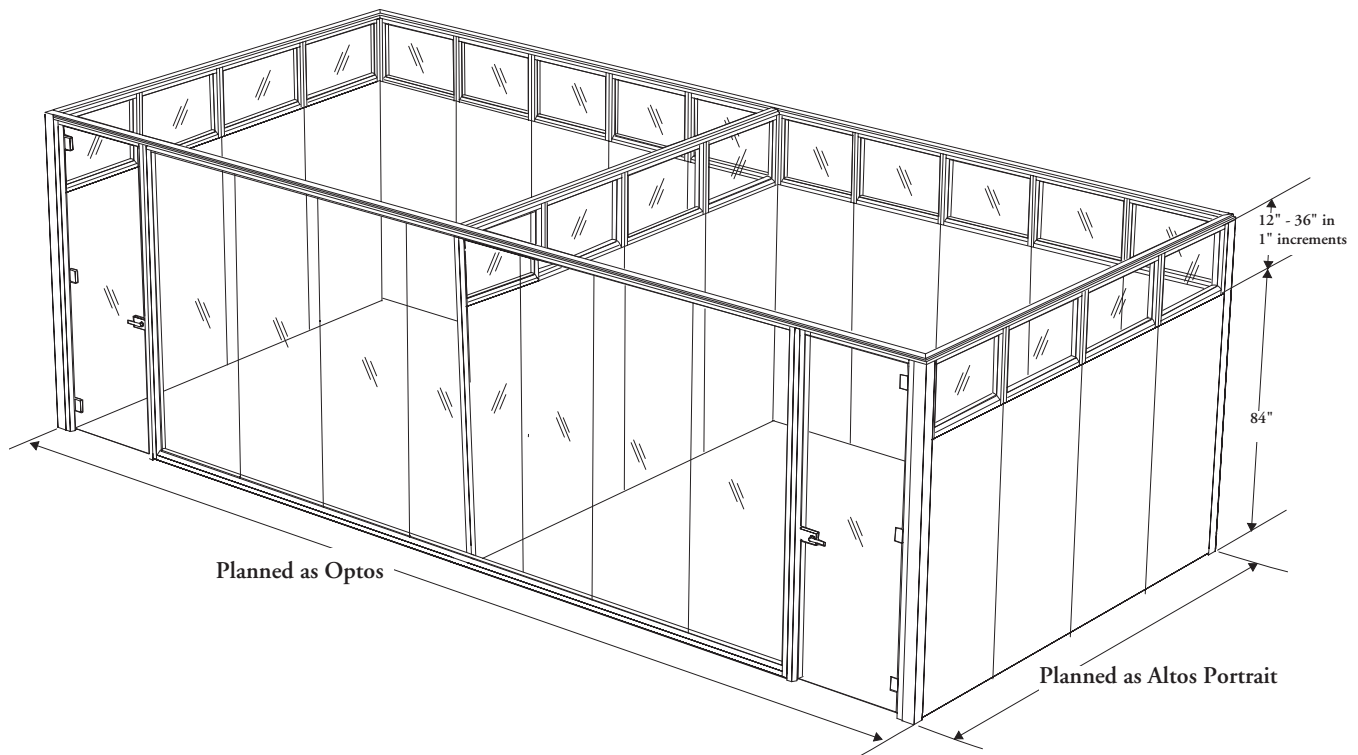

Optos Clerestory Three-Way Connection with Optos (FZCCX3/FXCCX3)

- Connects an Optos clerestory wall with two Optos walls or two Optos door frames
- Available in a Clear Anodized or Painted finish
- Available in 1" height increments of 94"-120"

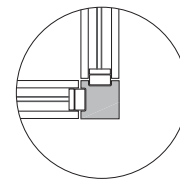

Optos Clerestory Two-Way 90° Corner Connection (FZCCY2/FXCCY2)

- Connects two Optos clerestory walls at 90°
- Available in a Clear Anodized or Painted finish, Fascia Laminates or Flintwood
- Available in 1" height increments of 94"-120"

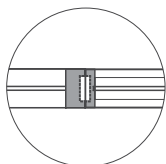

Optos Clerestory In-Line Connection with Optos (FZCCX1/FXCCX1)

- Connects a wall with Optos clerestory in line with a full-height Optos wall
- Available in a Clear Anodized or Painted finish
- Available in 1" height increments of 94"-120"

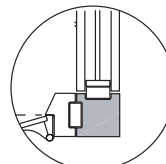
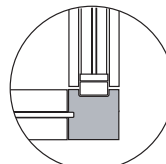

Optos Clerestory Two-Way 90° Corner Connection with Optos (FZCCX2/FXCCX2)

- Connects an Optos clerestory wall to a full-height Optos wall or Optos door frame at 90°
- Available in a Clear Anodized or Painted finish
- Available in 1" height increments of 94"-120"

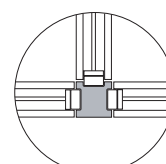

Optos Clerestory Three-Way Connection (FZCCY3/FXCCY3)

- Connects three Optos clerestory walls
- Available in a Clear Anodized or Painted finish, Fascia Laminates or Flintwood
- Available in 1" height increments of 94"-120"

clerestory basics (continued)

Optos clerestory walls must be used in conjunction with an Optos Wall and cannot be used to create enclosures on their own.

- Optos clerestory is used above an 84" high Altos Portrait module
- Clerestory modules help to maintain a uniform and continuous look between Optos and Altos wall systems
- Planning with Optos clerestory on demising walls and back walls of private offices maximize light transmission while maintaining functionality and privacy
- Clerestory modules follow Altos planning rules
- Solid Altos Portrait Fascias below the Optos clerestory can provide added functionality such as whiteboards, tackboards and the ability to hang furniture

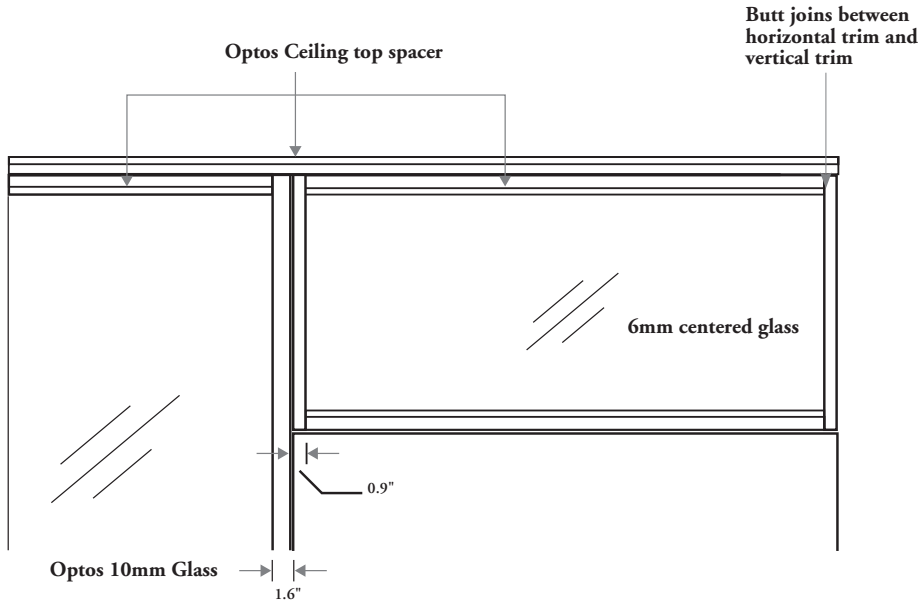

Altos Fascia Elevation types below Optos Clerestory are available as follows (elevations are shown 84" height):

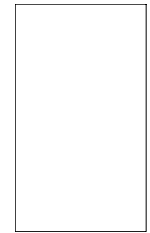

Segmented Monolithic

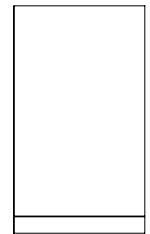

Segmented

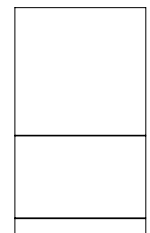

Working Wall

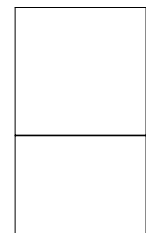

Working Wall Monolithic

Same horizontal trim profile

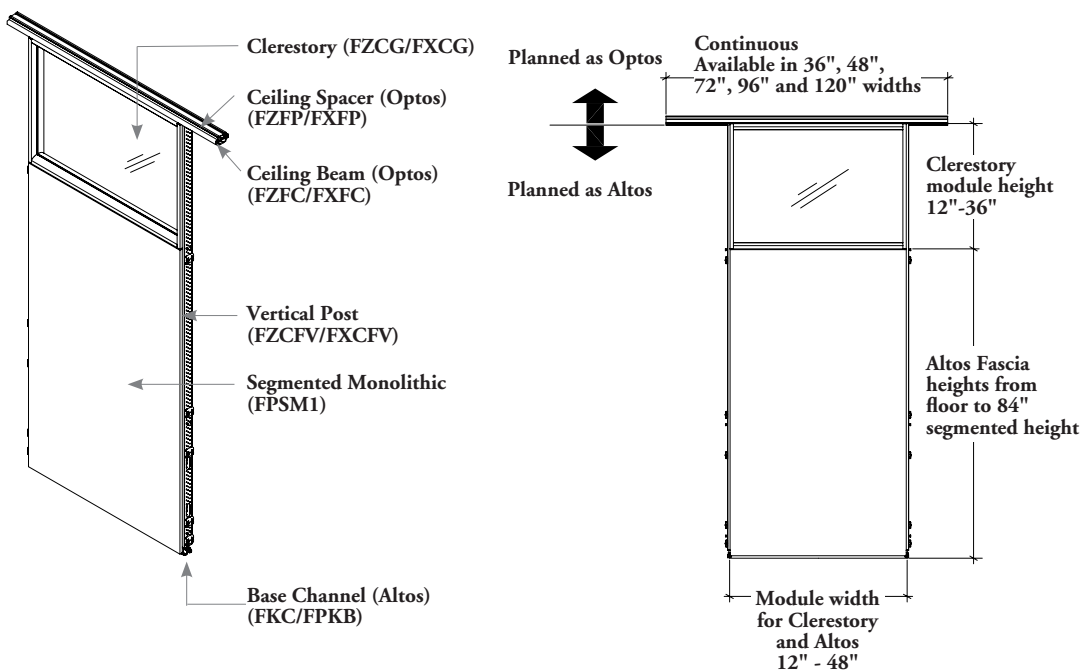

clerestory planning rules

The following details should be taken into consideration when planning with Optos clerestory.

When an Optos Clerestory Wall connects to an existing building, use the Altos Wall Start (FKW/FPKW).

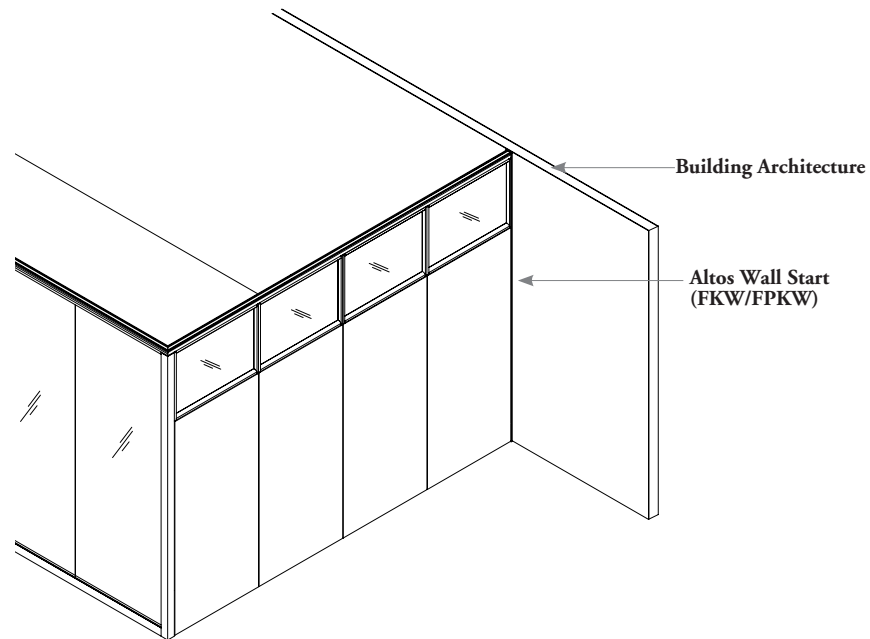

- Optos clerestory **cannot** be used above Optos or Altos doors
- It can only be used above Altos Portrait Fascias

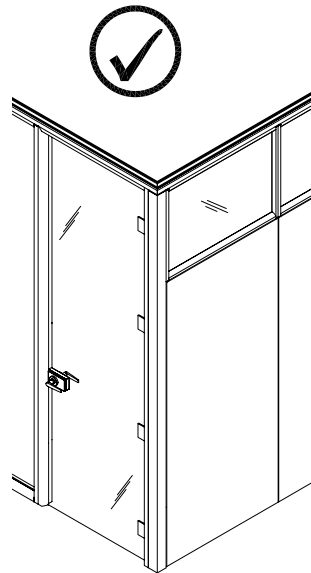
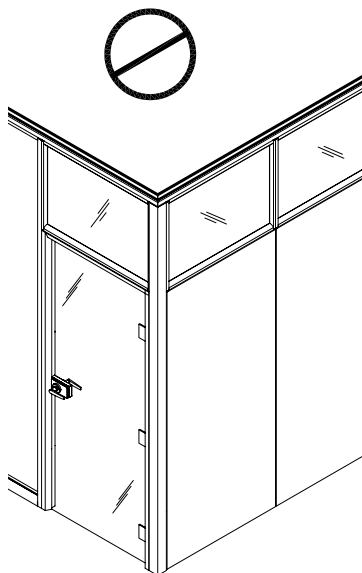

clerestory planning rules (continued)

The following details should be taken into consideration when planning with Optos clerestory.

Optos clerestory **cannot** be used in-line with Optos doors

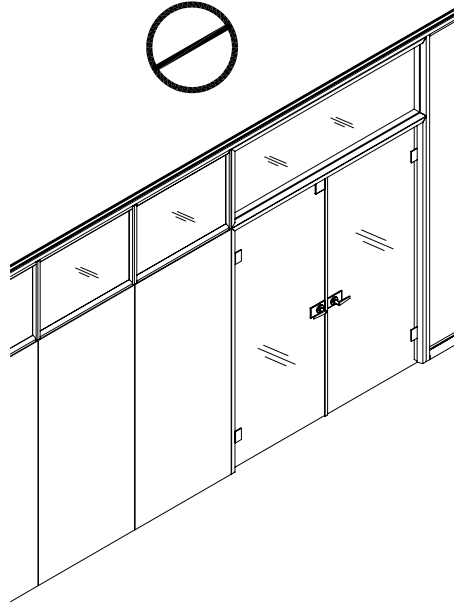

- Optos clerestory **cannot** connect inline with Altos. Inline connections can only be made with Optos or another Optos Clerestory module
- Optos clerestory must be used in conjunction with an Optos wall

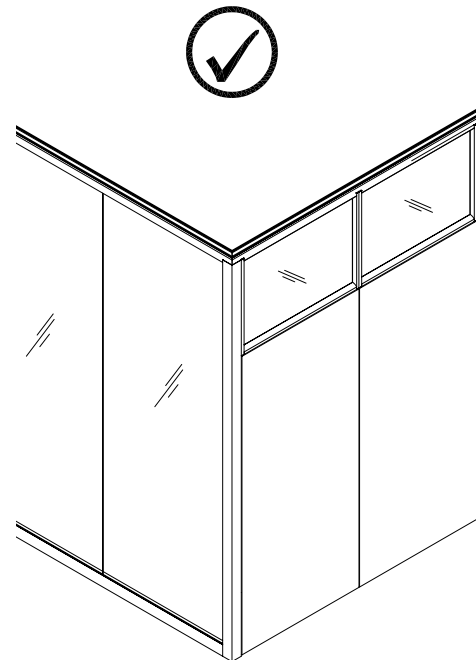
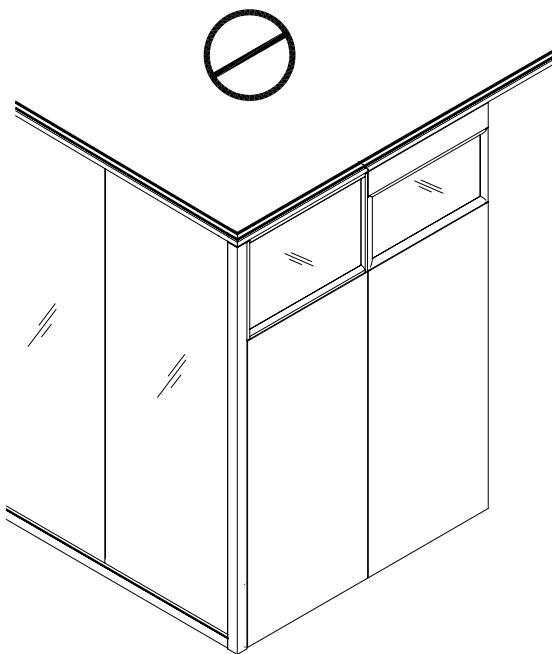

portrait –
lighting, electrics &
communications

portrait – lighting, electrics & communications

LIGHTING OVERVIEW	147
ELECTRICS & COMMUNICATIONS OVERVIEW	148
ACCESS TO ELECTRICS & COMMUNICATIONS	149
HARDWIRE ELECTRICS & COMMUNICATIONS BASICS	152
PLANNING WITH HARDWIRE ELECTRICAL & COMMUNICATIONS	153
MODULAR ELECTRICS BASICS	154
PLANNING WITH MODULAR ELECTRICS	156
MODULAR ELECTRICS COMPATIBILITY CHART	160
POWER PLUS COMMUNICATIONS MODULE ELECTRICS BASICS	162
PLANNING WITH POWER PLUS COMMUNICATIONS MODULES	163
POWER PLUS COMMUNICATIONS MODULE COMPATIBILITY CHART	164
DETERMINING ELECTRICS & COMMUNICATIONS REQUIREMENTS	166
SPECIFYING ALTOS ELECTRICS & COMMUNICATIONS	169

A light switch is available in Altos that allows user control of ambient lighting.

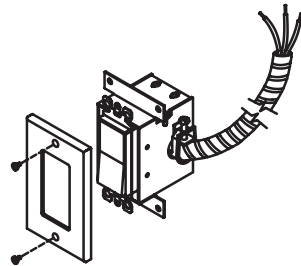

Light Switch (ELS)

- Allows for user control of individual office ambient light
- Can be installed on solid Fascias
- Is recommended to locate the cut out 42" above finished floor to the center-line of the light switch



Solid: Full
(FPVSF)



Solid: Segmented
(FPVSS)



Solid: Working Wall
(FPVSW)

electrics & communications overview

There are four methods of supplying power and communications in Altos Portrait, each method functions differently. The following chart will help you select the appropriate solution.

	Field-supplied Electrics	Hardwire Electrics	Modular Electrics	Power Plus Communications Electrics
application	<ul style="list-style-type: none"> • Uses industry standard receptacles commonly used in drywall applications • Contractor provides all electrical components – only the Fascias are specified with cut outs • Client customized 	<ul style="list-style-type: none"> • Used in single office applications • Individual feed to each receptacle 	<ul style="list-style-type: none"> • Used with systems furniture applications • Allows for spine planning and routing power between receptacles 	<ul style="list-style-type: none"> • Used in single office applications • Individual feed to each box with disconnect in ceiling • Each box can hold 1 data plus 1-3 Duplex
benefits	<ul style="list-style-type: none"> • Contractor provides all electrical components • Fascia cut outs accept industry standard duplex or decora style receptacles 	<ul style="list-style-type: none"> • Industry standard receptacle module pre-wired with 20' – 0" cable • Includes standard electrical box, decora receptacle and faceplate • Standard and isolated circuits • 120 volt; 15 and 20 amp options • Communications module accepts modular furniture or decora strap faceplates • Voice/data jacks and cabling not included 	<ul style="list-style-type: none"> • Allows power to be routed between receptacles • Single and double sided power boxes correspond to wire system • Communications box accepts modular furniture faceplates • Voice/data jacks and faceplates not included 	<ul style="list-style-type: none"> • 120 volt; 15 amp and 20 amp options • Communication opening accepts modular furniture faceplates • 1 faceplate is used for the entire box
features	<ul style="list-style-type: none"> • Compatible with standard electrical wiring systems 	<ul style="list-style-type: none"> • Compatible with standard electrical wiring systems • Each receptacle fed individually • Does not route power between receptacles 	<ul style="list-style-type: none"> • Available in many wire systems • Reduces number of feeds required • Cost effective • Easy to reconfigure • Compatible with systems furniture • Requires fewer connections to building power 	<ul style="list-style-type: none"> • Available in many wire systems • Compatible with standard electrical wiring systems • Does not route power between receptacles • Single box for power and data • Easy to disconnect for relocation
wire systems	<ul style="list-style-type: none"> • Standard Circuit • Isolated Circuit 	<ul style="list-style-type: none"> • Standard Circuit • Isolated Circuit 	<ul style="list-style-type: none"> • 4B • 8T • 5D • 8N • 7G • 8K 	<ul style="list-style-type: none"> • 4B • 8T • 5D • 8K • 6G • 7G
electrical components available		<ul style="list-style-type: none"> • Receptacle Module (ERM) • Communications Module (ECM) • Light Switch (ELS) • Fascia Cover Cap (EFCC) 	<ul style="list-style-type: none"> • Ceiling/Underfloor Feed (ECF) • Single Power Box (ERAS) • Double Power Box (ERAD) • Two-Sided Power Box (ERAB) • Communications Box (ERC) • Power Harness (EB) • Transition Harness (EBT) • Modular Power Distribution Box (EFA) • Mounting Rail (EMR) • Fascia Cover Cap (EFCC) 	<ul style="list-style-type: none"> • Power Plus Communications Module – Single (ERGMS) • Power Plus Communications Module – Double (ERGMD) • Power Plus Communications Module – Triple (ERGMT) • Power Plus Communications Module – Quad (ERGMQ) • Power Plus Communications Module Starter Cable (ERSC)

access to electrics & communications

The following should be considered for access to power communications and lighting.

light switches

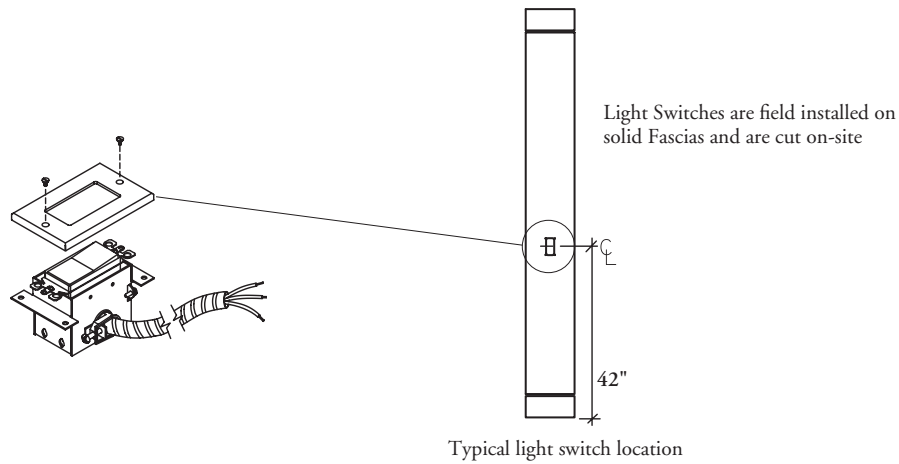

fascia cut out locations

Fascia cut outs are required for accessing power and communications. Cut out locations vary depending on the application type.

Base Height

Applicable to hardwire and modular

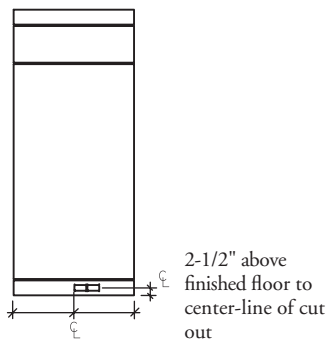

18" Height – Vertical cut outs

Applicable to hardwire and power plus communications module

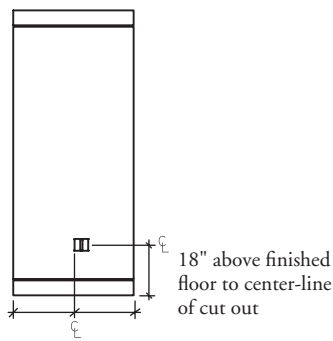

18" Height – Horizontal cut outs

Applicable to hardwire and modular

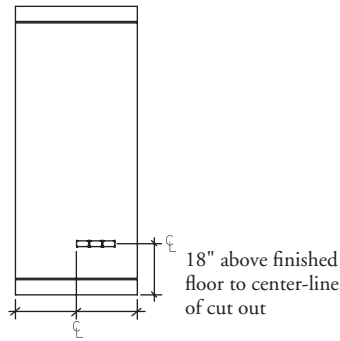

Worksurface Height

Applicable to hardwire

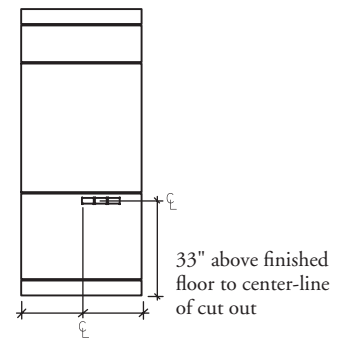











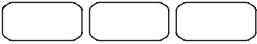

- All cut outs are located right of center-line on the front of the Fascia so electrics and communications can be specified on both inner and outer elevations of the same wall module
- At worksurface and base height, cut outs are always oriented horizontally
- For 18" height, the cut outs are oriented vertically for hardwire electrics and horizontally for modular electrics

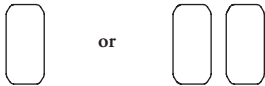
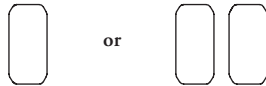



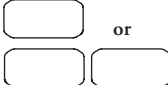
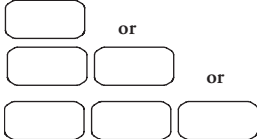

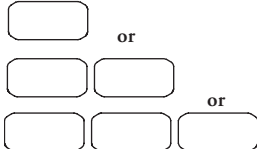

fascia power/communication cut outs

The number of cut outs for hardwire, modular and power plus communications module electrics depends on Fascia width. The chart below outlines the number of openings available by size in Altos Portrait.

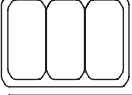
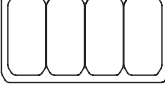
Fascia Cover Caps (EFCC) can be ordered to cover unused cut outs by size.

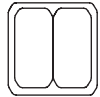
Cut Out Height	Fascia Widths		
	12" – 20"	21" – 29"	30" – 48"
Worksurface – Hardwire  1 cut out (FPF12, FPS12, FPW12) Application - either power or communication	 2 cut outs (FPF12, FPS12, FPW12) Application - any combination of power or communication	 3 cut outs (FPF12, FPS12, FPW12) Application - Any combination of power or communication	
Worksurface – Modular Electrics  1 cut out (FPF12, FPS12, FPW12) Application - communication only	 2 cut outs (FPF12, FPS12, FPW12) Application - 12" to 24" out power only; 25" to 39" up to two power	 3 cut outs (FPF12, FPS12, FPW12) Application - 25" to 39" two power only; 40" to 48" up to three power	
18" Height – Hardwire cut out oriented vertically  1 cut out (FPF14, FPS14, FPW14) Application - either power or communication	 1 cut out (FPF14, FPS14, FPW14) or 2 cut outs (FPF13, FPS13, FPW13) Application - any combination of power or communication	 1 cut out (FPF14, FPS14, FPW14) or 2 cut outs (FPF13, FPS13, FPW13) Application - any combination of power or communication	
18" Height – Modular Electrics cut out oriented horizontally  1 cut out (FPF15, FPS15, FPW15) Application - communication only	 2 cut outs (FPF15, FPS15, FPW15) Application - 12" to 24" only power only; 25" to 39" up to two power	 3 cut outs (FPF15, FPS15, FPW15) Application - 25" to 39" two power only; 40" to 48" up to three power	
Base Height – Hardwire (applicable to 6" base only)  1 cut out (FPB2) Application either power or communication	 1 cut out (FPB2) or 2 cut outs (FPB3) Application - 12" to 24" one power only; 25" to 39" up to two power	 1 cut out (FPB2) or 2 cut outs (FPB3) or 3 cut outs (FPB4) Application - combination of power or communication	
Base Height – Modular Electrics (applicable to 6" base only)  1 cut out (FPB2) Application - communication only	 1 cut out (FPB2) or 2 cut outs (FPB3) Application - 12" to 24" one power only; 25" to 39" up to two power	 1 cut out (FPB2) or 2 cut outs (FPB3) or 3 cut outs (FPB4) Application - 25" to 39" two power only; 40" to 48" up to three power	

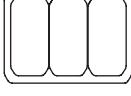
fascia power/communication cut outs (continued)

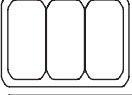
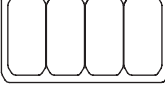
Cut Out Height	Fascia Widths			
	13" – 16"	17" – 20"	21" – 24"	25" - 48"
18" Height Power Plus Communications Module				 or  or  or 
power data module	 Single (S) – ERGS	 or  Single (S) – ERGS Double (D) – ERGD	 or  or  Single (S) – ERGS Double (D) – ERGD Triple (T) – ERGT	 or  or  or  Single (S) – ERGS Double (D) – ERGD Triple (T) – ERGT Quad (Q) – ERGQ

hardwire electrics & communications basics

Hardwire components consist of receptacle modules, communications modules and power distribution boxes.

- Connection to building supply must be done by a qualified electrician
- Fascia cut outs may not accept client-supplied standard electric/data boxes, receptacles and faceplates, the factory cut outs match factory electrics
- One size cut out fits both receptacle and communications modules. Any combination of Receptacles or Communications Modules are possible

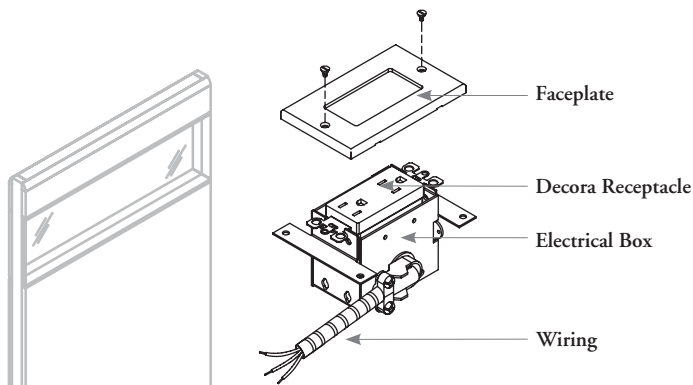

Receptacle Module (ERM)

- Provides access to electrical power and can be installed at all Fascia cut outs located at base height, 18" height, and worksurface height
- Available in Standard or Isolated Ground
- Pre-wired with 20'-0" cable
- Altos receptacles are standard 120-volt with a choice of 15 or 20 amps
- Comes ready for installation and includes a standard electrical/data box, decora receptacle and faceplate

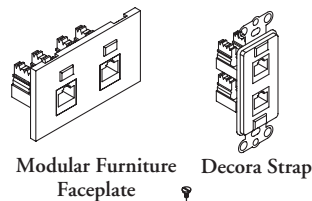

Communications Module (ECM)

- Voice and data are brought to the workspace via the Communications Module and can be used in all Fascia cut outs located at base height, 18" high and worksurface height
- Accepts modular furniture or decora strap faceplates
- Jacks/faceplates and cabling not included
- Can be specified to accept the pictured two faceplates
- Can be specified to accept twisted pair, fiber optic or coaxil cable (supplied by others)

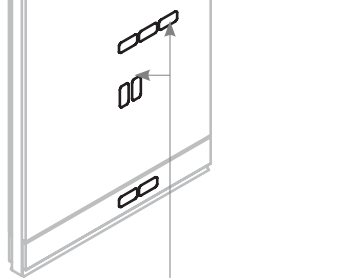

Electrical and communication cut outs installed in these locations

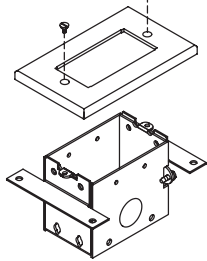

- One size cut out fits both receptacle and Communications Modules
- Any combination of Receptacles or Communications Module are possible

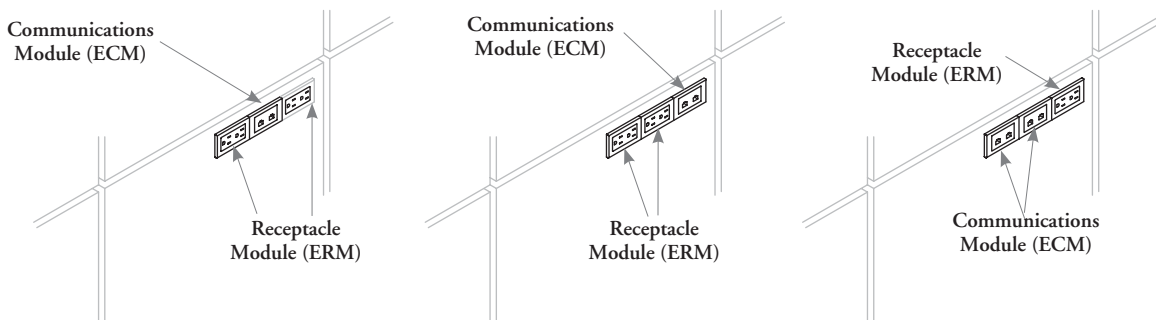

planning with hardwire electrical & communications

The following should be considered when planning with hardwire electrics and communications.

Electrical and communication cables are fed from the ceiling or from access floors through cut outs in the Ceiling or Base Channels to Receptacle and Communications Modules.

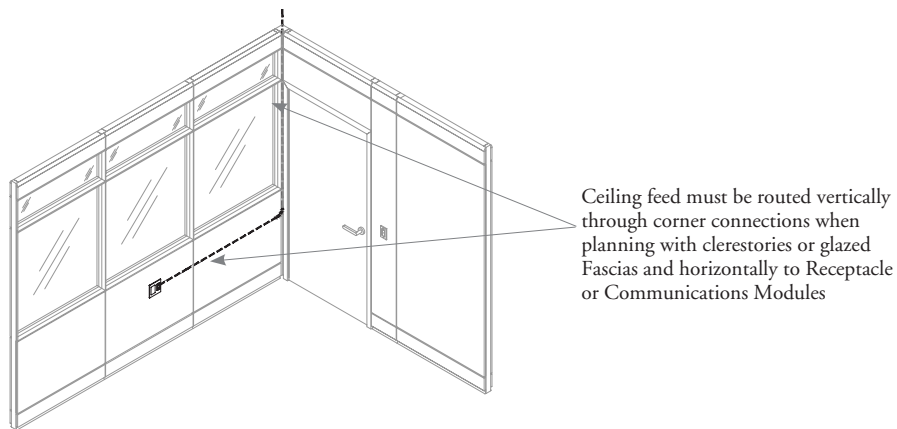
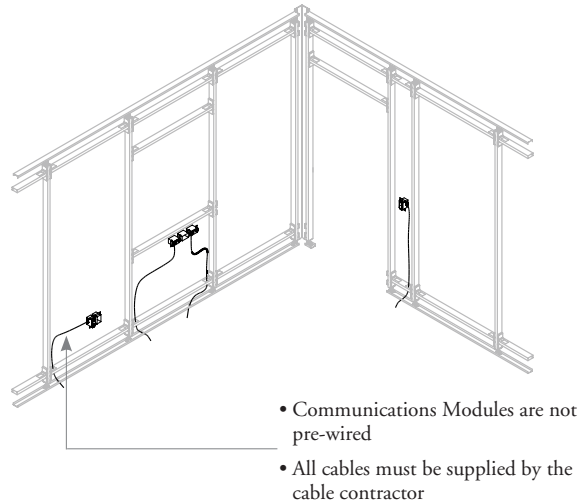
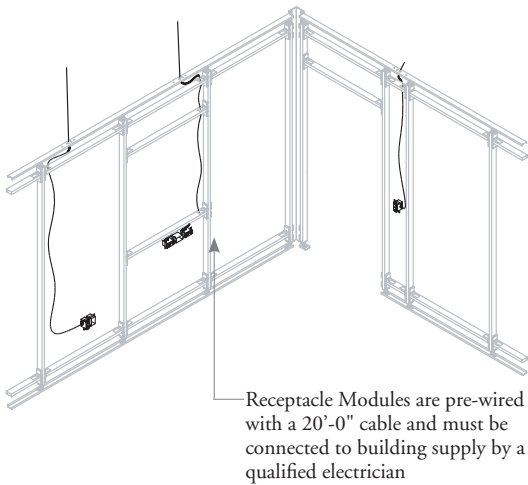

Standard Circuit

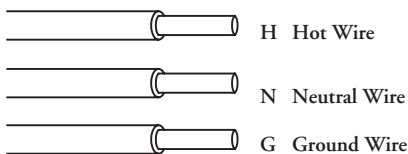

Isolated Ground Circuit

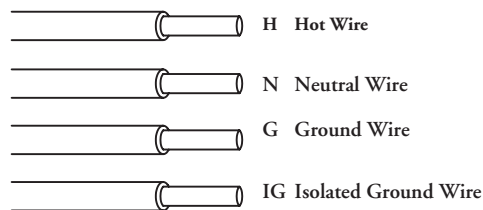

Altos Receptacle Modules (ERM) and Light Switches (ELS) are compatible with standard electrical wiring systems used in drywall building applications. These consist of three wires (one circuit) for standard circuits and four wires for isolated ground circuits. This simplified approach to power eliminates the need for coordinating various circuit configurations. Receptacles can be specified as standard or isolated ground

modular electrics basics

Modular electrics consists of components that allow systems furniture to be powered directly from Altos walls.

- All components must be specified from same wire system – systems available – 4B, 5D, 7G, 8T, 8N and 8K
- Power from a single building supply may be routed to multiple offices
- Back-to-back installation of electrics and communications is possible by off-set mounting on the Fascia

Ceiling/Underfloor Feed (ECF)

- Hardwired to the building power supply and brings power to other modular electrics products
- Available in 120", 240" and 360" lengths
- Must be routed through solid Fascias or corner connections (any elevation) – **cannot** be routed through Fascias with glass

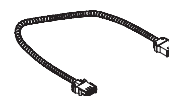

Power Harness (EB)

- Routes power between power boxes and distribution boxes
- Available in 72", 96", 120" and 144" lengths
- Links power harnesses or Transitional Harnesses (EBT) to one another
- Maximum number of Power Boxes chained by one circuit is limited by electrical loads
- Includes a jack end and a plug end for connecting – the jack end securely links to the plug end of connecting products and the plug end securely links to the jack end of connecting product

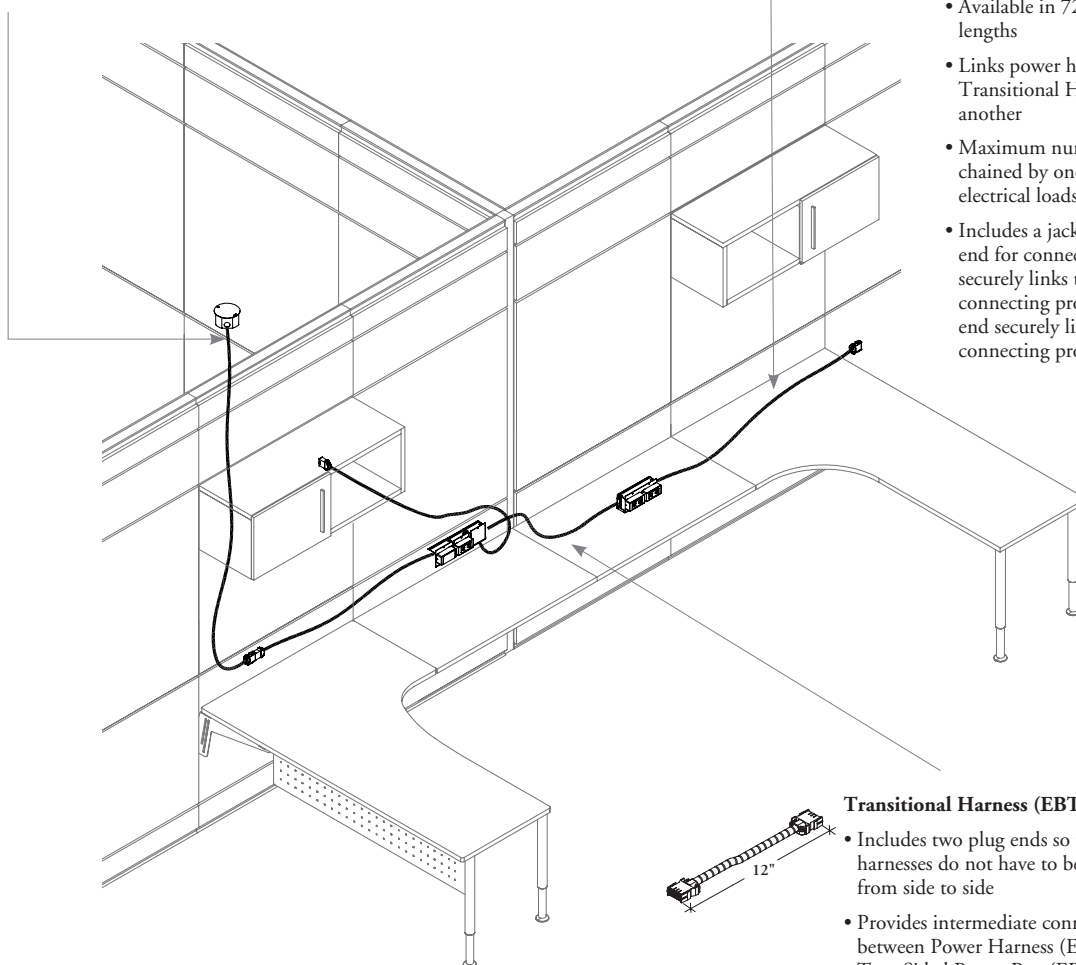

Transitional Harness (EBT)

- Includes two plug ends so that harnesses do not have to be looped from side to side
- Provides intermediate connection between Power Harness (EB) and Two-Sided Power Box (ERAB)

modular electrics basics (continued)

Modular electrics consists of components that allow systems furniture to be powered directly from Altos walls.

- All components must be specified from same wire system – systems available – 4B, 5D, 7G, 8T, 8N and 8K
- Power from a single building supply may be routed to multiple offices
- Back-to-back installation of electrics and communications is possible by off-set mounting on the Fascia

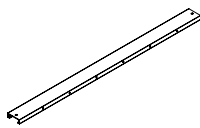

Mounting Rail (EMR)

- Must be specified separately to attach the Power Box and Communications Box to the Horizontal Rail
- The specified nominal width of the Mounting Rail must equal the width of the mounting Horizontal Rail
- In addition, a Horizontal Rail-Single (FPKHG) must be specified when the Power Box and Communications Box are located at the 18" high cut out on all Fascias or the 36" high cut out on Full and Segmented Fascias

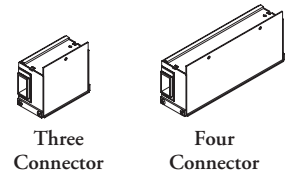

Modular Power Distribution Box (EFA)

- Routes power in different directions – three-connector options routes in two directions and the four-connector options routes in three directions
- Connects directly to power boxes
- Non-directional
- A Mounting Rail (EMR) must be specified when it is positioned within a Fascia that does not have a power box
- A horizontal rail – single may be specified when located at the 18" high cut out on all Fascias or the 36" high cut out on full and segmented Fascia
- Also used adjacent to corner connections to route power to different directions

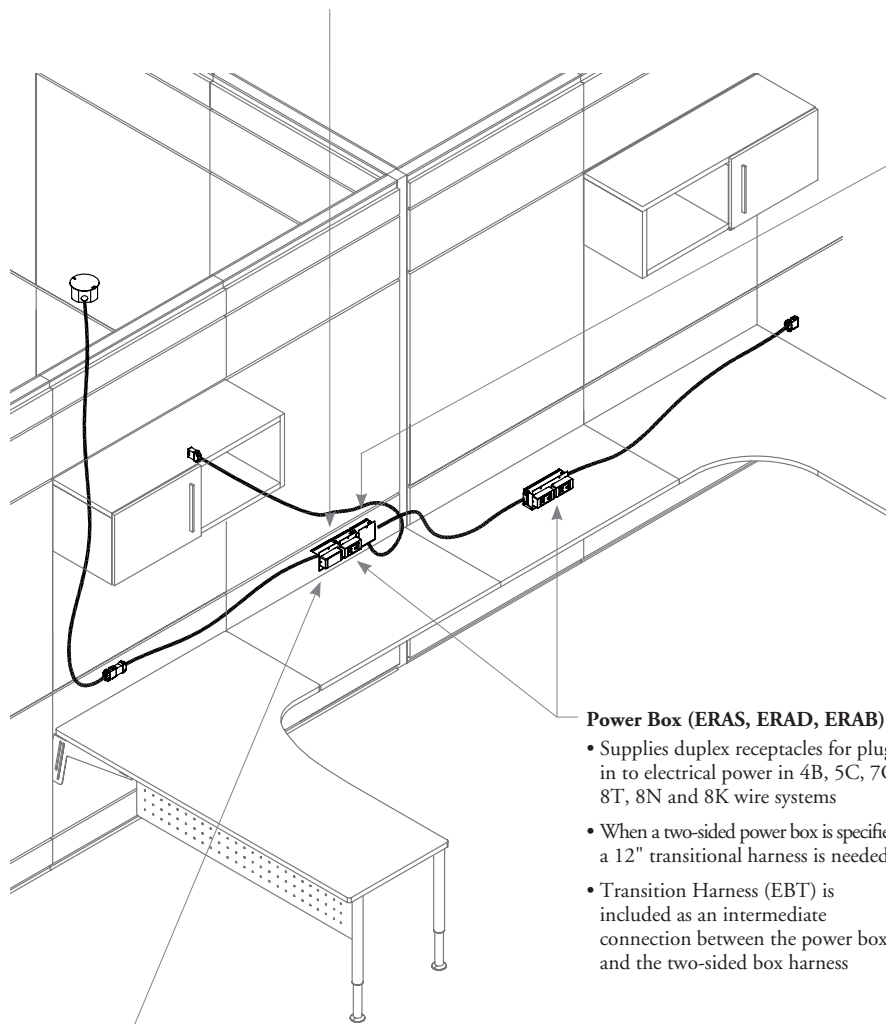

Power Box (ERAS, ERAD, ERAB)

- Supplies duplex receptacles for plug in to electrical power in 4B, 5C, 7G, 8T, 8N and 8K wire systems
- When a two-sided power box is specified a 12" transitional harness is needed
- Transition Harness (EBT) is included as an intermediate connection between the power box and the two-sided box harness

Communications Box (ERC)

- Delivers voice and data to the workplace and can be used in conjunction with the power box
- Accepts modular furniture faceplates
- Jacks and faceplates and conduit are not included
- Not pre-wired

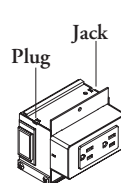
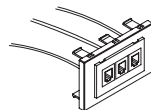

Single Power Box one duplex receptacle (ERAS)

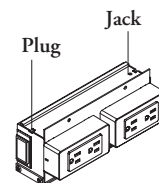

Double Power Box two duplex receptacles (ERAD)

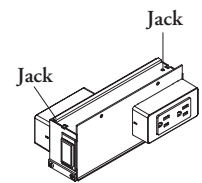

Two-Sided Power Box one duplex receptacle on each side (ERAB)

planning with modular electrics

The following should be considered when planning with modular electrics.

determining proper harness length

same height

To determine the correct power harness length when routing at the same height (e.g. worksurface to worksurface height), see the following chart.

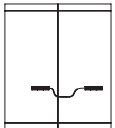
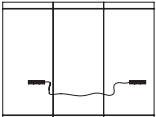
Fascia Condition	12" – 29" wide Fascia	30" – 48" wide Fascia
Powered Fascia to powered Fascia 	48" long Power Harness	48" long Power Harness
Powered Fascia to unpowered Fascia 	48" long Power Harness	72" long Power Harness

change of height

To determine the correct power harness length when routing different heights (e.g., worksurface to base height), see the following chart:

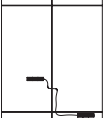
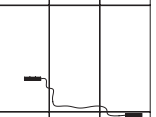
Fascia Condition	12" – 29" wide Fascia	30" – 48" wide Fascia
Powered Fascia to powered Fascia 	48" long Power Harness	72" long Power Harness
Powered Fascia to unpowered Fascia 	72" long Power Harness	96" long Power Harness

passing through more than one wall module

The power harness may also be specified in longer lengths to pass through more than one Fascia provided that length requirements for each wall module is met. For example, a 96" long Power Harness can be specified to pass through two 48" wide wall modules (requirement is 48" for each wall module) where routing is at the same height.

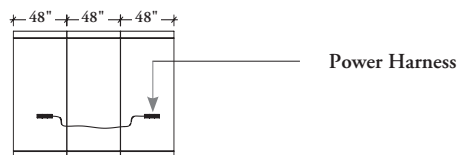

passing through corner connections

To pass through corner connections, the Power Harness should be specified at least 2'-0" longer than usually required.

planning with modular electrics (continued)

connecting modular electrics

Connections are made by linking plugs and jack ends of components:

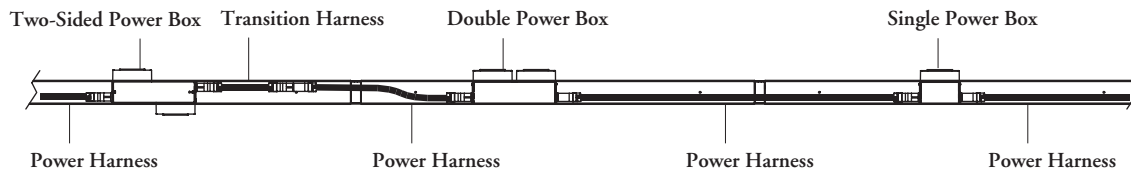
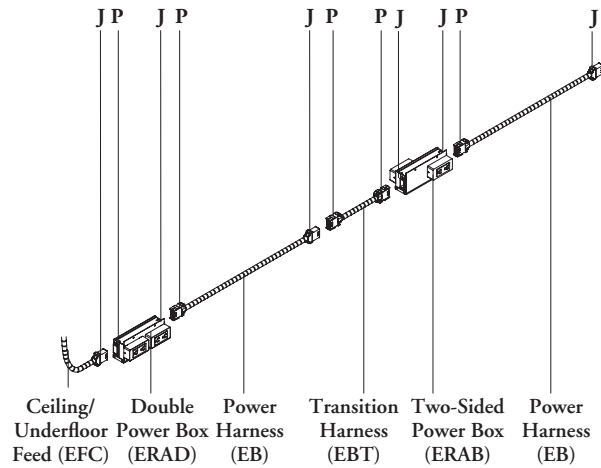

The following chart outlines the jack and plug locations on modular electric components

Ceiling/Underfloor Feed (ECF)

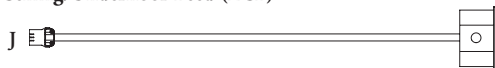

Power Harness (EB)

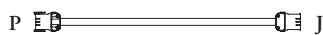

Transition Harness (EBT)



Distributional Box (EFA)

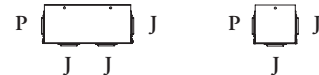

Non-Directional, orientation can be switched

Single Power Box (ERAS)



Double Power Box (ERAD)

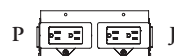

Two-Sided Power Box (ERAB)

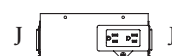

planning with modular electrics (continued)

The following should be considered when planning with modular electrics.

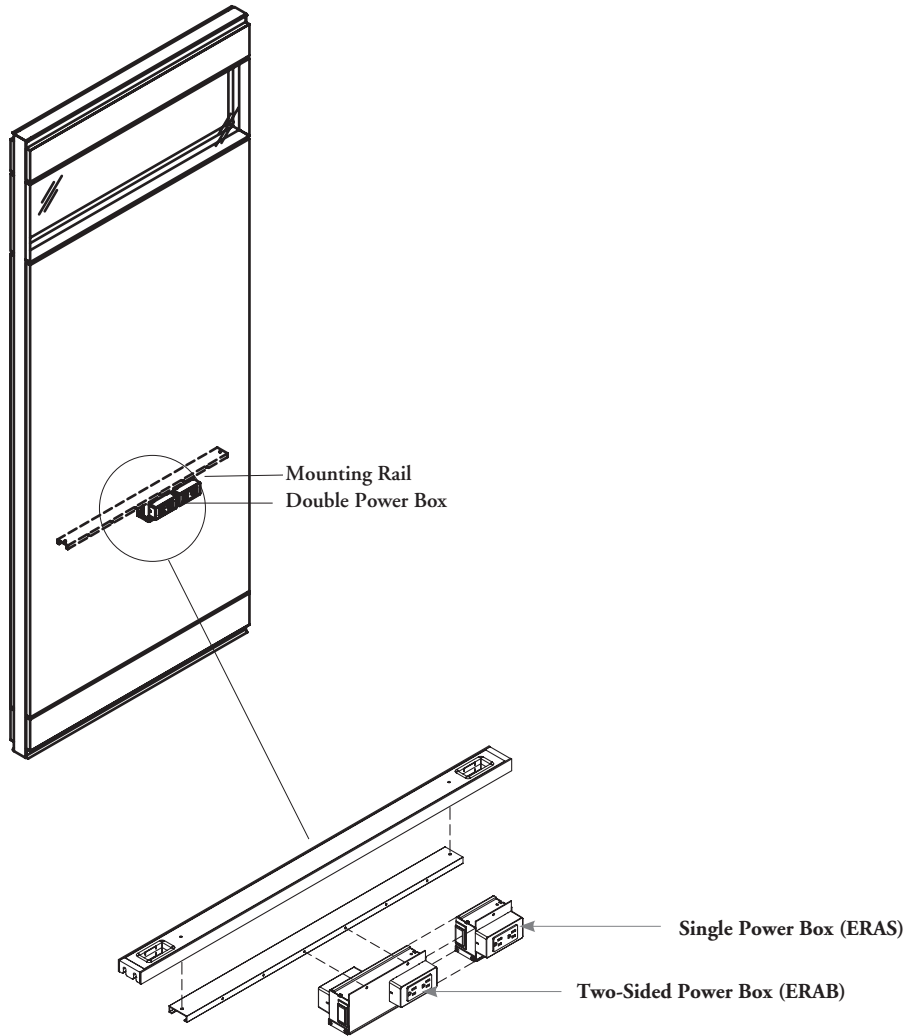

The Communications Box must be located at either end of the power box. It may not be located in between power boxes

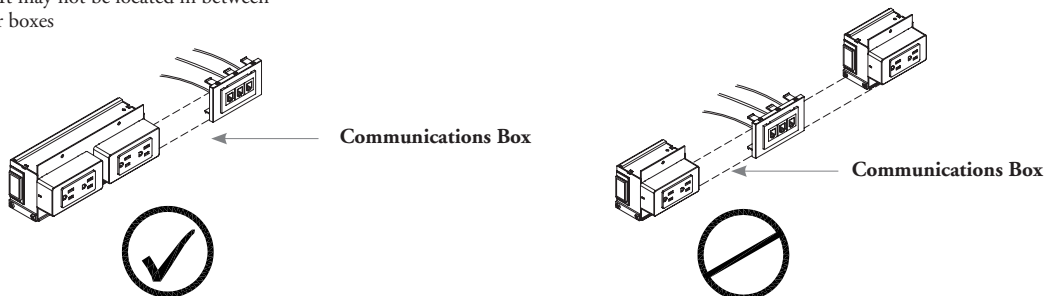

planning with modular electrics (continued)

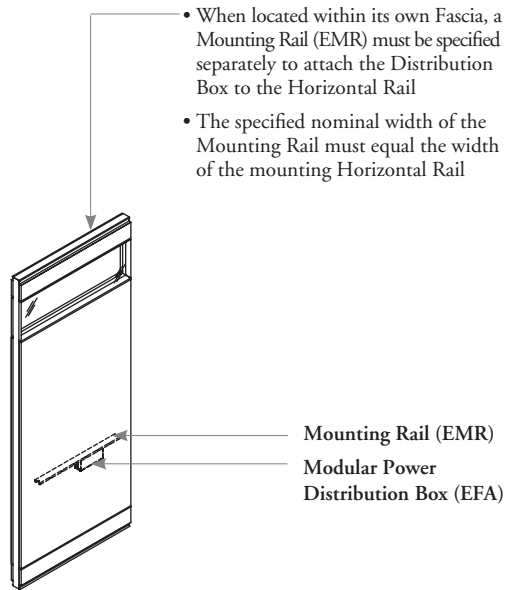

Horizontal Rail-Single (FPKHG) must be specified when the Distribution Box is located at the 18" high cut out location on all Fascias or the 36" high cut out location on full and segmented Fascias

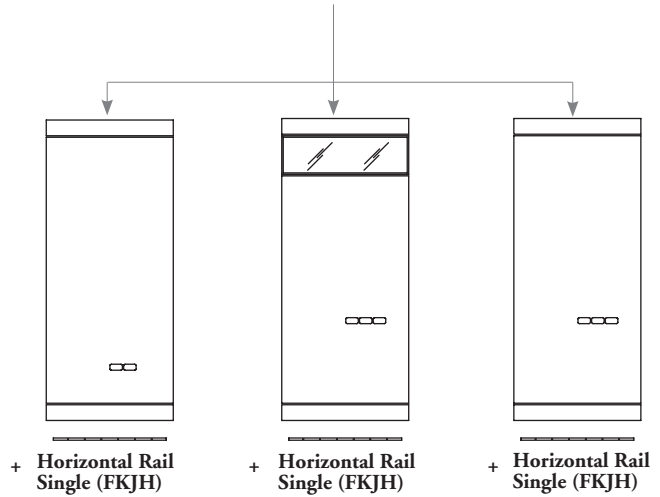

The three-connector Modular Power Distribution Box replaces one cut out

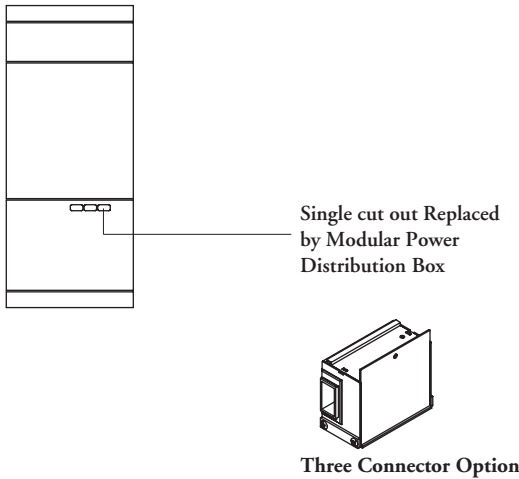

In double-sided applications, the four-connector Modular Power Distribution Box replaces two cut outs

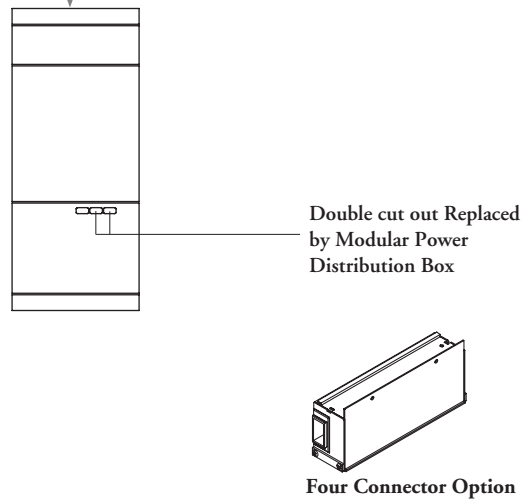

- When the Modular Power Distribution Box is located within a powered Fascia, one Mounting Rail and Horizontal Rail will suspend the Modular Power Distribution Box and Power Box
- The Modular Power Distribution Box connects directly to the electrical outlets of the Power Box without the need for harness cables
- In single-sided applications, the Modular Power Distribution Box can be located so that it does not occupy any cut outs

modular electrics compatibility chart

All modular electrics must be specified according to the wire system in use. The following chart identifies compatibility between Altos modular electrics.

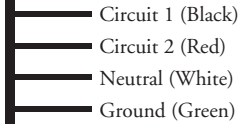
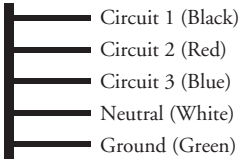
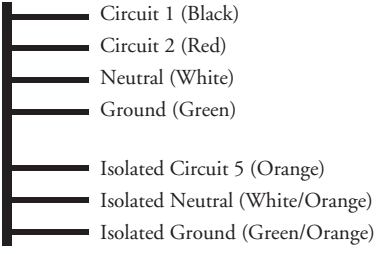
Wire System	Code	No. of Regular Circuits	No. of Isolated Circuits	Compatible Ceiling/ Underfloor Feed	Compatible Power Harness	Compatible Modular Power Distribution Box	Compatible Power Box
4-wire 	4B	2	0	ECF4B	EB4B	EFAT4B EFAF4B	ERAS4B1 ERAS4B2 ERAD4B11 ERAD4B12 ERAD4B22 ERAB4B11 ERAB4B12 ERAB4B22
5-wire 	5D	3	0	ECF5D	EB5D	EFAT5D EFAF5D	ERAS5D1 ERAS5D2 ERAS5D3 ERAD5D11 ERAD5D12 ERAD5D13 ERAD5D22 ERAD5D23 ERAD5D33 ERAB5D11 ERAB5D12 ERAB5D13 ERAB5D22 ERAB5D23 ERAB5D33
7-wire 	7G	2	1	ECF7G	EB7G	EFAT7G EFAF7G	ERAS7G1 ERAS7G2 ERAS7G5 ERAD7G11 ERAD7G12 ERAD7G15 ERAD7G22 ERAD7G25 ERAD7G55 ERAB7G11 ERAB7G12 ERAB7G15 ERAB7G22 ERAB7G25 ERAB7G55

modular electrics compatibility chart (continued)

All modular electrics must be specified according to the wire system in use. The following chart identifies compatibility between Altos modular electrics.

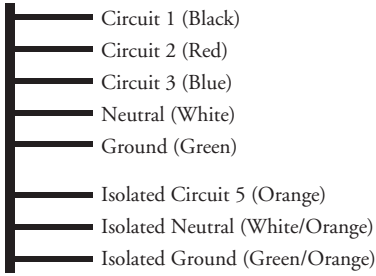
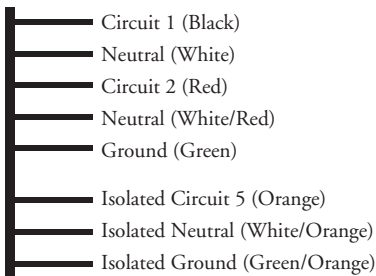
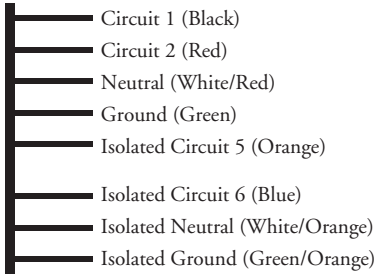
Wire System	Code	No. of Regular Circuits	No. of Isolated Circuits	Compatible Ceiling/ Underfloor Feed	Compatible Power Harness	Compatible Modular Power Distribution Box	Compatible Power Box
8-wire, Isolated Ground 	8T	3	1	ECF8T	EB8T	EFAT8T EFAF8T	ERAS8T1 ERAS8T2 ERAS8T2 ERAS8T5 ERAD8T11 ERAD8T12 ERAD8T13 ERAD8T15 ERAD8T22 ERAD8T25 ERAD8T33 ERAD8T35 ERAD8T55 ERAB8T11 ERAB8T12 ERAB8T13 ERAB8T15 ERAB8T22 ERAB8T23 ERAB8T25 ERAB8T33 ERAB8T35 ERAB8T55
8-wire, Separate Neutral 	8N	2	1	ECF8N	EB8N	EFAT8N EFAF8N	ERAS8N1 ERAS8N2 ERAS8N5 ERAD8N11 ERAD8N12 ERAD8N15 ERAD8N22 ERAD8N25 ERAD8N55 ERAB8N11 ERAB8N12 ERAB8N15 ERAB8N22 ERAB8N25 ERAB8N55
8-wire, Dual Isolated 	8K	2	2	ECF8K	EB8K	EFAT8K EFAF8K	ERAS8K1 ERAS8K2 ERAS8K5 ERAS8K6 ERAD8K11 ERAD8K12 ERAD8K15 ERAD8K16 ERAD8K22 ERAD8K25 ERAD8K26 ERAD8K55 ERAD8K56 ERAD8K66 ERAB8K11 ERAB8K12 ERAB8K15 ERAB8K16 ERAB8K22 ERAB8K25 ERAB8K26 ERAB8K55 ERAB8K56 ERAB8K66

power plus communications module electrics basics

Power Plus communication modules allow office spaces to be powered directly from Altos walls.

- All components must be specified from same wire system – systems available – 4B, 5D, 6G, 7G, 8T and 8K
- Power from a single building supply may be routed to multiple offices
- Back-to-back installation of electrics and communications is possible because electrical box mounting is offset on the fascia.



Power Plus Communications Module Starter Cable (ERSC)

- Is used at every location that Power Plus Communications Modules are used to connect the electrics to the ceiling power
- Available 12" long and in 4B, 5D, 6G, 7G, 8T and 8K wiring systems

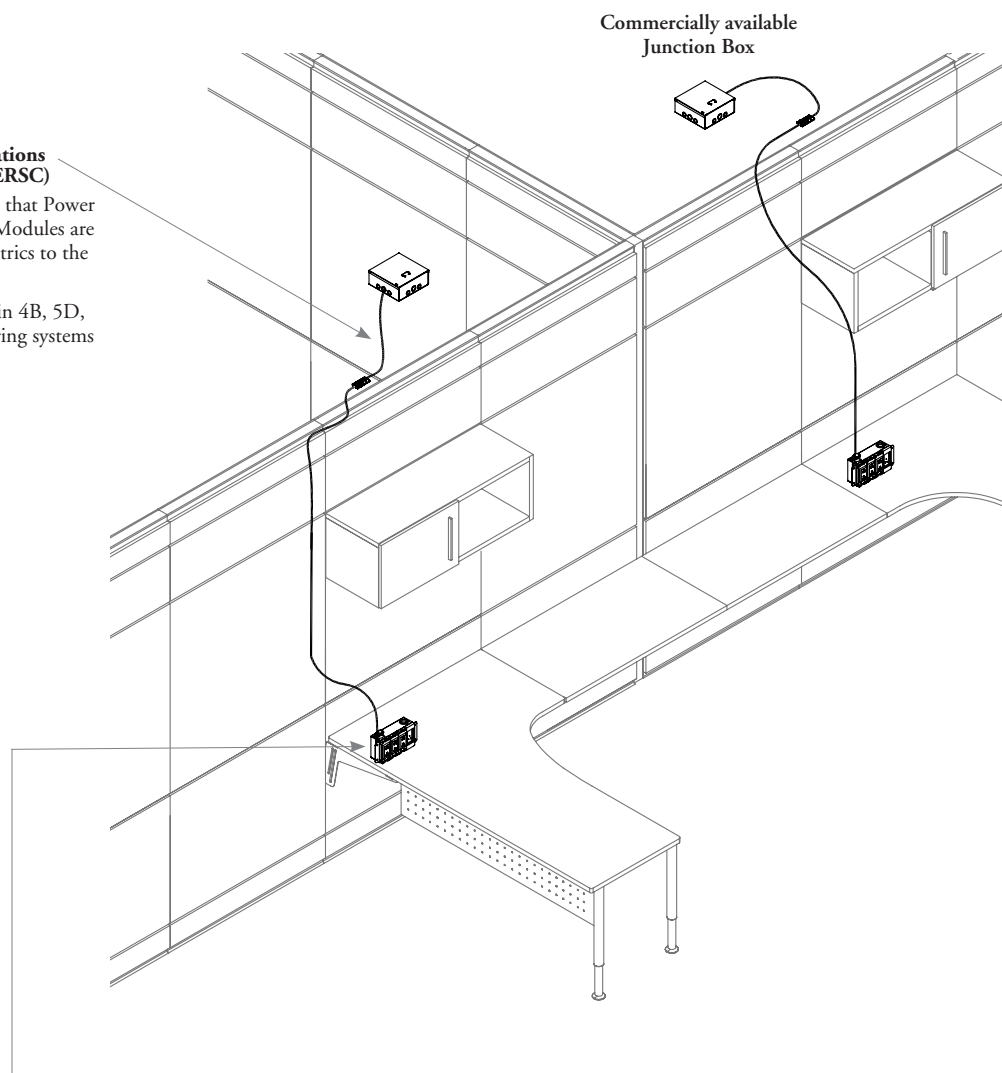

Power Plus Communications Module (ERGMS, ERGMD, ERGMT, ERGMQ)

- Provides data and 1-3 duplexes on one faceplate for single office applications
- Each feed routes directly to the Power Plus Communications Module
- Cable lengths are available 20' and 30' long
- No option for only Data
- Available 120 volt and 15 amp or 20 amp
- Available in Single (ERGMS), Double (ERGMD), Triple (ERGMT) and Quad (ERGMQ) options
- Faceplates are available in E1 Black or E2 White
- Solid Portrait Fascias are available with cut outs to match each Power Plus Communications Module types. See the Fascias section for more details

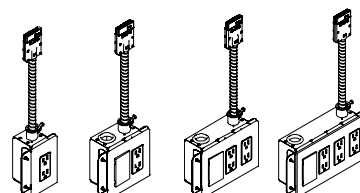

planning with power plus communications modules

The following should be considered when planning with power plus communications modules.

underfloor and ceiling feeds

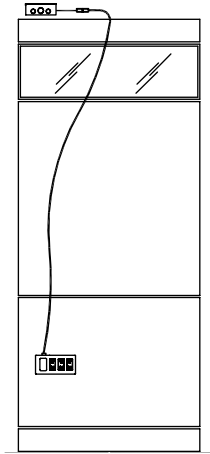

The Power Plus Communications Module Starter Cable (ERSC) **cannot** be routed through Fascia packages that include glazed Fascias.

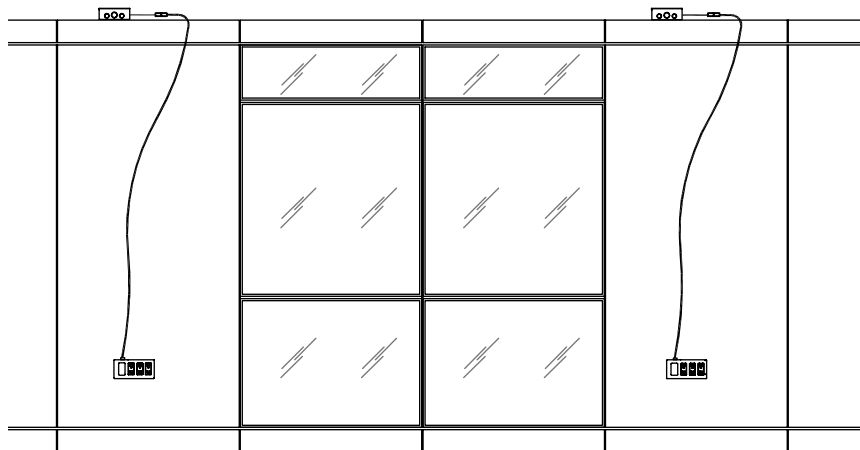

- Each Power Plus Communications Module is individually powered
- The cable is routed directly to the ceiling with a Power Plus Communications Module Starter Cable (ERSC)

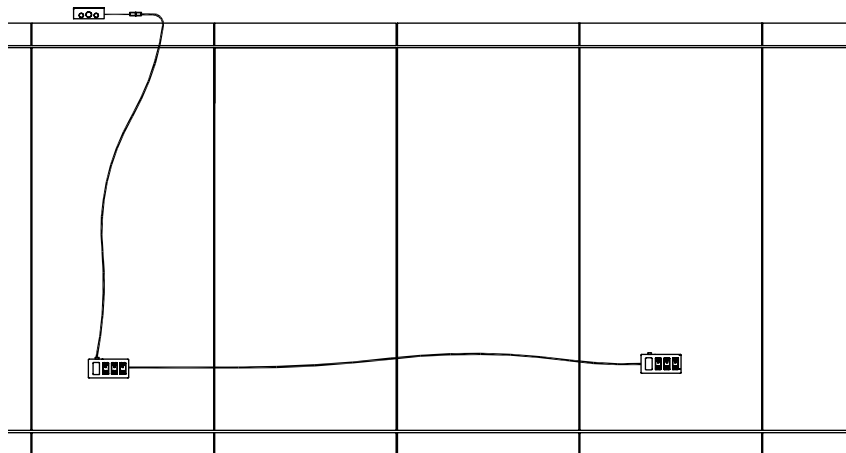

The Power Plus Communications Modules are **not** connected with harnesses

power plus communications module compatibility chart

All Power Plus Communications Modular electrics must be specified according to the wire system in use. The following chart identifies compatibility between Altos Power Plus Communications Modular electrics.

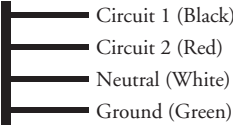
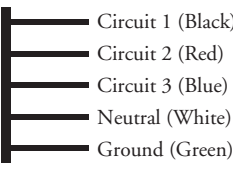
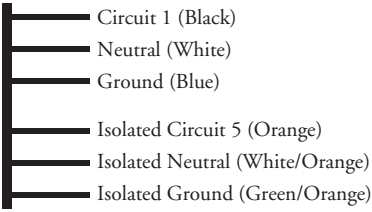
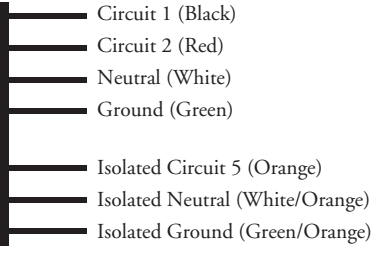
Wire System	Code	No. of Regular Circuits	No. of Isolated Circuits
<p>4-wire</p> 	4B	2	0
<p>5-wire</p> 	5D	3	0
<p>6G-wire, Isolated Ground</p> 	6G	1	1
<p>7-wire, Isolated Ground</p> 	7G	2	1

power plus communications module compatibility chart (continued)

All Power Plus Communications Modular electrics must be specified according to the wire system in use. The following chart identifies compatibility between Altos Power Plus Communications Modular electrics.

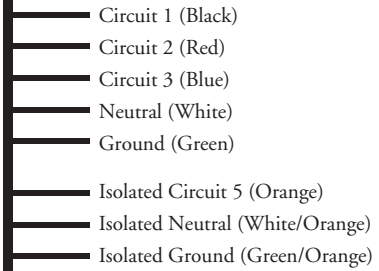
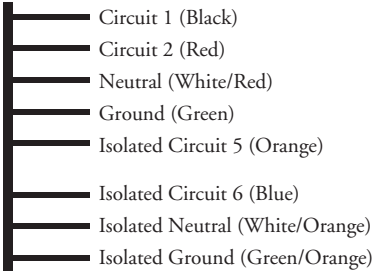
Wire System	Code	No. of Regular Circuits	No. of Isolated Circuits
8-wire, Isolated Ground 	8T	3	1
8-wire, Dual Isolated 	8K	2	2

determining electric & communications requirements

The following steps should be followed when determining electrical requirements.

- The distribution of power is the responsibility of the electrical contractor
- The number of power outlets and voice/data jacks per workspace should be determined by end-user requirements and approved by the electrical contractor
- Voice/data jack/faceplates are supplied by the cable contractor
- Check amperage of specific equipment that will be used. Amperage used below are for sample purposes only

step 1:

List all office equipment and lighting requirements for each work space with appropriate amperage loads. Calculate total amperage required for each work space. Altos receptacles are standard 120-volt, 15 or 20A. 220-volt equipment should be assigned to an alternative electrical distribution system.

Work Space #	Requirement	Amps	Module Required	Type of Circuit	Circuit
1	Personal Computer	4.00			
	Desk Lamp	1.00			
	One Convenience Outlet	4.00			
	Total Amps #1	9 amps			
2	Personal Computer	4.00			
	Desk Lamp	1.00			
	One Convenience Outlet	4.00			
	Total Amps #2	9 amps			
3	Personal Computer	4.00			
	Laser Printer	7.00			
	Desk Lamp x 2	2.00			
	Total Amps #3	13 amps			
	Total Amperage	31 amps			

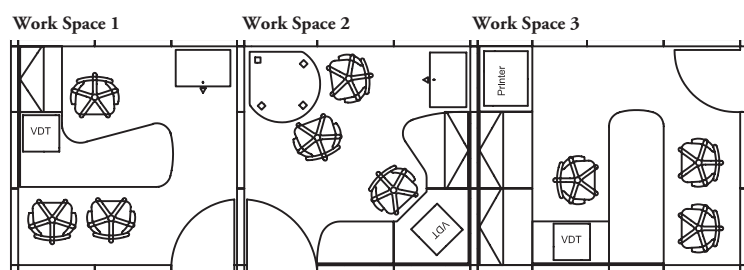

determining electric & communications requirements (continued)

step 2:

Determine the number and location of Receptacle and Communications Modules or Power Boxes needed in each workspace. Some equipment (e.g. computers) may require an isolated circuit and this should be specified at this stage.

Work Space #	Requirement	Amps	Module Required	Type of Circuit	Circuit
1	Personal Computer	4.00	Duplex Receptacle	Isolated Ground or Standard, 120 V, 15 amp	
	Desk Lamp	1.00	Duplex Receptacle	Standard, 120 V, 15 amp	
	One Convenience Outlet	4.00	Duplex Receptacle	Standard, 120 V, 15 amp	
	Total Amps #1	9 amps			
2	Personal Computer	4.00	Duplex Receptacle	Isolated Ground or Standard, 120 V, 15 amp	
	Desk Lamp	1.00	Duplex Receptacle	Standard, 120 V, 15 amp	
	One Convenience Outlet	4.00	Duplex Receptacle	Standard, 120 V, 15 amp	
	Total Amps #2	9 amps			
3	Personal Computer	4.00	Duplex Receptacle	Isolated Ground or Standard, 120 V, 15 amp	
	Laser Printer	7.00	Duplex Receptacle	Standard, 120 V, 15 amp	
	Desk Lamp x 2	2.00	Duplex Receptacle	Standard, 120 V, 15 amp	
	Total Amps #3	13 amps			
Total Amperage		31 amps			

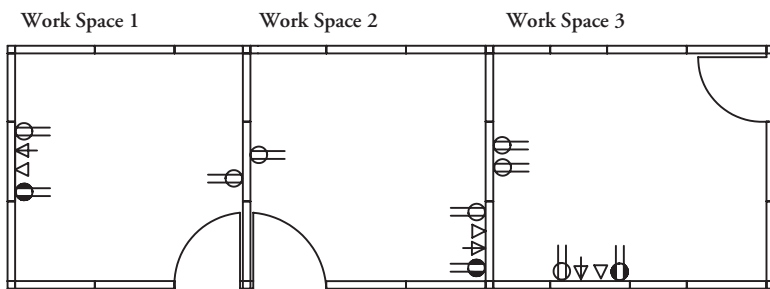

Legend

- Duplex Receptacle, Standard Electrical Outlet 120 volt, 15 or 20 amp
- Duplex Receptacle, Isolated Ground 120 volt, 15 or 20 amp
- Telephone Outlet
- Communications Outlet with Twisted Pair Signal Cable

determining electrics & communications requirements (continued)

The following steps should be followed when determining electrical requirements.

step 3:

Balance the electrical load by assigning equipment to specific circuits. It is necessary to know the building's circuit capacity to do this. Also check local code requirements so that the maximum number of receptacles per circuit is not exceeded.

Work Space #	Requirement	Amps	Module Required	Type of Circuit	Circuit
1	Personal Computer	4.00	Duplex Receptacle	Isolated Ground, 120 V, 15 amp	A
	Desk Lamp	1.00	Duplex Receptacle	Standard, 120 V, 15 amp	B
	One Convenience Outlet	4.00	Duplex Receptacle	Standard, 120 V, 15 amp	B
	Total Amps #1	9 amps			
2	Personal Computer	4.00	Duplex Receptacle	Isolated Ground, 120 V, 15 amp	A
	Desk Lamp	1.00	Duplex Receptacle	Standard, 120 V, 15 amp	C
	One Convenience Outlet	4.00	Duplex Receptacle	Standard, 120 V, 15 amp	C
	Total Amps #2	9 amps			
3	Personal Computer	4.00	Duplex Receptacle	Isolated Ground, 120 V, 15 amp	A
	Laser Printer	7.00	Duplex Receptacle	Standard, 120 V, 15 amp	D
	Desk Lamp x 2	2.00	Duplex Receptacle	Standard, 120 V, 15 amp	D
	Total Amps #3	13 amps			
	Total Amperage	31 amps			

Altos receptacles are decora-style and are rated for 15 or 20 amps. For continuous loads, de-rate load capacity of the circuit to 80% of rating or whats required by local codes. It is advised to consult with local electrician.

step 4:

Determine the number of voice and data jacks required for each workspace. Communication jacks, faceplates and cables are supplied by the cabling contractor

step 5:

Translate electrics and communications requirements into appropriate Altos product

specifying altos electrics & communications

The following steps should be followed when specifying electrics.

- The inside and outside elevations of one wall module can both be installed with Receptacle and/or Communications Modules
- Back-to-back installation of electrics and communications is possible due to offset mounting on Fascias

specifying method

1. Determine Fascia configuration and level of cut out

When power and/or communications is required, Altos Fascias must be specified with corresponding out-outs. Non-powered Fascias can be retrofitted with electrics and communications by ordering a single new Fascia with appropriate cut out(s) and required electrical components.

Work Space 1



Legend

- ⊖ Duplex Receptacle, Standard Electrical Outlet 120 volt, 15 amp or 20 Amp
- ⊖ Duplex Receptacle, Isolated Ground 120 volt, 15 amp or 20 Amp
- ◁ Telephone Outlet

On Elevation Y, build up Fascias and specify electrics and communications option at worksurface height for Fascia (FPW12)

On Elevation Z, build up a Fascias and specify electrics and communications option at 18" height for Fascias (FPW13, FPW14, FPW15)

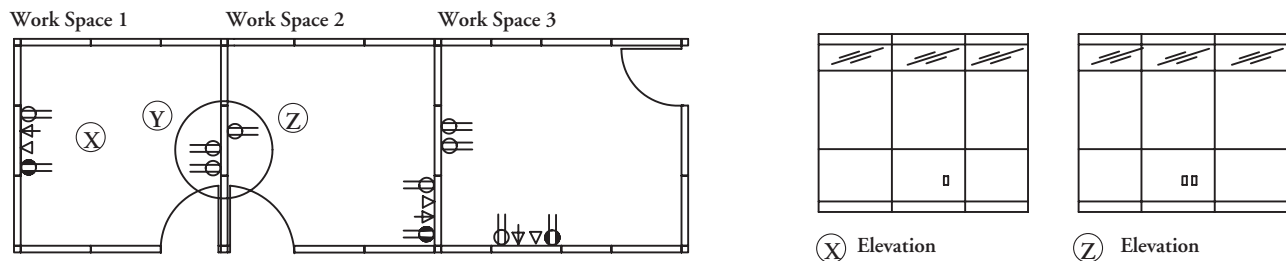

2. Order appropriate Receptacle and/or Communications Module(s) or Power Boxes. The total number should match the total number of cut outs specified on Fascias

portrait – mounted
storage & accessories

portrait – mounted storage & accessories

PLANNING WITH MOUNTED STORAGE	172
ACCESSORY BASICS	173
PLANNING WITH ACCESSORIES	173
LOAD RESTRICTIONS.	174

planning with mounted storage

A number of mounted storage products can be suspended on Altos Portrait walls. Mounted storage products conserve floor space and provide storage for materials.

Overhead Cabinets are suspended by two brackets that hook into the Vertical Post Packages, so all applications must be on-module and span the width of the wall module

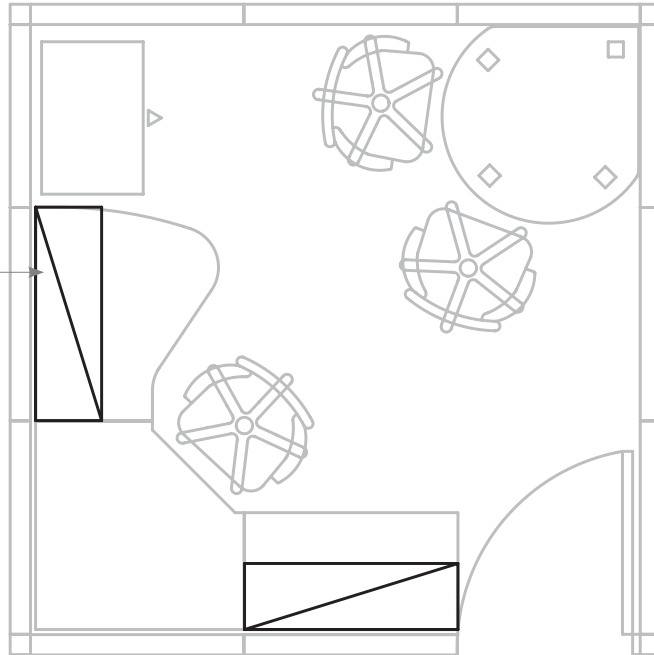

The following overheads are available for mounting to Altos Portrait (these overheads are not compatible with Altos Landscape):

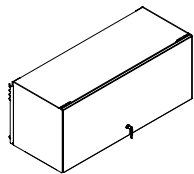

Standard Overhead Cabinet (LCSF)

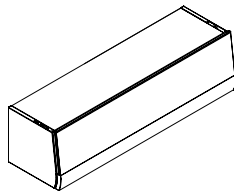

Ledger Overhead Cabinet (LUSF)

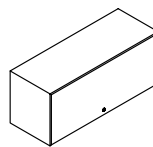

Ledger Flush-Front Cabinet (LSF)

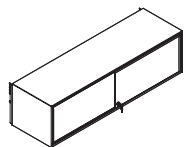
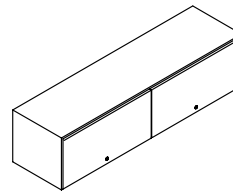

Ledger Sliding Door Cabinet (LSSF)

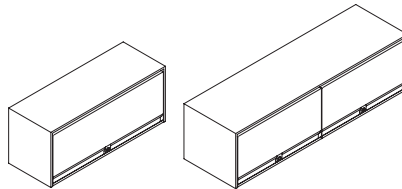

Ledger Full Pull Cabinet (SSF)

Altos Portrait offers the following mounted storage and accessory options.

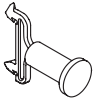

Coat Hook (FMCH)

- Allows a means of hanging coats within an Altos environment
- Mounted on-module, in the vertical reveal at varying heights
- Can be used for all wall elevation and surface finish types

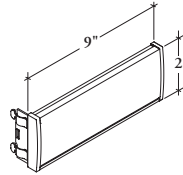

Office Signage (FMOS)

- Identifies an occupant and/or location, within an Altos environment
- Coordinates with the Workstation Signage on systems furniture
- Mounted on-module, in the vertical reveal at varying heights
- Can be used for all wall elevation and surface finish types

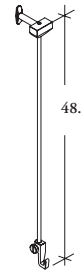

Art Hook (FMAH)

- Provides an alternative means of hanging pictures without damaging the face of Altos fascias
- Mounted off-module, from the horizontal reveal line above the location of the art work
- Can be used for all wall elevation and surface finish types
- Each hook can support a picture weighing up to 15 lbs
- Multiples of the Art Hook can be used to accommodate large, unbalanced or heavy pictures

planning with accessories

The following rules apply when planning with accessories.

The Art Hook **cannot** be mounted from the reveal lines of the Barn Door or Adjustable Wall End

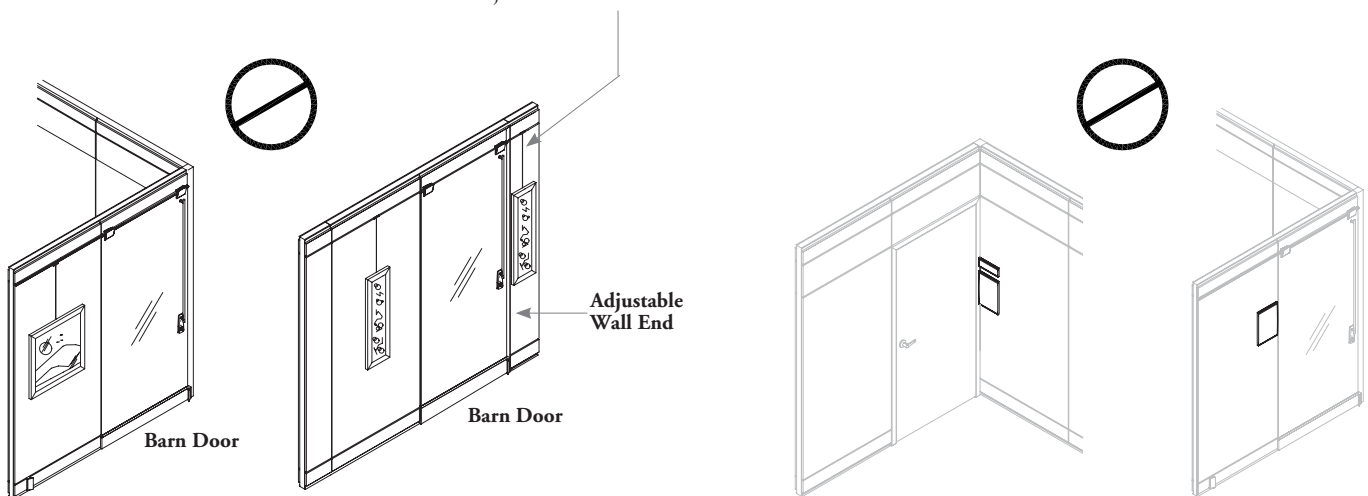

Art Hook (FMAH) & Coat Hook (FMCH)

- Is not advised to mount a picture at a location that interferes with a swinging door in the open position
- Must be located in a position that does not interfere with the path of the Barn Door

Office Signage (FMOS)

- **Cannot** be mounted at the inside location of corner connections
- Must be located in a position that does not interfere with the path of the Barn Door

load restrictions

single-sided applications per portrait wall module

These four applications can be planned in any combination on up to a 16' wall run.

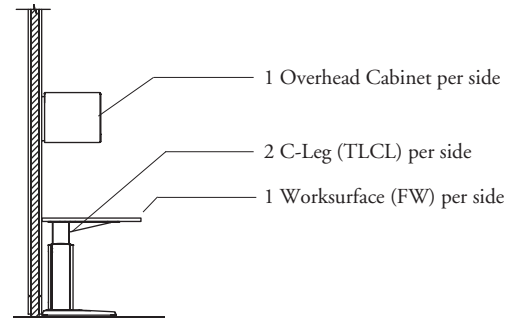
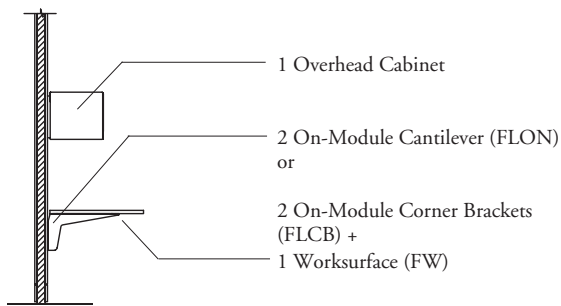
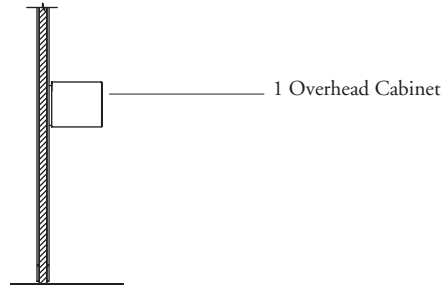
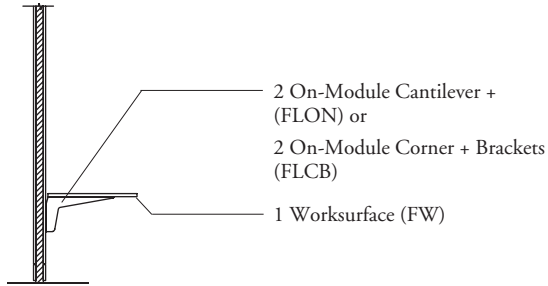

portrait – integration

portrait – integration

INTEGRATION OVERVIEW	179
PLANNING WITH WORKSURFACES	180
PLANNING WITH SUPPORTS	183
PLANNING WITH A SEAMLESS COLOR WORKSURFACE	185

Altos Portrait integrates with other freestanding Teknion desking and table lines.

Worksurfaces must be mounted on-module, with Altos specific brackets.

perpendicular to the wall

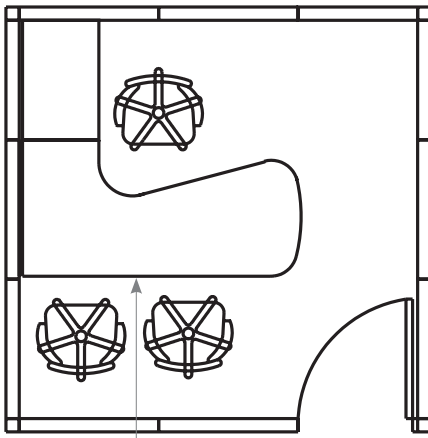

On-Module Worksurface

parallel to the wall

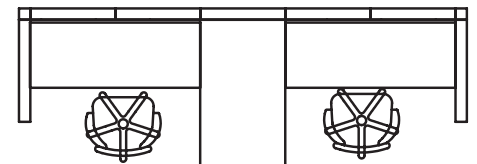

On-Module Worksurface

combination

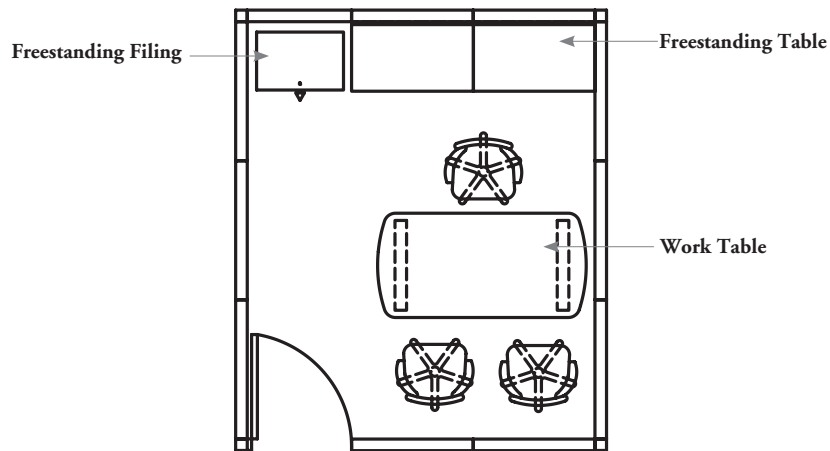

in a corner

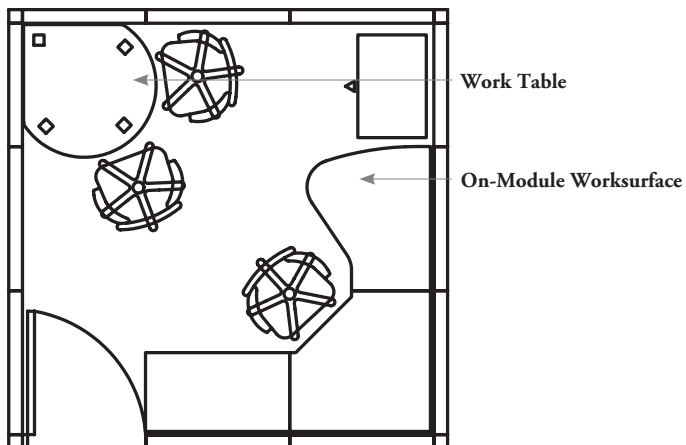

freestanding

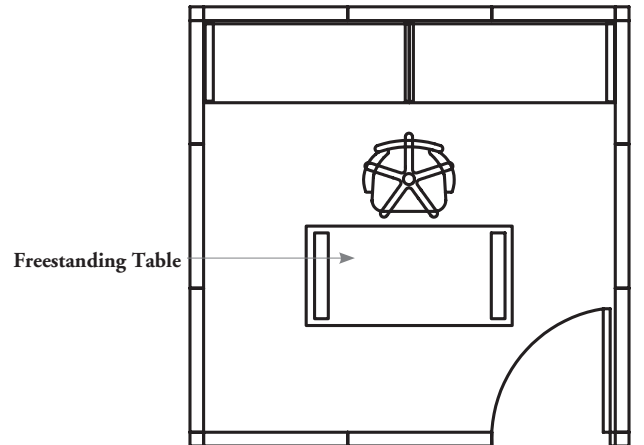

planning with worksurfaces

The following rules should be taken into consideration when planning with worksurfaces.

For typical seated working conditions, a 29" worksurface height above the finished floor is recommended. The 42" worksurface height is recommended for a standing-height worksurface.

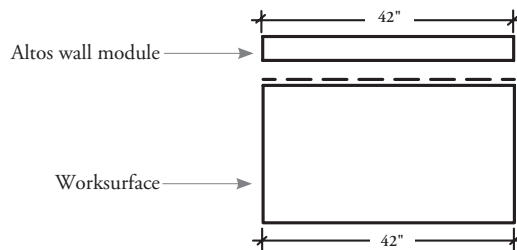
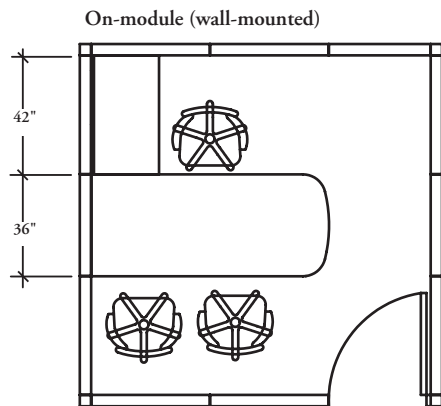

All worksurfaces, wall-mounted and semi-suspended, must be on-module because the surfaces are suspended from the slotted standards on the Vertical Post Packages between the fascias

If off-module planning is required, Worksurfaces, Case Goods or Tables can be used in freestanding applications to allow for a variety of functional applications

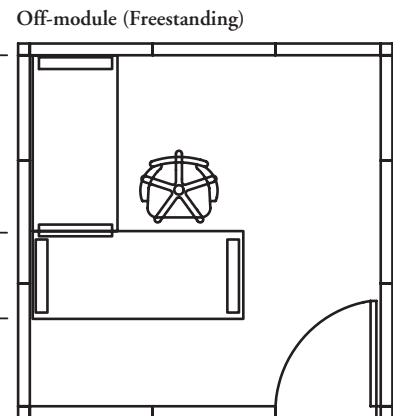

Specify one On-Module Cantilever (FLON) for each worksurface where height changes are greater than 1" to ensure sufficient support

- Mounting heights can vary between worksurfaces that are adjacent or perpendicular to one another
- At the point of height transition (greater than 1"), supports **cannot** be shared

Worksurface mounted 33" above the finished floor

Worksurface mounted 29" above the finished floor

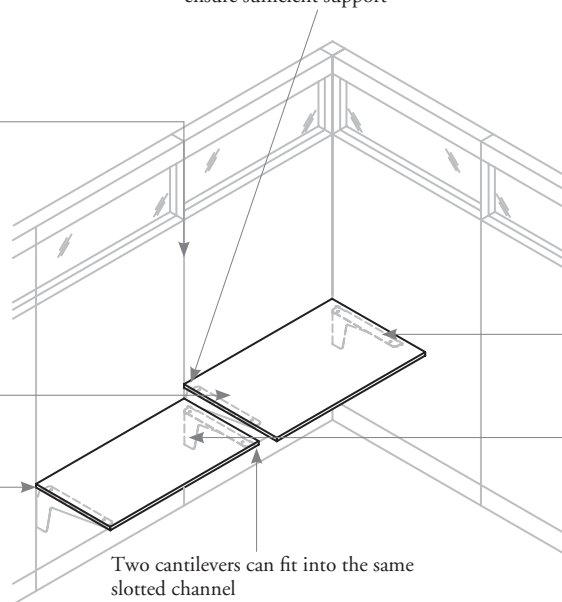

On-Module Cantilever
On-Module Cantilever The slotted standards in the Vertical Post Packages allow worksurfaces to be fully- or semi-suspended at any height in 1" increments

On-Module Cantilever

planning with worksurfaces (continued)

The following should be taken into consideration when planning with worksurfaces.

parallel applications

The parallel applications width of the worksurface must be the same as the width of the corresponding wall module – the only exception is where one worksurface spans the width of two (2) wall modules. A worksurface **cannot** span a width greater than two wall modules

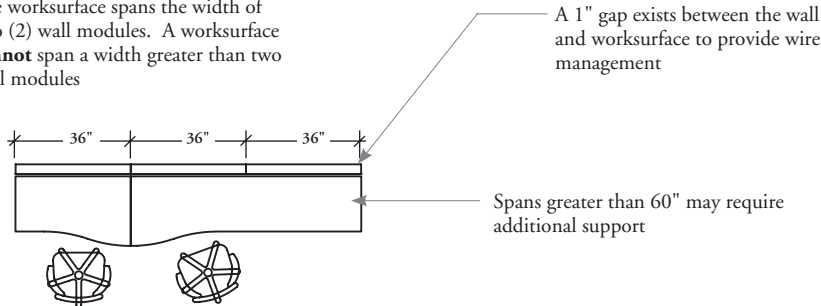

corner applications

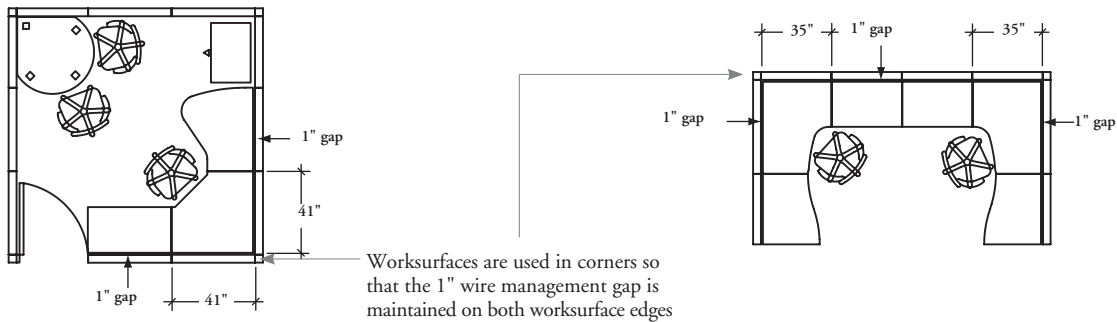

perpendicular applications

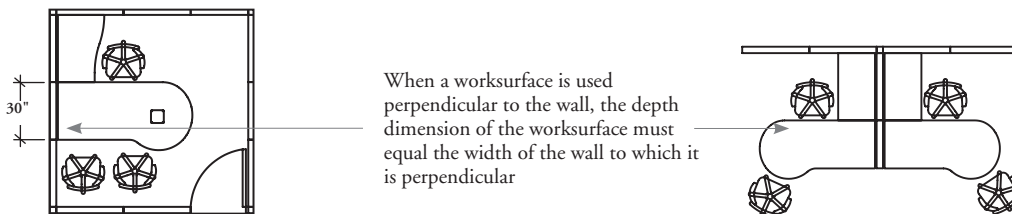

planning with worksurfaces (continued)

The following rules should be taken into consideration when planning with worksurfaces.

u-shaped configurations

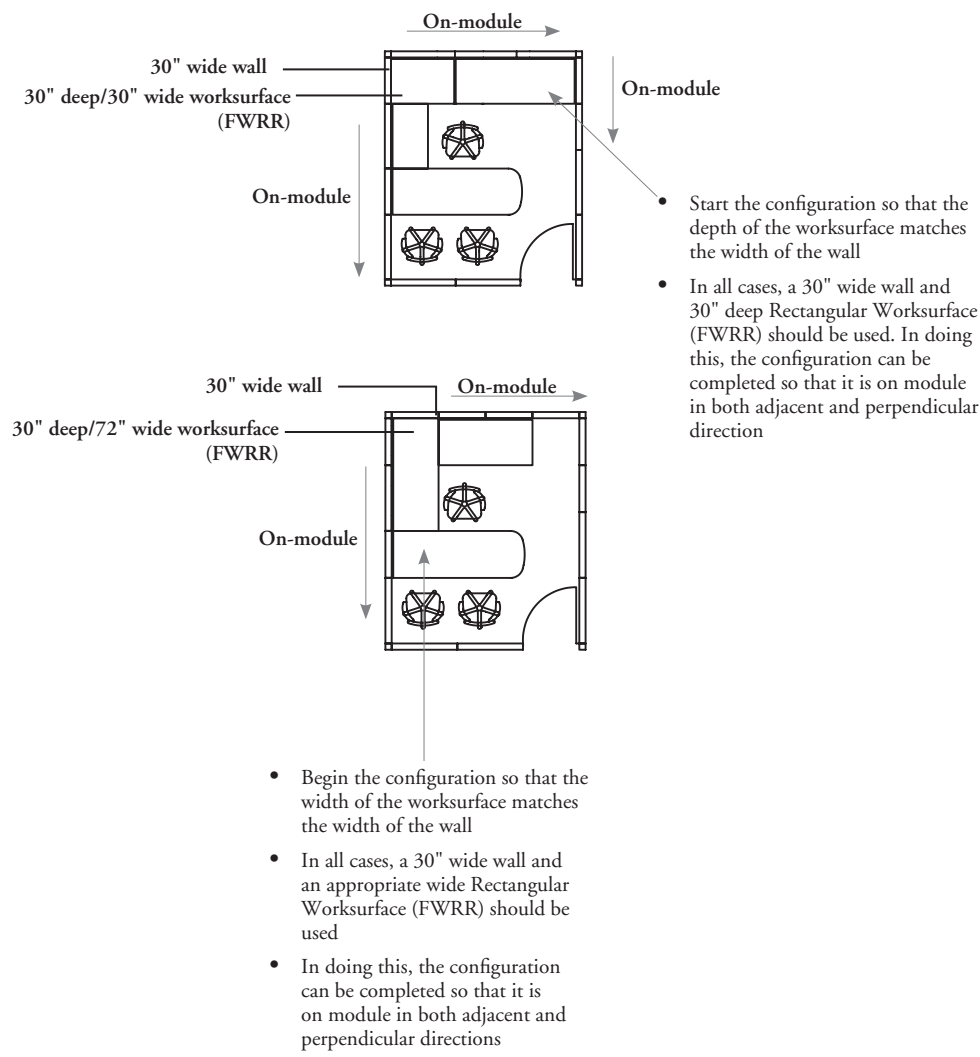

freestanding configurations

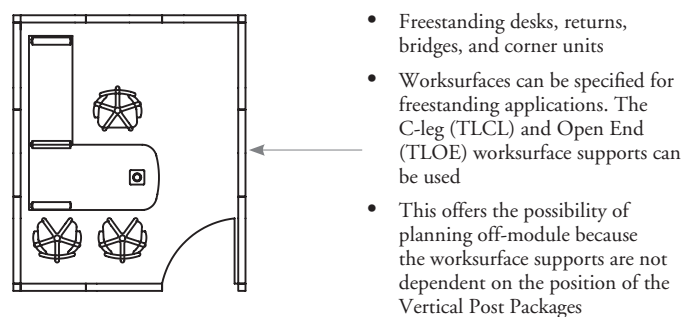

planning with supports

Two worksurfaces supports are available for mounting on- module surfaces to Altos; the On- Module Cantilever (FLON) and the On- Module Corner Bracket (FLCB).

on-module supports

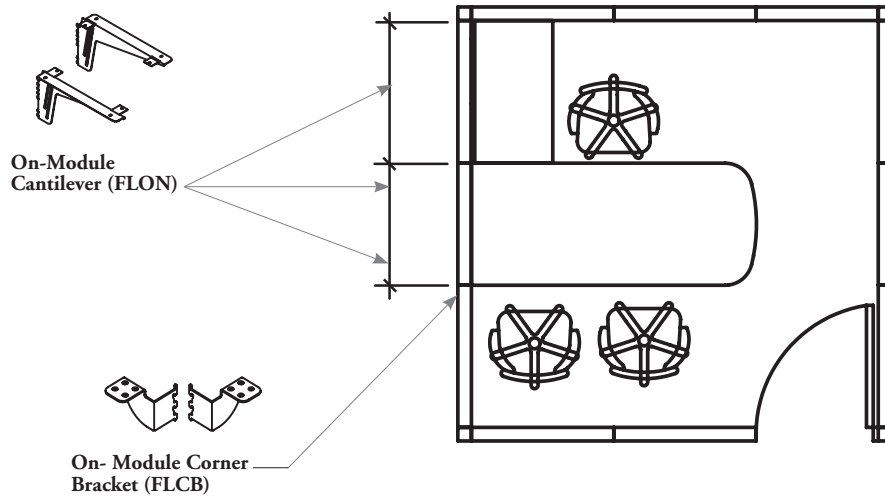

- Worksurface supports must be on-module when used in fully- or semi-suspended applications
- Visually, this lines the worksurface up with the reveals of the wall to provide line continuity from the vertical to the horizontal plane
- Supports can be used on-module only

off-module supports

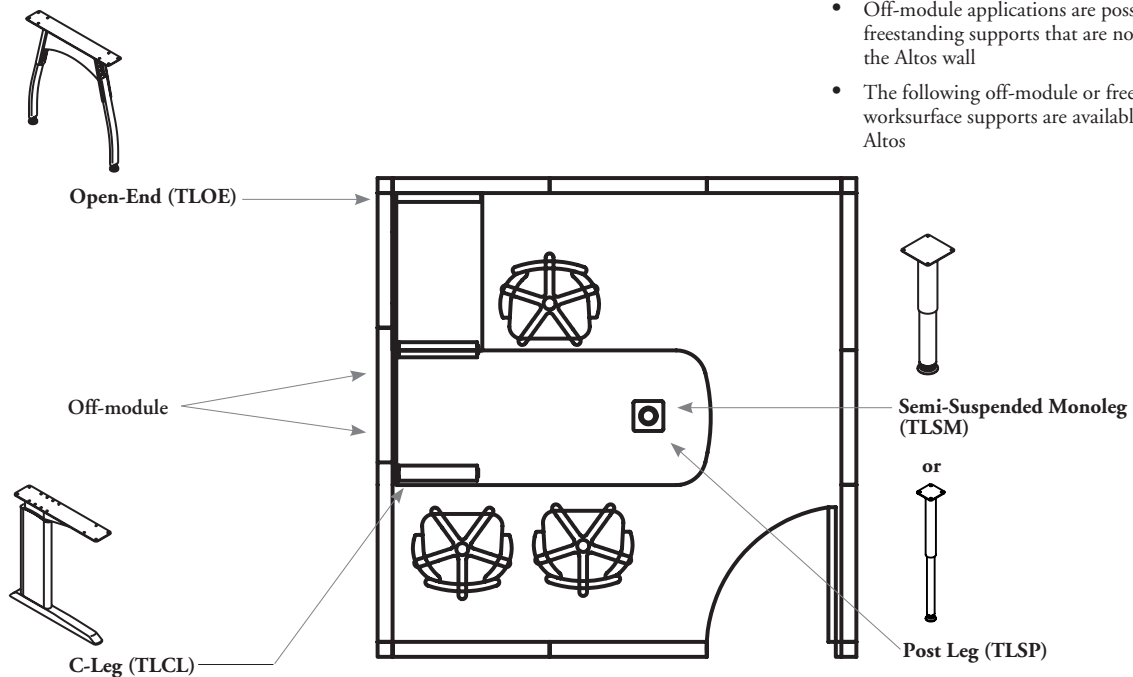

- Off-module applications are possible using freestanding supports that are not attached to the Altos wall
- The following off-module or freestanding worksurface supports are available for use with Altos

planning with supports (continued)

The following are typical examples of the supports that would be used for mounting worksurfaces.

One support is required at the end of each worksurface. Some supports can be shared between two adjacent worksurfaces.

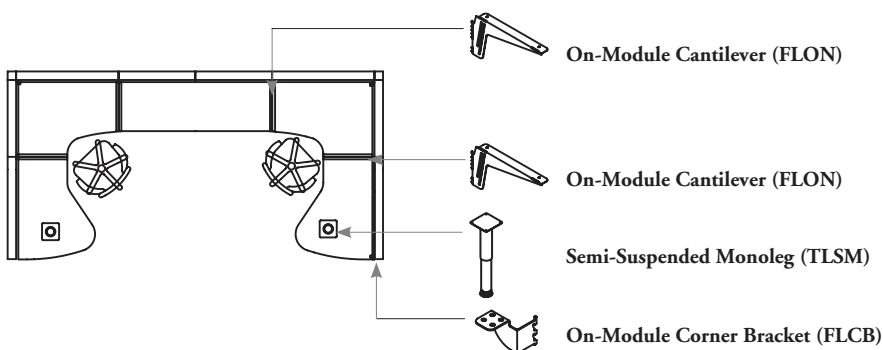
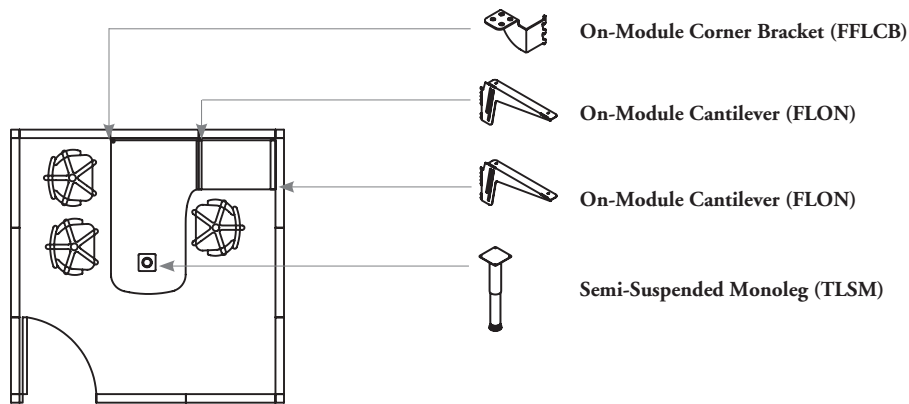

Wall-mounted worksurfaces require support every 60".

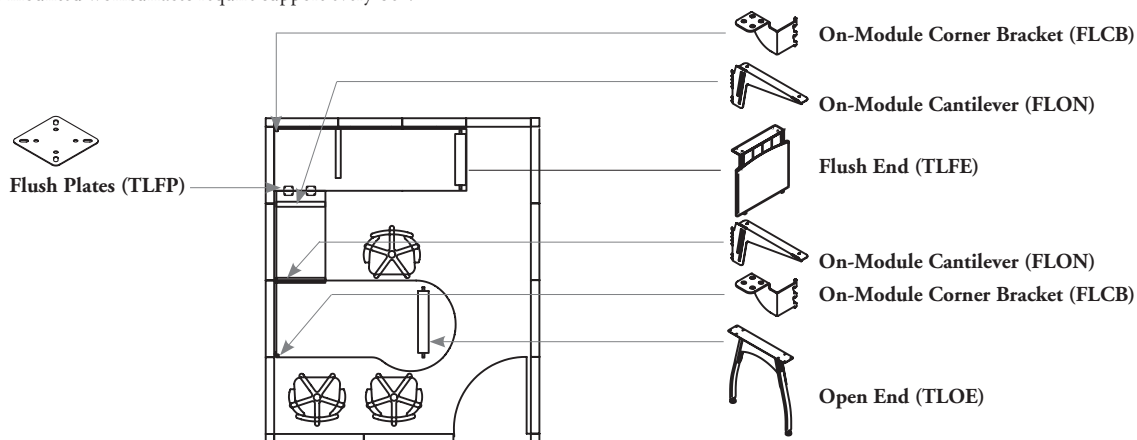

planning with a seamless color worksurface

The following should be considered when planning with seamless worksurfaces.

Centered Support Beam without storage

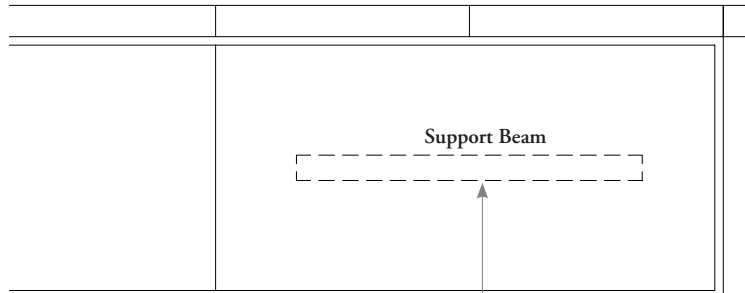

All Seamless Color Worksurfaces with widths greater than 48, will be accompanied by a support beam with mounting hardware

Adjusted Support Beam with storage

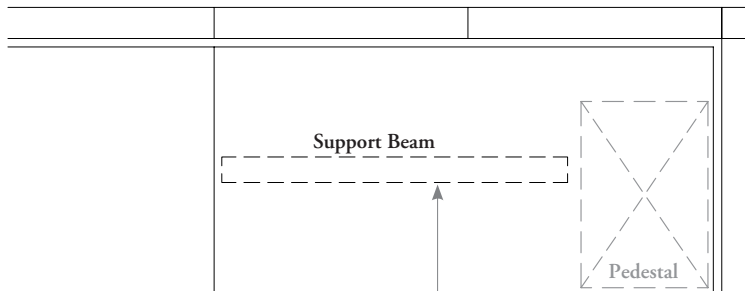

The beam can be fitted to the left or right when applying pedestal storage underneath

understanding landscape

understanding landscape

OVERVIEW – LANDSCAPE	188
PLANNING POSSIBILITIES – ENCLAVES – LANDSCAPE	189
PLANNING POSSIBILITIES – OFFICE – LANDSCAPE.	193
PLANNING POSSIBILITIES – MEETING ROOM – LANDSCAPE . . .	194
PLANNING POSSIBILITIES – STOREFRONT – LANDSCAPE	195

overview – landscape

Altos Landscape is a full height architectural wall system with horizontally spanning fascias and a variety of wall-mounted components for increased functionality. Landscape walls provide an efficient, flexible and acoustically sound solution for both large and small enclosed spaces.

- Landscape fascias are available in a wide variety of materials and functional capability, such as the Metal Micro Perforated and Acoustic Tackable Fabric fascias for enhanced acoustics
- The Landscape wall-mounted collection includes Shelving, Lighting, and Storage, which maximize available floor space and enable flexible planning opportunities
- The collection includes a wall integrated height-adjustable desk for sit-stand applications



Planning with Altos Landscape maximizes the space on a floor plate to fit more offices in a run. This is accomplished by planning with Landscape's large horizontal fascias and the wall integrated Landscape desk, shelving, lighting and storage collection.

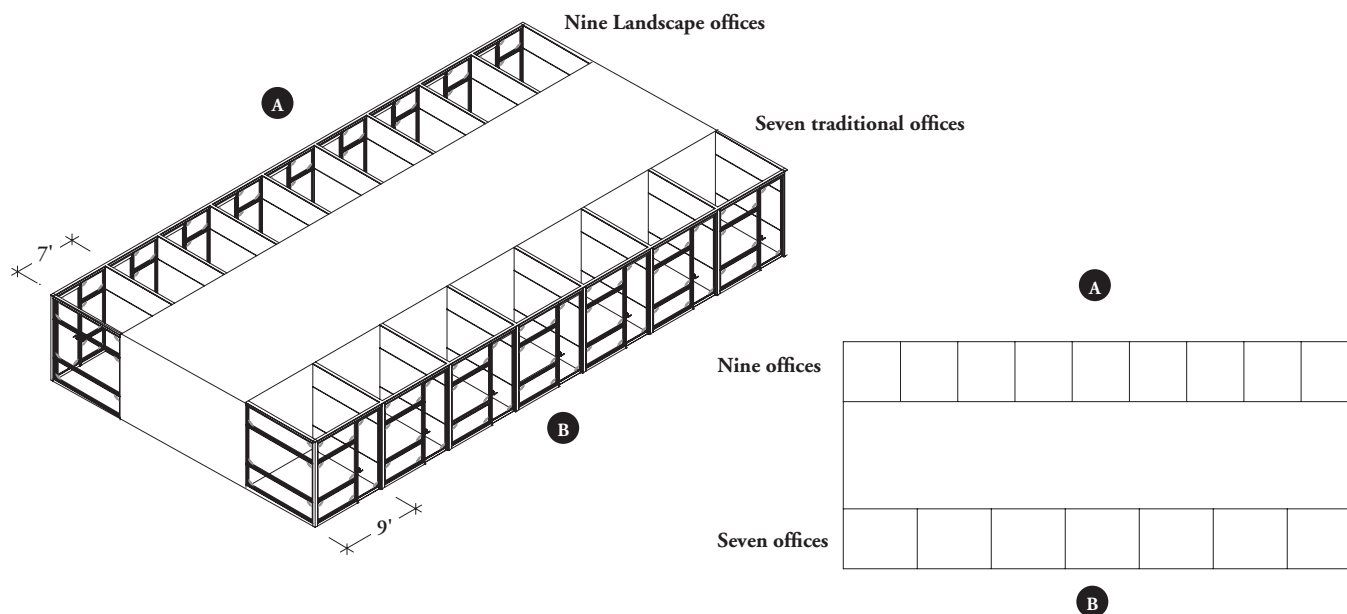

planning possibilities – enclaves – landscape

Landscape Fascias provide functionality to enclosed spaces and provide enhanced acoustics.

enclaves

Landscape enclaves are small retreat spaces beneficial for a call, two to three person collaboration or a heads down space to work alone.

- Allows for one to three people depending on layout
- Can be planned with a footprint as small as 5' x 7'

Primary enclave applications include:

- 1 Heads down work
- 2 Collaboration
- 3 Video conferencing

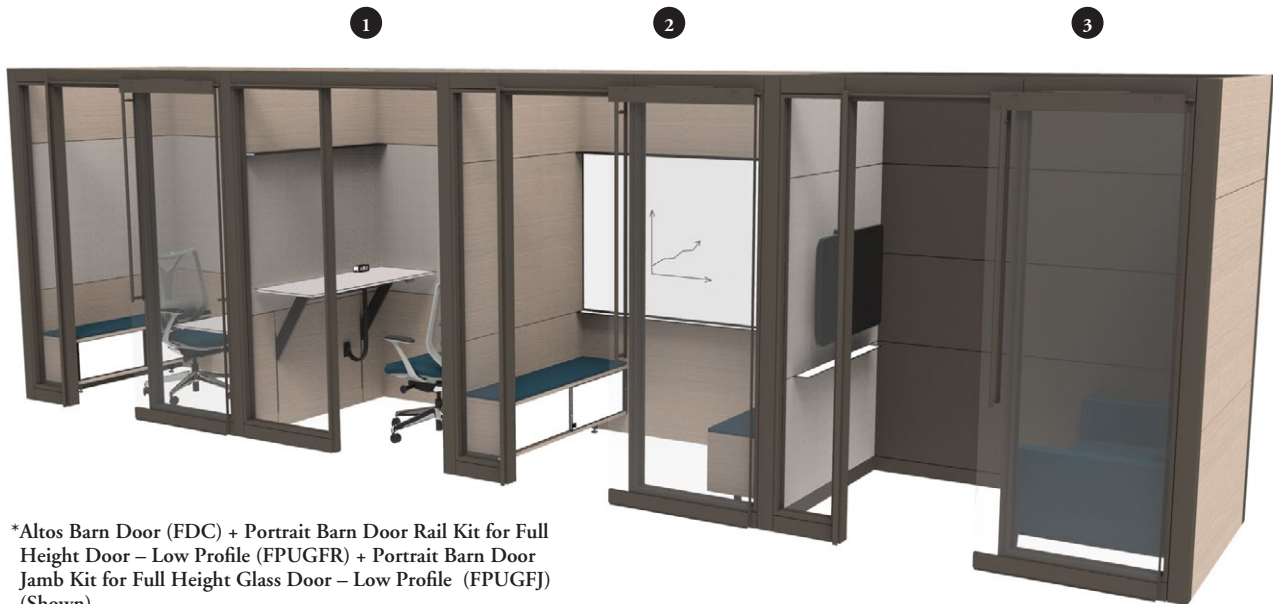

*Altos Barn Door (FDC) + Portrait Barn Door Rail Kit for Full Height Door – Low Profile (FPUGFR) + Portrait Barn Door Jamb Kit for Full Height Glass Door – Low Profile (FPUGFJ) (Shown)

landscape planning possibilities – enclaves (continued)

enclaves - work

- Ideal as a single person work space retreat for heads down work
- Acoustic Tackable Fabric fascia provides acoustic sound absorption and tackable functionality
- Altos desk height can be adjusted to the required ergonomic height for sitting or standing

Commonly used in combination with the following components:

- 1 Landscape Desk Height-Adjustable
- 2 Landscape Solid fascias
- 3 Acoustic Tackable Fabric fascias
- 4 Landscape Wall-Mounted Light

Not Shown:

- Power Cube
- Power and Communication electrics



landscape planning possibilities – enclaves (continued)

enclaves - collaboration

- Ideal as a two person collaborative space
- Backpainted Whiteboard and Tray provides functionality for brainstorming and project planning
- Landscape Wall-Mounted Light above Whiteboard can be specified with adjustable task lighting for the necessary work style required

Commonly used in combination with the following components:

- 1 Landscape Wall-Mounted Cabinets
- 2 Fitted Seat Cushion
- 3 Landscape Solid Fascias
- 4 Whiteboard Frameless Fascias
- 5 Landscape Tray Whiteboard
- 6 Landscape Wall-Mounted Light

Not Shown:
Power and Communication electrics



landscape planning possibilities – enclaves (continued)

enclaves - video conferencing

- Ideal as a personal video conferencing enclave or a retreat to relax and unwind
- Metal Micro Perforated fascias provide acoustic sound absorption for additional privacy
- Monitor technology shown below is ideal for video sharing applications

Contact your Teknion service representative for use of monitor with Landscape

Commonly used in combination with the following components:

- 1 Landscape Micro Perforated fascias
- 2 Landscape Solid Fascias
- 3 Landscape Tray Whiteboard

Not Shown:
Power and Communication electrics



planning possibilities – office – landscape

office

- Landscape's wall-integrated Office format makes more efficient use of available space while maintaining acoustic isolation
- Fixed or non fixed address applications for one to three people
- Can be planned with a footprint as small as 7' x 9'

Commonly used in combination with the following components:

- 1 Landscape Desk Height-Adjustable
- 2 Landscape Wall-Mounted Sliding Door Cabinet
- 3 Fitted Seat Cushion
- 4 Landscape Wall-Mounted Light
- 5 Landscape Acoustic Tackable Fabric fascias
- 6 Landscape Solid Fascias
- 7 Power Cube

Not Shown:

Worksurface Grommet
Power and Communication electrics



planning possibilities – meeting room – landscape

meeting room

- Large environments are optimized for boardroom meetings, educational training sessions or special events
- Ideal for five to twenty people depending on layout
- Maximum wall run for Landscape fascias is 16' when planning with shelving or Wall-Mounted Light
- Landscape's variety of functional fascias can provide transparency for light transmission, sound absorption or isolation, and Whiteboard and Tackboards for project planning
- Storage can be optimized as housing for AV equipment or additional bench seating
- Wall-Mounted Whiteboard Tray used below Whiteboard or monitors

Commonly used in combination with the following components:

- 1 Landscape Wall-Mounted Cabinets
- 2 Landscape Whiteboard fascias
- 3 Landscape Tray Whiteboard
- 4 Landscape Single or Double Glass fascias
- 5 Landscape Solid fascias
- 6 Acoustic Tackable Fabric Fascia

Not Shown:

- Fitted Seat Cushion
- Power and Communication electrics

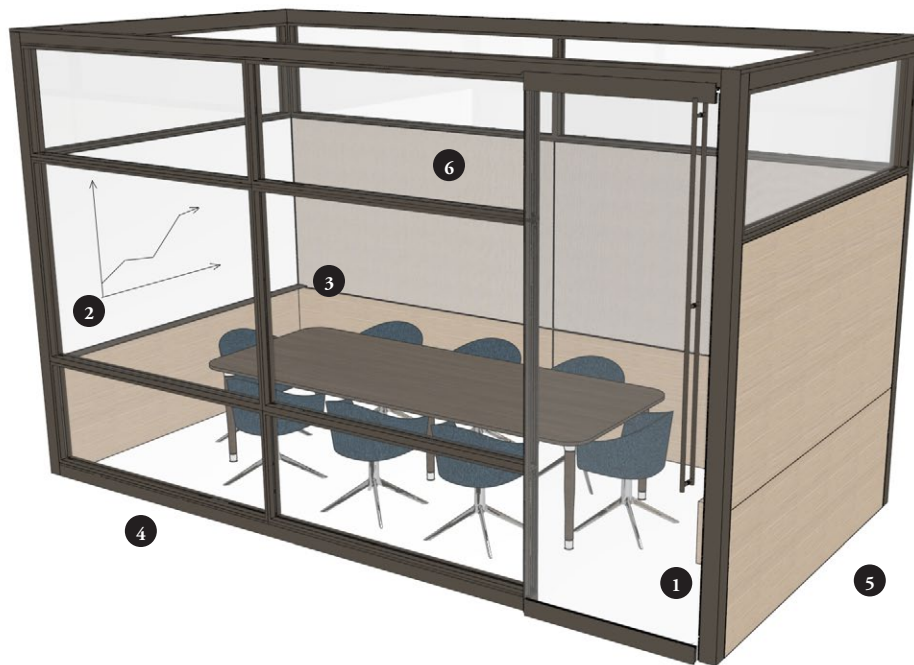

planning possibilities – storefront – landscape

storefront

- Large horizontal glass fascias emphasize a continuous landscape aesthetic
- Single or Double Glass
- Transitions to select Altos doors, with Hinge, Pivot and Barn Door options
- Integrates with Altos shelving and light program

Commonly used in combination with the following components:

- 1 Landscape Wall-Mounted Light
- 2 Landscape Single or Double Glass fascias
- 3 Select Altos Hinged, Pivot and Barn Doors



landscape – fascias

landscape – fascias

UNDERSTANDING FASCIAS – LANDSCAPE	199
FASCIA ELEVATION OVERVIEW – LANDSCAPE	200
FASCIA ELEVATION BASICS – LANDSCAPE	201
JUSTIFIED FASCIA OVERVIEW – LANDSCAPE	202
JUSTIFIED FASCIA ELEVATION BASICS – LANDSCAPE	203
DESK FASCIA BASICS – LANDSCAPE	204
FASCIA FINISHES – LANDSCAPE	205
SPECIFYING FASCIA HEIGHTS – LANDSCAPE	210
PLANNING WITH FASCIAS – LANDSCAPE	211
PLANNING WITH FASCIA WIDTHS – LANDSCAPE	213
PLANNING WITH ACOUSTIC TACKABLE & FABRIC WRAPPED FASCIAS – LANDSCAPE	214
FASCIA POWER/COMMUNICATION CUT OUTS – LANDSCAPE	215
CLERESTORY BASICS – LANDSCAPE	216
PLANNING WITH CLERESTORY – LANDSCAPE	217
FILLER PANEL BASICS – LANDSCAPE	219
ALUMINUM FASCIA KIT BASICS – LANDSCAPE	220

understanding fascias – landscape

Landscape Fascias can be planned in six elevations for various datum combinations.

The following chart outlines the Landscape elevations offered.

Standard Working Wall

- Shares 36" and 84" high datums with Portrait elevations
- Can accommodate Wall-Mounted Light and Shelving
- Base/Ceiling Fascias are 4" high

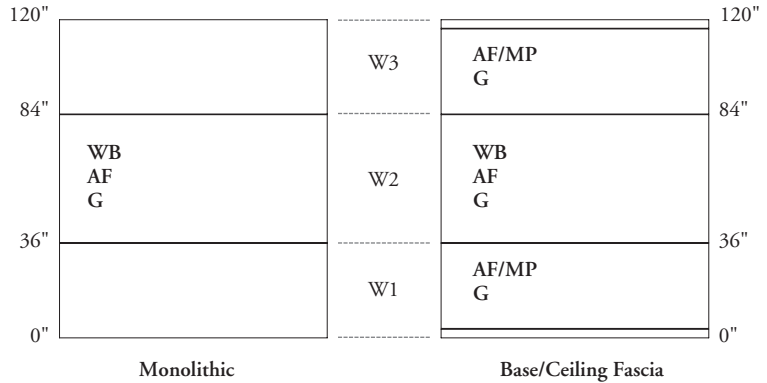

Light Working Wall

- Can accommodate Wall-Mounted Light and Shelving
- Allows for 36", 60" and 84" datums
- Base/Ceiling Fascias are 4" high

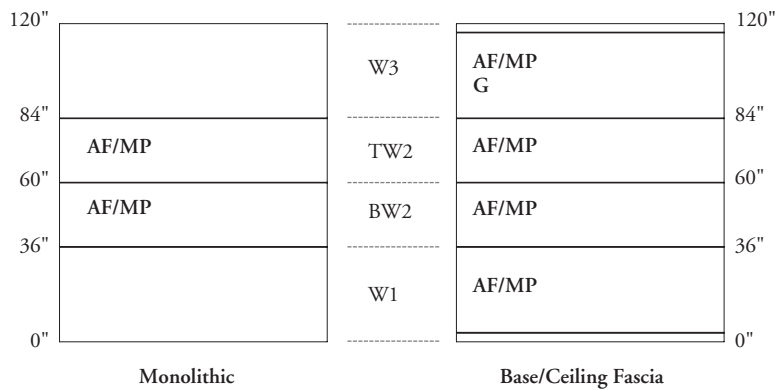

Cabinet Working Wall

- Can accommodate wall-mounted cabinets, shelving and lighting.
- Allows for 21", 36", and 84" datums
- Base/Ceiling Fascias are 4" high

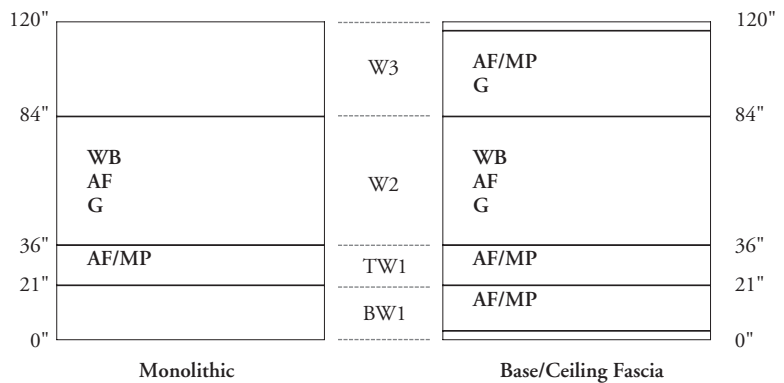

Legend:

code	description	width range
S	Solid (available on all fascias)	12" - 120"
FW	Fabric Wrapped (available on all fascias)	12" - 120"
WB	Whiteboard Framed	12" - 118"
WB	Whiteboard Frameless	12" - 96"
AF	Acoustic Tackable Fabric	12" - 120"
MP	Metal Micro Perforated	12" - 96"
G	Glass	12" - 96"

fascia elevation overview – landscape

Landscape Fascias are used to create the faces of Altos walls and are configured into six elevations depending on the Fascia selection.

- Fascias are available in a variety of solid and glass finishes that correspond to the selected landscape elevation
- Landscape elevations are built up out of fascias and frames to complete both sides of a wall module
- Landscape elevations can be different on the front and back of the wall
- Power and communication receptacle cut outs can be specified with select solid and fabric wrapped Fascias
- Walls must be installed from floor to ceiling
- Acoustic Fascias are not available for base, ceiling, WM1, or WM3 locations; use Fabric Wrapped fascias in these applications
- Landscape Base and Ceiling Fascias are 4" high
- Select Landscape Fascias are available in widths from 12" – 120" in 1/8" increments

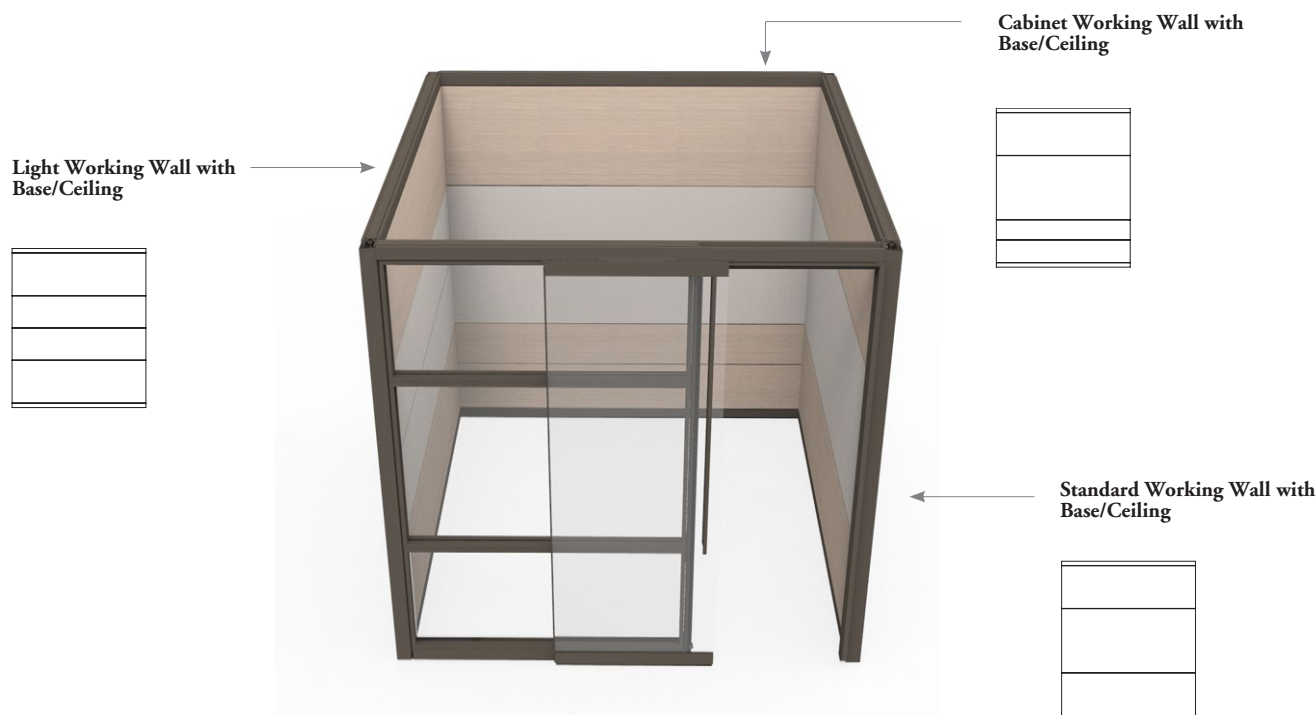

Altos Landscape works with some Altos Portrait components to create a complete wall solution. For full details on these components please refer to the Altos Portrait section.

Also available but Not Shown:

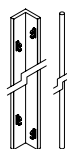

Two-Way 90° Corner Cover (FKCN90)

Provides the full-height trim for two walls connected at 90° at Two-Way Connection 90° Corner

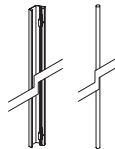

Two-Way 120° Corner Cover (FKCN120)

Provides the full-height trim for two walls connected at 120°



Two-Way 135° Corner Cover (FKCN132)

Provides a full-height trim for two walls connected at 135°



Three-Way 135° Corner Cover (FKCN133)

Provides a full-height trim for three walls connected at 135°



Three-Way 180° Corner Cover (FKCN180)

Provides the full-height trim for three walls connected at 180°

fascia elevation basics – landscape

Altos Landscape fascia options include Solid, Glass, Whiteboard, Fabric-Wrapped, Acoustic Tackable Fabric, and Acoustic Metal Micro Perforated. Fascias can be reconfigured to other fascia types after installation without modifying the interior wall structure.

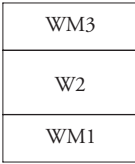
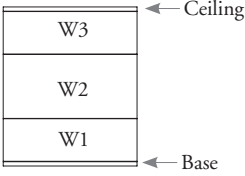
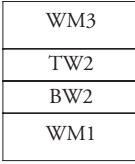
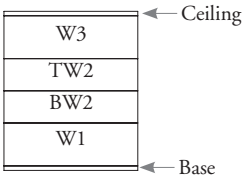
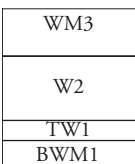
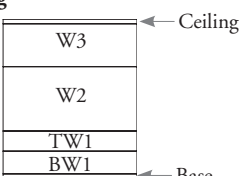
Landscape Arrangement	Fascias Available
<p>Standard Working Wall Monolithic</p> 	<ul style="list-style-type: none"> • WM3 FLWM3 and FLRWM3 are 12 - 36" high in 1" increments to accommodate ceiling height • W2 FLW2, FLRW2, FLATW2, FLMWN, FLMMF, FLGC, FLGD are 48" high • WM1 FLWM1 and FLRWM1 are 36" high
<p>Standard Working Wall Base/Ceiling</p> 	<ul style="list-style-type: none"> • Ceiling FLC is 4" high and available in Solid, Fabric Wrapped, Anodized and Painted • W3 FLW3, FLRW3, FLATW3, FLMPW3, FLMBW3, FLGC and FLGD are 12 - 32" high in 1" increments to accommodate ceiling height • W2 FLW2, FLRW2, FLATW2, FLMWN, FLMMF, FLGC and FLGD are 48" high • W1 FLW1, FLRW1, FLATW1, FLMPW1, FLMBW1, FLGC and FLGD are 32" high • Base FLB is 4" high and available in Solid, Fabric Wrapped, Anodized and Painted
<p>Light Working Wall Monolithic</p> 	<ul style="list-style-type: none"> • WM3 FLWM3 and FLRWM3 are 12 - 36" high in 1" increments to accommodate ceiling height • TW2 FLTW2, FLRTW2, FLATTW2, FLMPW2 and FLMBTW2 are 24" high • BW2 FLBW2, FLRBW2, FLATBW2, FLMPBW2 and FLMBBW2 are 24" high • WM1 FLWM1 and FLRWM1 are 36" high
<p>Light Working Wall Base/Ceiling</p> 	<ul style="list-style-type: none"> • Ceiling FLC is 4" high and available in Solid, Fabric Wrapped, Anodized and Painted • W3 FLW3, FLRW3, FLATW3, FLMPW3, FLMBW3, FLGC and FLGD are 12 - 32" high in 1" increments to accommodate ceiling height • TW2 FLTW2, FLRTW2, FLATTW2, FLMPW2 and FLMBTW2 are 24" high • BW2 FLBW2, FLRBW2, FLATBW2, FLMPBW2 and FLMBBW2 are 24" high • W1 FLW1, FLRW1, FLATW1, FLMPW1, FLMBW1, FLGC and FLGD are 32" high • Base FLB is 4" high and available in Solid, Fabric Wrapped, Anodized and Painted
<p>Cabinet Working Wall Monolithic</p> 	<ul style="list-style-type: none"> • WM3 FLWM3 and FLRWM3 are 12 - 36" high in 1" increments to accommodate ceiling height • W2 FLW2, FLRW2, FLATW2, FLMWN, FLMMF, FLGC and FLGD are 48" high • TW1 FLTW1, FLRTW1, FLATTW1, FLMPW1 and FLMBTW1 are 15" high • BWM1 FLBWM1 and FLRBWM1 are 21" high
<p>Cabinet Working Wall Base/Ceiling</p> 	<ul style="list-style-type: none"> • Ceiling FLC is 4" high and available in Solid, Fabric Wrapped, Anodized and Painted • W3 FLW3, FLRW3, FLATW3, FLMPW3, FLMBW3, FLGC and FLGD are 12 - 32" high in 1" increments to accommodate ceiling height • W2 FLW2, FLRW2, FLATW2, FLMWN, FLMMF, FLGC and FLGD are 48" high • TW1 FLTW1, FLRTW1, FLATTW1, FLMPW1 and FLMBTW1 are 15" high • BW1 FLBW1, FLRBW1, FLATBW1, FLMPBW1 and FLMBBW1 are 17" high • Base FLB is 4" high and available in Solid, Fabric Wrapped, Anodized and Painted

justified fascia overview – landscape

Landscape Justified Fascias are used when a Landscape Desk is justified left or right on the wall module. They are specified at the W2, W3 and Base and Ceiling fascia locations.

When a desk is specified justified left or right on the wall module the upper fascias must be specified as Landscape justified fascias to avoid interference with the Landscape Desk Frame (FLDF). Justified Fascias are not required at the W1 location. See Desk fascia basics page for more details.

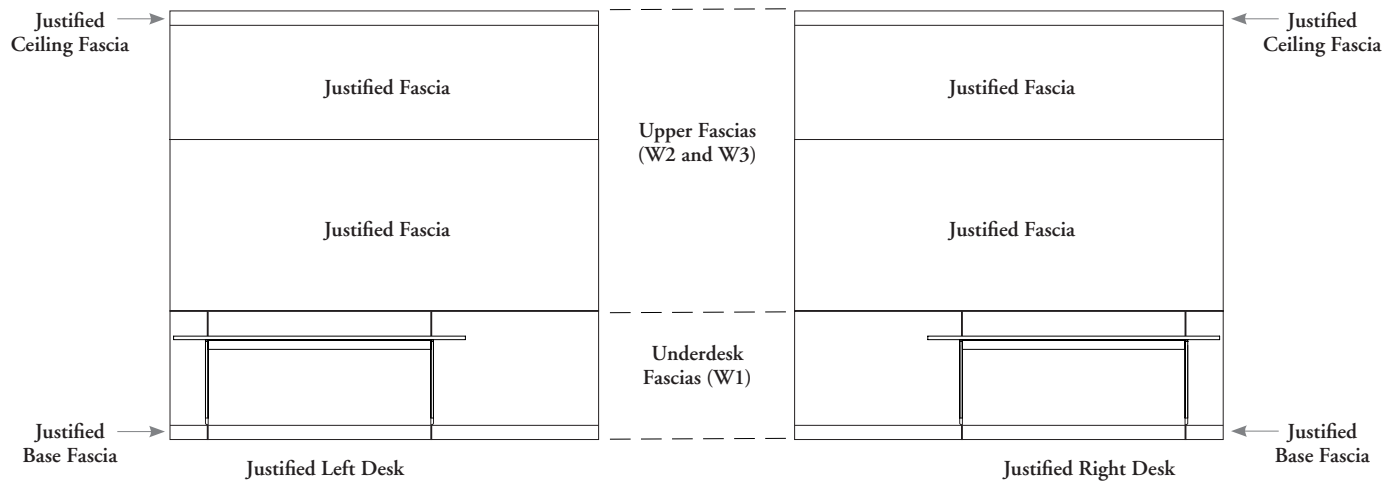

When a desk is centered on the wall module use standard Landscape fascias above the desk, except the ceiling & base fascia which must be justified.

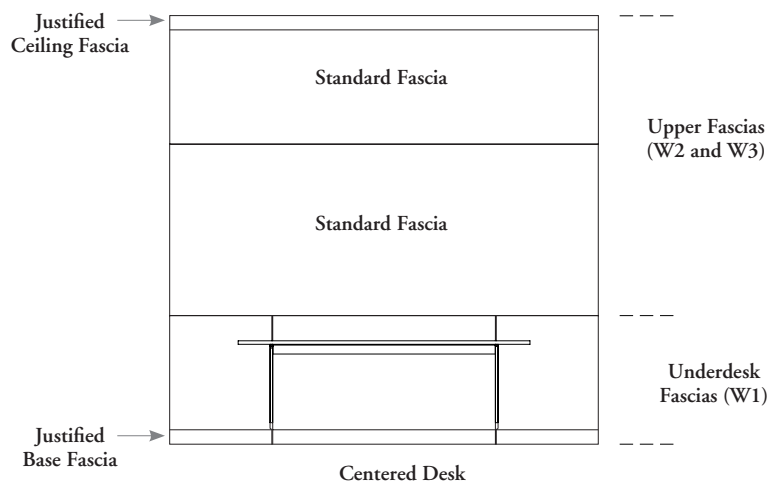

justified fascia elevation basics – landscape

Altos Landscape Justified fascia options include Solid, Glass, Whiteboard, Fabric-Wrapped, Acoustic Tackable Fabric, and Acoustic Metal Micro Perforated. Justified fascias are used with a Desk and can be reconfigured to other justified fascia types after installation without modifying the interior wall structure.

Justified fascias **cannot** be located at W1/WM1 or on Cabinet Working Wall elevations.

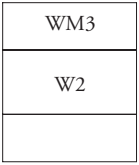
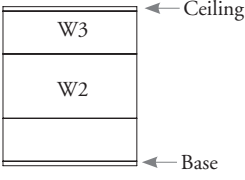
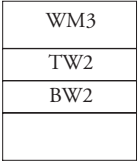
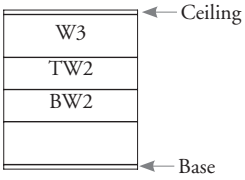
Landscape Arrangement	Fascias Available
<p>Working Wall Monolithic</p> 	<ul style="list-style-type: none"> • WM3 FLJWM3 and FLJRWM3 are 12 - 36" high in 1" increments to accommodate ceiling height • W2 FLJW2, FLJRW2, FLJATW2, FLJMWN and FLJMMF are 48" high
<p>Working Wall Base / Ceiling</p> 	<ul style="list-style-type: none"> • Ceiling: FLJC is 4" high and available in Solid, Fabric Wrapped, Anodized and Painted • W3 FLJW3, FLJRW3, FLJATW3, FLJMPW3 and FLJMBW3 are 12 - 32" high in 1" increments to accommodate ceiling height • W2 FLJW2, FLJRW2, FLJATW2, FLJMWN and FLJMMF are 48" high • Base FLJB is 4" high and available in Solid, Fabric Wrapped, Anodized and Painted
<p>Light Working Wall Monolithic</p> 	<ul style="list-style-type: none"> • WM3 FLJWM3 and FLJRWM3 are 12 - 36" high in 1" increments to accommodate ceiling height • TW2 FLJTW2, FLJRTW2, FLJATTW2, FLJMPTW2 and FLJMBTW2 are 24" high • BW2 FLJBW2, FLJRBW2, FLJATBW2, FLJMPBW2 and FLJMBBW2 are 24" high
<p>Light Working Wall Base / Ceiling</p> 	<ul style="list-style-type: none"> • Ceiling FLJC is 4" high and available in Solid, Fabric Wrapped, Anodized and Painted • W3 FLW3, FLRW3, FLATW3, FLMPW3, FLMBW3, FLGC and FLGD are 12 - 32" high in 1" increments to accommodate ceiling height • TW2 FLJTW2, FLJRTW2, FLJATTW2, FLJMPTW2 and FLJMBTW2 are 24" high • BW2 FLJBW2, FLJRBW2, FLJATBW2, FLJMPBW2 and FLJMBBW2 are 24" high • Base FLJB is 4" high and available in Solid, Fabric Wrapped, Anodized and Painted

desk fascia basics – landscape

Landscape desk fascias accommodate the fixed or height-adjustable desk's connection to the wall frame, and provide access to desk electrics. They work in conjunction with both standard or justified fascias.

- Desk orientation can be Center, Left or Right
- Desk fascias are located on level W1/WM1 only
- Available in Solid
- Not available with Power and Communication cutouts

Landscape Fixed Desk Fascia

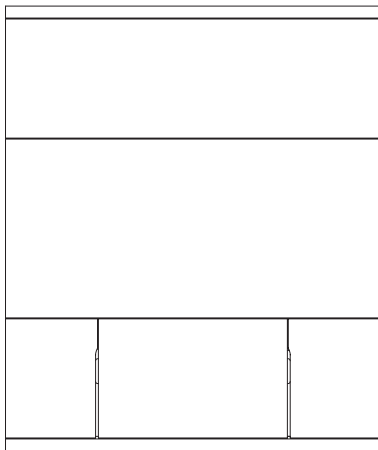

Landscape Fixed Desk Fascias (FLDFW1, FLDFWM1)

- Available for 29" or 42" high Fixed Desks
- Desk Fascia shown combined with Base Fascia

Landscape Height-Adjustable Desk Fascia

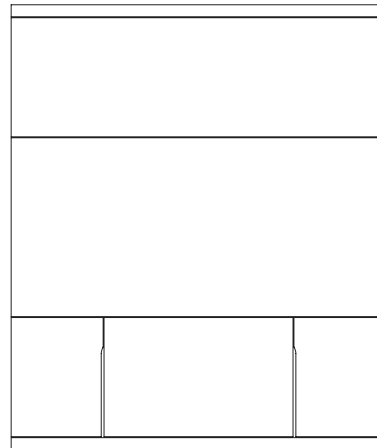

Landscape Height-Adjustable Desk Fascias (FLDHW1, FLDHWM1)

- Accommodates 28" - 44" high Height-Adjustable Desk range
- Desk Fascia shown combined with Base Fascia

fascia finishes – landscape

Solid Fascias

- Available 12" - 120" wide nominal in 1/8" increments
- Available in Fascia Laminates and Flintwood Veneers
- Available on the 4" base and ceiling fascias
- Accepts electrical boxes and switches
- Grain direction is horizontal for Landscape fascias

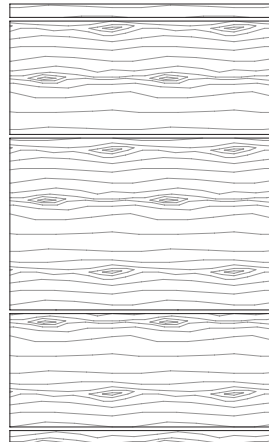

The illustration above demonstrates the grain direction of Cathedral Flintwood finishes for fascias.

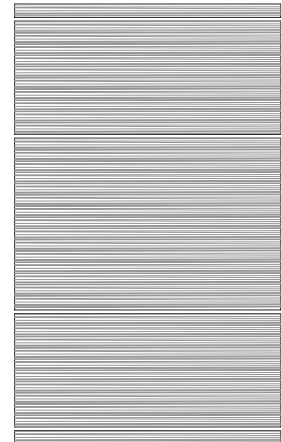

The illustration above demonstrates the grain direction of Standard Flintwood finishes for fascias.

Fabric Wrapped Fascias

- Available in 12" - 120" wide nominal in 1/8" increments
- Fabric Wrapped fascias provide a frameless fabric finish
- Available on the 4" base and ceiling fascias
- Accepts electrical boxes and switches
- Available in select Panel Fabrics
- Upholstery fabrics are not available
- Fabric direction is Railroad for Fabric Wrapped fascias

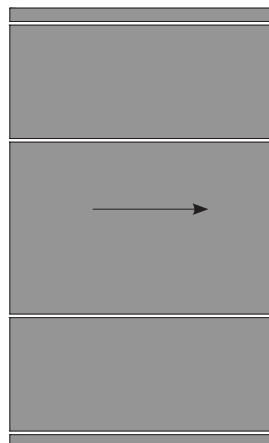

The illustration above demonstrates the Railroad fabric direction for Fabric Wrapped fascias.

Whiteboard Framed Fascias

- Available 12" - 118" wide nominal in 1/8" increments
- Available magnetic or non-magnetic
- Frame finishes include:
 - Clear Anodized
 - Painted
 - Very White
 - Graphite
 - Anthracite
 - Sepia Bronze
 - Burnished Bronze
 - Titanium Grey
 - Gilded Ash
 - Ebony
- Available only in W2 location on Working Wall and Cabinet Working Wall
- Electrical boxes and switches are not available on whiteboard fascias
- Rare-earth magnets of grade N42 are recommended for use on glass whiteboards

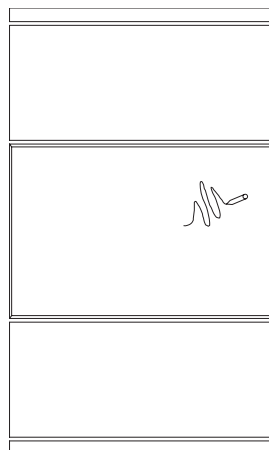

fascia finishes – landscape (continued)

Whiteboard Frameless Fascias

- Available 12" -96" wide in 1/8" increments
- Available magnetic
- Available only in W2 location on Working Wall and Cabinet Working Wall
- Electrical boxes and switches are not available on whiteboard fascias
- Rare-earth magnets of grade N42 are recommended for use on glass whiteboards

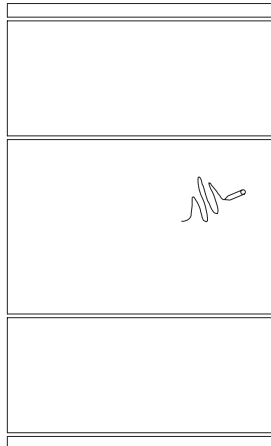

Acoustic Tackable Fascias

- High performance acoustic and tackable fabric fascia used within a space to absorb excess noise
- Available 48" high and 12" – 120" wide nominal in 1/8" increments
- Acoustic Tackable Fascias provide a frameless fabric finish
- Electrical boxes and switches are not available on Acoustic Tackable Fascias
- Available in select Panel Fabrics
- Upholstery fabrics are not available
- Base and Ceiling Fascias are **not** available as Acoustic Tackable Fascias
- Fabric direction is Railroad for Acoustic Tackable fascias

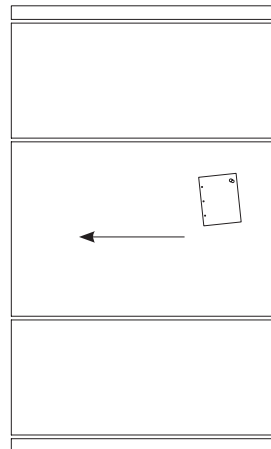

The illustration above demonstrates the Railroad fabric direction for Acoustic Tackable fascias.

Micro Perforated Metal Acoustic Fascias

- High performance acoustic and tackable metal fascia used within a space to absorb excess noise
- Available 12" - 96" wide nominal in 1" increments
- Available magnetic
- Electrical boxes and switches are not available on Micro Perforated fascias
- Acoustic Metal Micro Perforated Fascias that are planned back-to-back must be specified with Landscape Metal Backers (FLMB) to block sound transfer through wall.
- Available in painted finishes:

Foundation:	Mica:
- Crisp Grey	- Platinum
- Soft Gris	- Graphite
- Sand	- Anthracite
- Earth	- Sepia Bronze
- Slate	- Burnished Bronze
- Granite	- Titanium Grey
- Ebony	- Gilded Ash
	- Very White

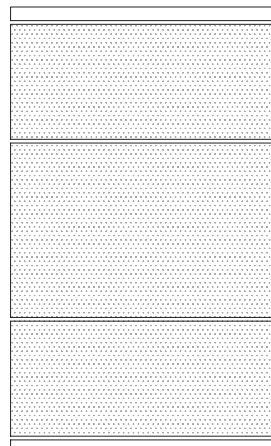

fascia finishes – landscape (continued)

glass fascias

- When clear glass is specified on Double Glass Fascias, both panes will be clear
- When Frosted Glass is specified on Double Glass Fascias only one pane will be frosted; the other pane will be clear
- Single Glass Fascia is centered in frame
- Specialty glass is only available on Glass Fascia – Single Centered
- Available in Clear and Frost

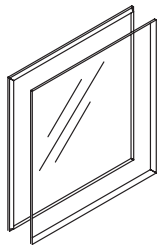

Standard – Clear

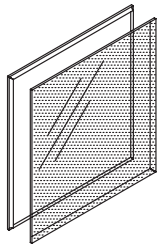

Standard – Frost

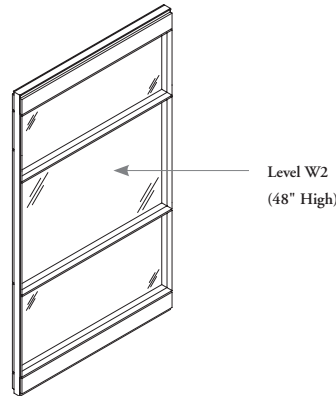

Working Wall Elevation

Glass Fascias

- Available 6mm Single or Double glass
- Landscape Glass fascias are only available in Square Profile.
- Available 12" - 48" high in 1" increments
- Clear tempered or laminated glass finishes available
- Available 12" - 96" wide nominal in 1/8" increments
- Frame Finishes include:
 - Clear Anodized
 - Painted
 - Very White
 - Graphite
 - Anthracite
 - Sepia Bronze
 - Burnished Bronze
 - Titanium Grey
 - Gilded Ash
 - Ebony
- Electrical boxes and switches are not available on glass fascias

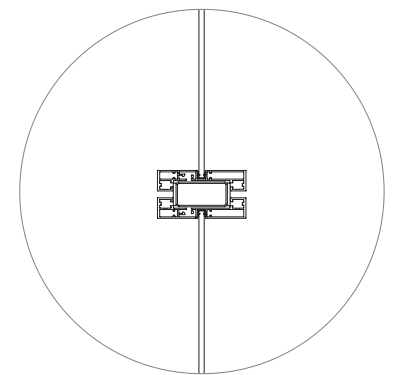
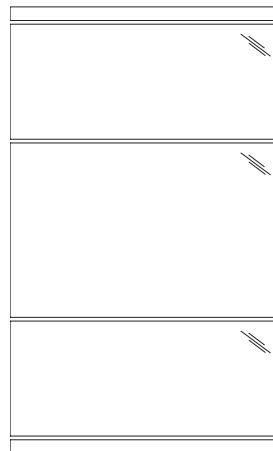

Section of square profile glass fascia

fascia finishes – landscape (continued)

The following finishes are available on Altos Landscape.

aluminum fascias

- Available on the 4" base and ceiling fascias
- Available on most corner, straight and articulating connectors
- Applies to the Landscape Aluminum Fascia Kit (FLFK)
- Coordinates with framed whiteboard and glass fascia frames
- Clear Anodized or Painted options:
 - Ebony
 - Graphite
 - Anthracite
 - Sepia Bronze
 - Burnished Bronze
 - Titanium Grey
 - Gilded Ash
 - Very White

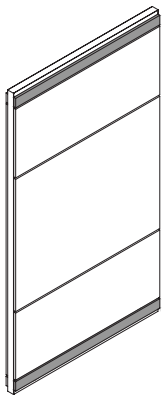

4" Base & Ceiling Fascia

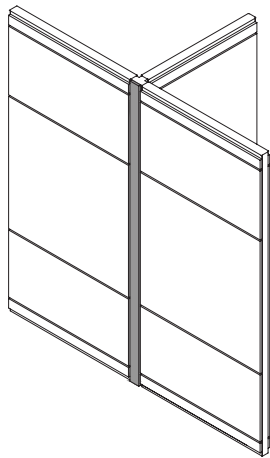

Three-Way 180°

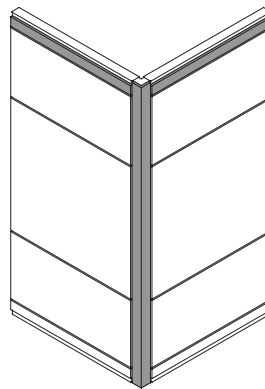

Two-Way 90°

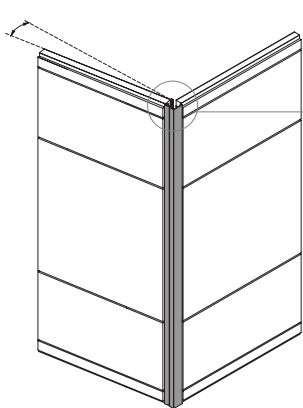

Articulating Corner

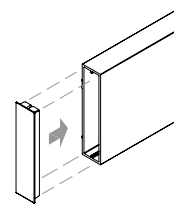
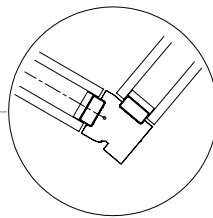

Aluminum

- When specifying an Aluminum Base or Ceiling fascia, the plastic cap will coordinate with the color of the fascia.

fascia finishes – landscape (continued)

grain and fabric directions

Attention must be paid to grain and fabric direction when planning Altos Portrait fascias adjacent to Landscape fascias as the directions will not match. Planning Portrait and Landscape together is possible, however adjacent Portrait and Landscape fascias with fabric or grain direction is not recommended due to directionality mismatch. The Landscape/Portrait Vertical Post (FLKVP) must be specified when transitioning between Landscape and Portrait Frames.

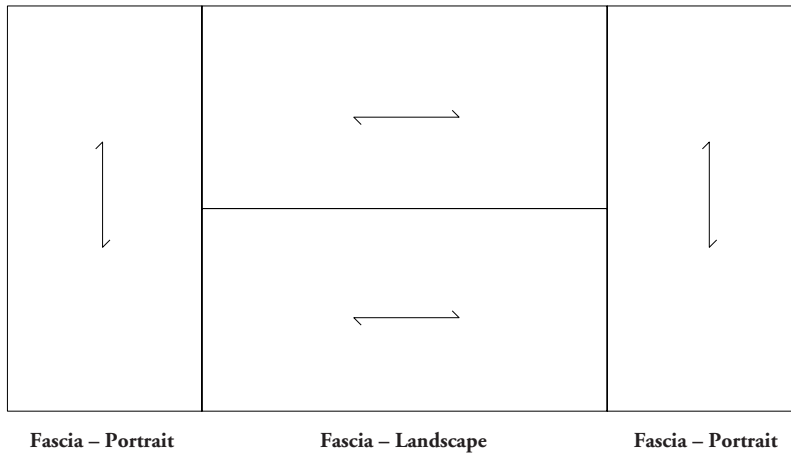

When planning Vertical Trims with Landscape fascias, any grain direction on the Vertical Trim will remain vertical while the grain direction on the fascia will remain horizontal.

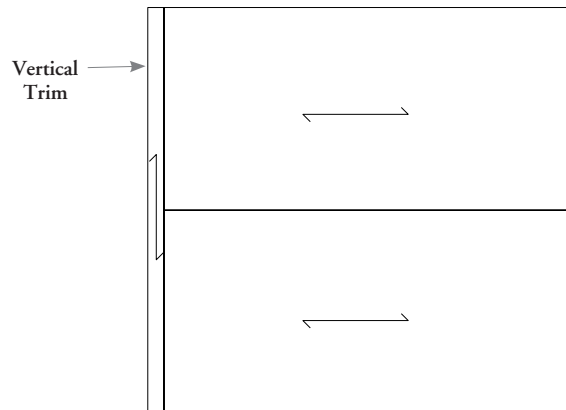

←→ Grain / Fabric Direction

specifying fascia heights – landscape

To determine the correct height for Fascia W3 in the or WM3 in each of the Landscape configurations reference chart below.

4" base and ceiling fascia

	Working (W3)	Working Monolithic (WM3)
Ceiling Height (")	X"	X"
92	n/a	8*
93	n/a	9*
94	n/a	10*
95	n/a	11*
96	8	12
97	9	13
98	10	14
99	11	15
100	12	16
101	13	17
102	14	18
103	15	19
104	16	20
105	17	21
106	18	22
107	19	23
108	20	24
109	21	25
110	22	26
111	23	27
112	24	28
113	25	29
114	26	30
115	27	31
116	28	32
117	29	33
118	30	34
119	31	35
120	32	36

* This size is available for selected finishes. See product pages for size availability.

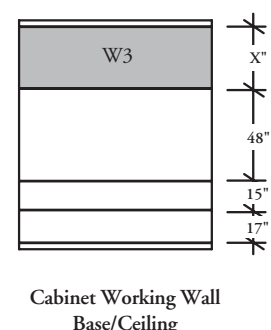
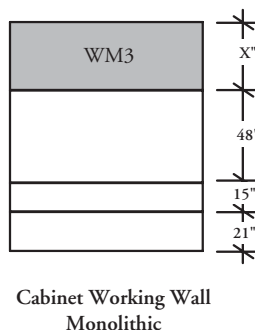
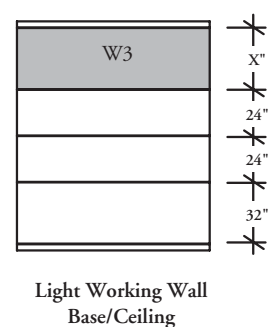
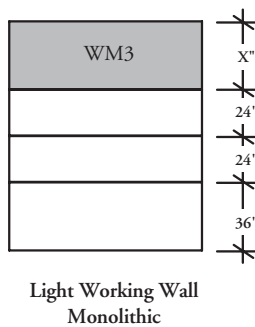
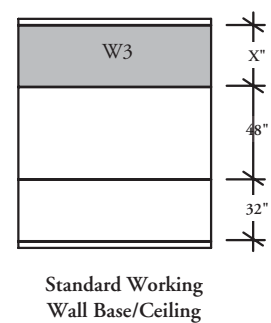
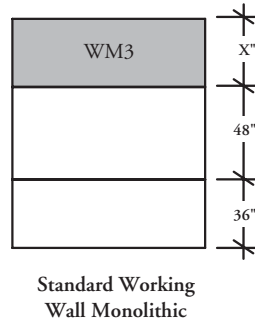

planning with fascias – landscape

Landscape power and communication can be specified at two levels: 15" height or 33" worksurface height.

- Wall modules that require power or communication modules are specified by ordering Fascias with cut out locations
- All cut outs are located right of center-line on the front of the Fascia, this allows for power and communication modules to be specified on both sides of the same wall module
- A Light Switch (ELS) can be installed on Solid or Fabric Wrapped Fascias. For more information on the Light Switch, refer to the guidelines, Lighting, Electrics and Communications section
- Power and communication modules cannot be specified on Acoustic Tackable, Micro Perforated, Whiteboard or Glass Fascias

planning with electrics and communication

15" Height – Vertical Cut Out

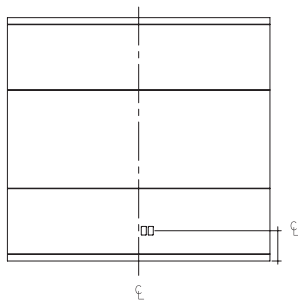

At 15" height, cut outs are oriented vertically for hardwire or power plus communications electrics

15" Above finished floor to center-line of cut out

33" Height – Horizontal Cut Out

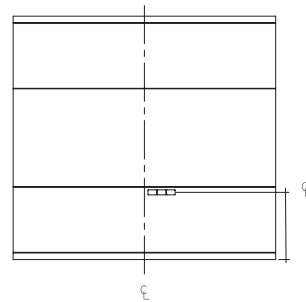

At worksurface height, cut outs are oriented horizontally for hardwire electrics only

33" above finished floor to center-line of cut out

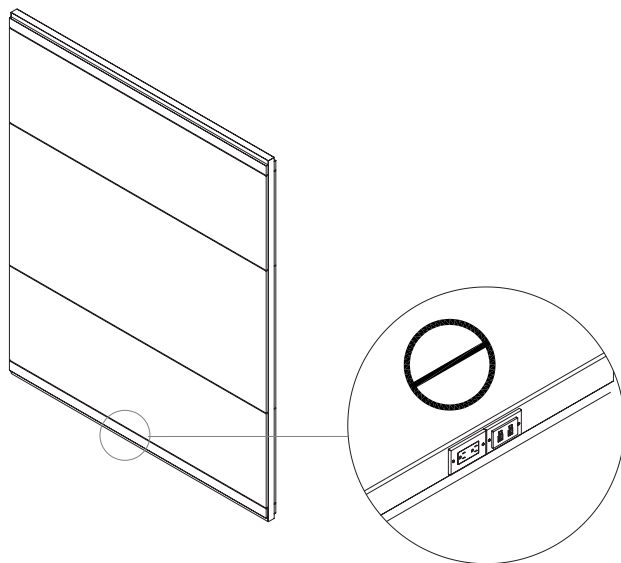

- Power or communication cannot be mounted on the base fascia position with Altos Landscape

planning with fascias – landscape (continued)

Altos Landscape is available with various fascia elevations on either side of the wall.

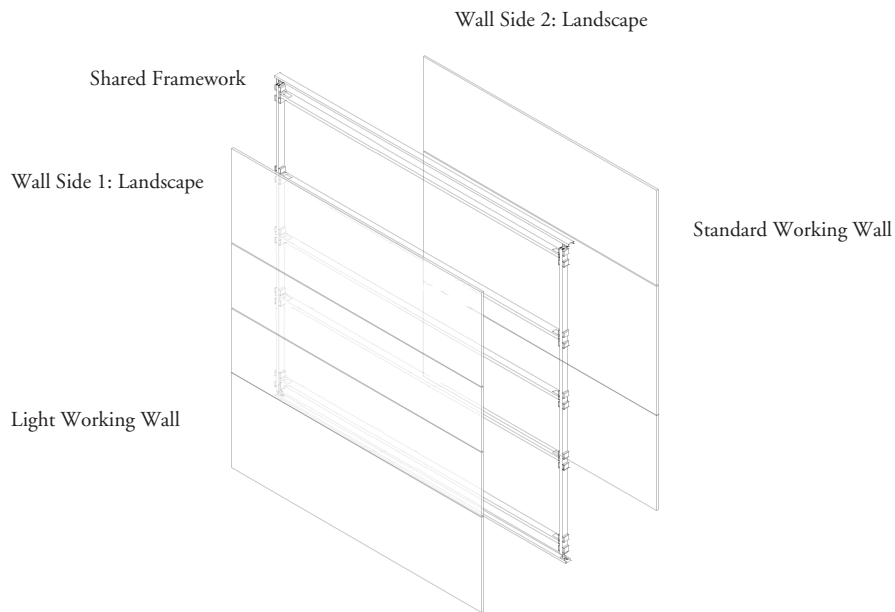

Altos **cannot** be planned with Landscape fascias on one side and Portrait fascias on the other.

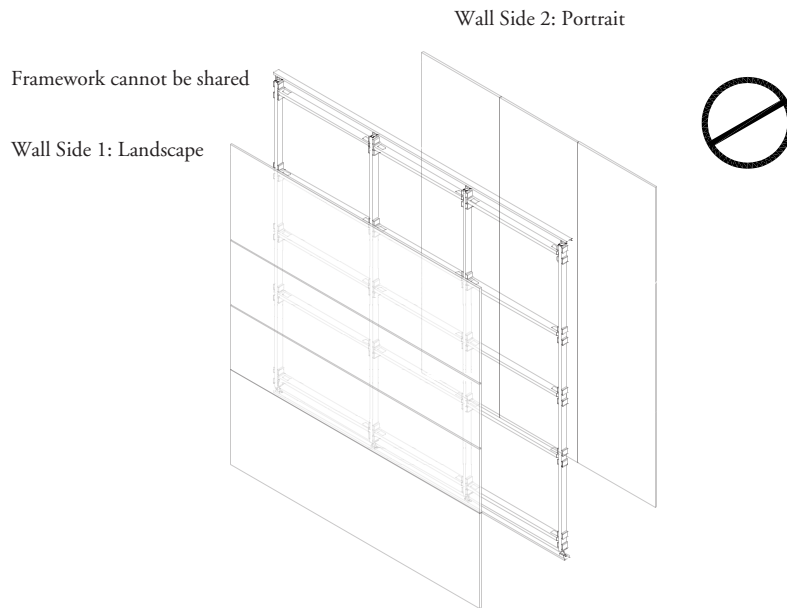

planning with fascia widths – landscape

Landscape fascia widths can be planned strategically to optimize reconfigurability and aesthetic.

Landscape fascias can be planned with consistent fascia widths for future reconfiguration, or with varying fascia widths to maximize horizontal aesthetic.

Consistent Fascia widths

- Planning with the same fascia widths in a kit of parts throughout a floor plate accommodate reconfiguration better than varying fascia widths
- Limiting the number of fascia width variations simplifies reconfiguration and planning

Planning with 1/8" incremental widths

- Landscape fascias can be planned in 1/8" increment widths, extending a fascia up to 120" to the next wall transition
- Planning in this way maximizes Landscape's horizontal aesthetic by eliminating unnecessary verticals, and can result in cost savings

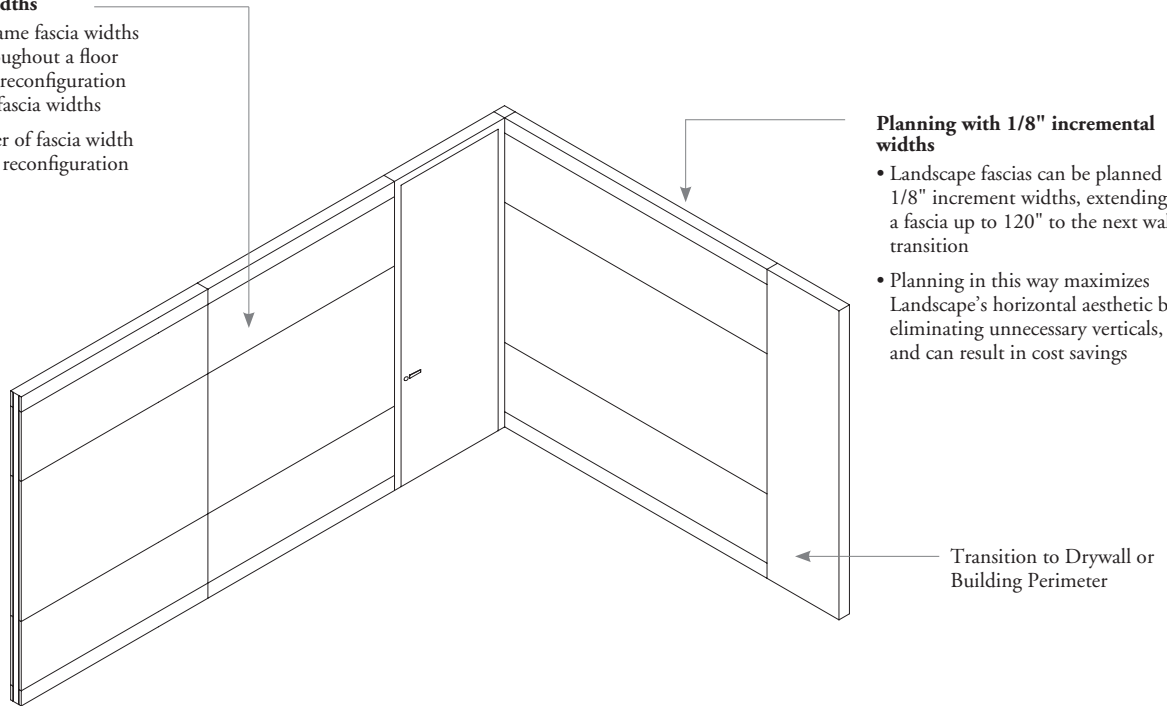

For Landscape wall runs that exceed the maximum width of a fascia, it is recommended to split the wall into two equal fascias to allow for future reconfigurability.

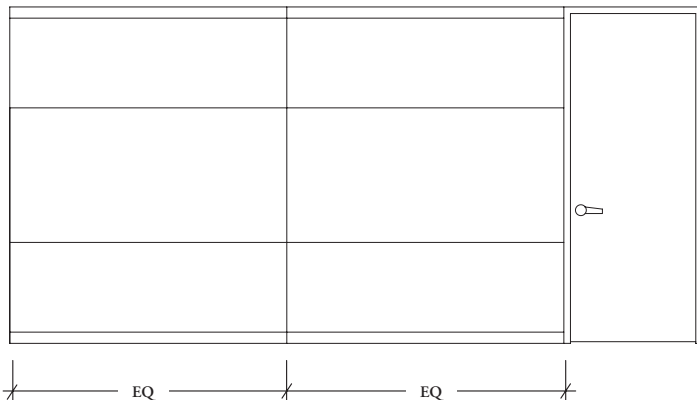

planning with acoustic tackable & fabric wrapped fascias – landscape

Acoustic and Fabric Wrapped Fascias can be used in a variety of applications including training rooms, meeting rooms and private offices.

Acoustic fascias are not available for monolithic MW1 and WM3, use Fabric Wrapped fascias for these applications.

training room

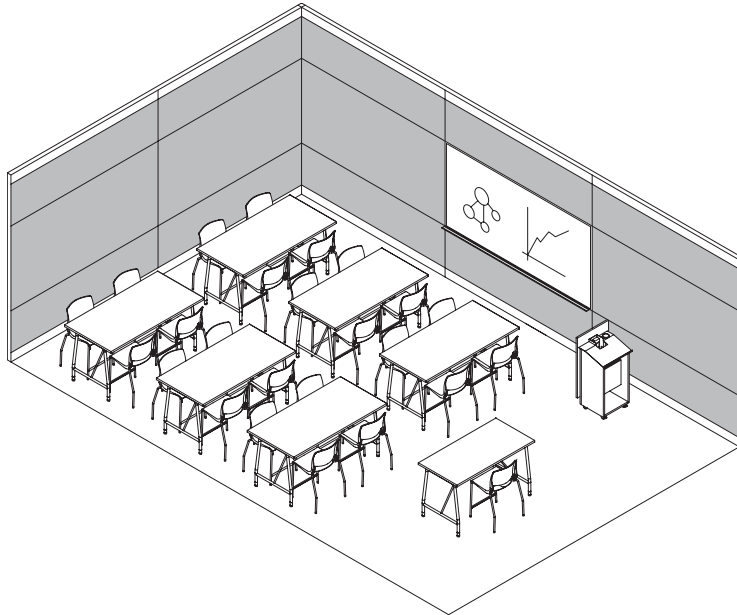

meeting room

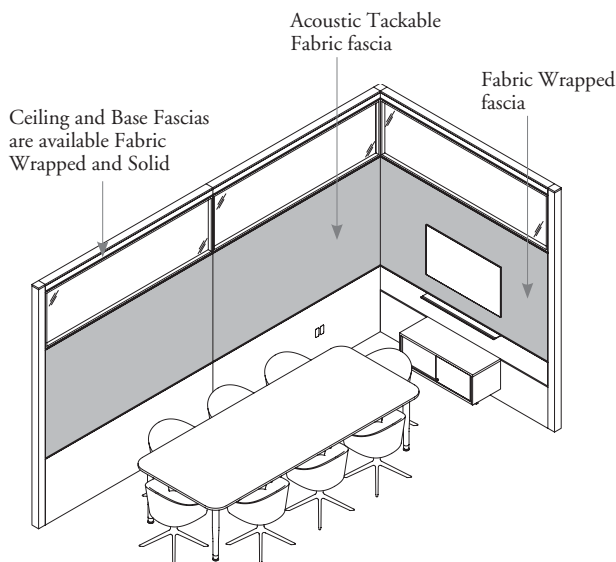

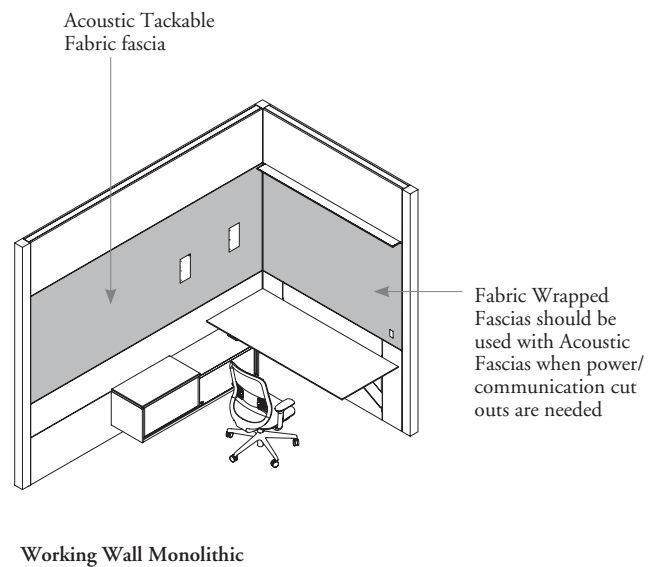

private office







fascia power/communication cut outs – landscape

The number of cut outs for hardwire and power plus communications module electrics depends on Fascia width. The chart below outlines the number of openings available by size in Altos Landscape.

- Power and communication cut outs are available on Landscape Solid and Fabric Wrapped Fascias only
- Fascia Cover Caps (EFCC) can be ordered to cover unused hardwire cut outs

Cut Out Height	Fascia Widths 22" - 31" & 72-1/8" - 90"	31-1/8" - 40" & 90-1/8" -120"	40-1/8" - 72"
Worksurface – Hardwire	 One cut out - FLW1, FLWM1, FLTW1, FLRW1, FLRWM1, FLRTW1 For use with ERM or ECM	 Two cut outs - FLW1, FLWM1, FLTW1, FLRW1, FLRWM1, FLRTW1 For any combination of ERM and ECM	 Three cut outs - FLW1, FLWM1, FLTW1, FLRW1, FLRWM1, FLRTW1 For any combination of ERM and ECM

Cut Out Height	Fascia Widths 12" - 120"	12" - 120"
15" Height – Hardwire	 One cut out - FLW1, FLWM1, FLBW1, FLBWM1, FLRW1, FLRWM1, FLRBW1, FLRBWM1 For use with ERM or ECM	 Two cut outs - FLW1, FLWM1, FLBW1, FLBWM1, FLRW1, FLRWM1, FLRBW1, FLRBWM1 For any combination of ERM and ECM

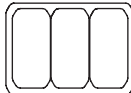
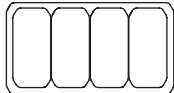
Cut Out Height	Fascia Widths 13" - 120"	17" - 120"	21" - 120"	25" - 120"
15" Height Power Plus Communications Module	 Single (S) – ERGS	 Single (S) – ERGS Double (D) – ERGD	 Single (S) – ERGS Double (D) – ERGD Triple (T) – ERGT	 Single (S) – ERGS Double (D) – ERGD Triple (T) – ERGT Quad (Q) – ERGQ

clerestory basics – landscape

A Landscape clerestory module consists of a Landscape glass fascia above the 84" datum with Landscape fascias below.

- Altos Landscape clerestory is available in the W3 location above the 84" datum
- Available with 4" ceiling fascia in Aluminum, Solid and Fabric Wrapped finishes
- The maximum width for a glass fascia is 96"
- Available with Landscape shelving and light offering: Wall Mounted Light, Aluminum, Whiteboard Tray, Glass and Solid shelves
- Typical Landscape Fascia elevations apply



Restrictions:

- Cannot be used above an Altos Desk
- No ceiling feed path through glass fascia. Ceiling feed must be routed to the side of the fascia or to the floor.
- One Clerestory cannot span over both a Landscape fascia module and an Altos/Optos door together.

planning with clerestory – landscape

The following should be considered when planning with Landscape Clerestory.

When planning Landscape Clerestory in proximity to a door, the vertical trim must continue through the Clerestory for stability. The maximum adjacent wall span cannot exceed 96".

hinged/pivot doors

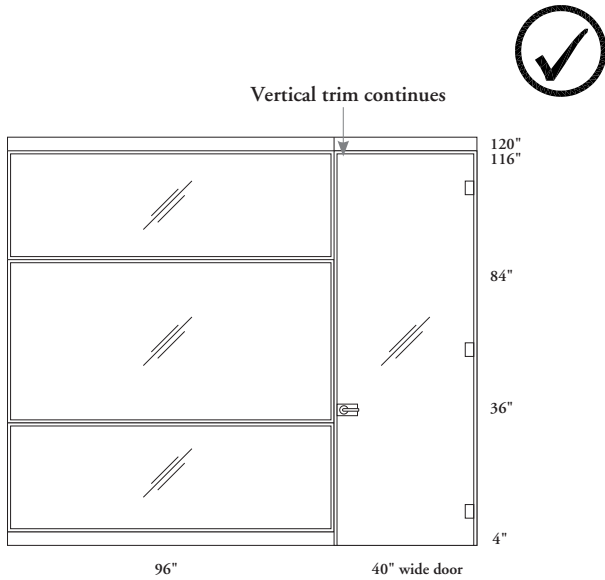

Full height Hinged/Pivot Door
Maximum Glass fascia span of 96"
Possible - Full Height Door

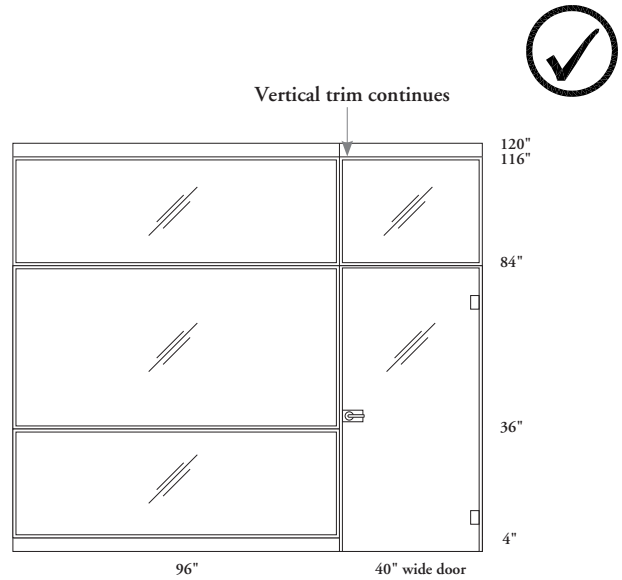

Hinged/Pivot Door under Clerestory
Maximum Glass fascia span of 96"
Possible - Segmented Height Door

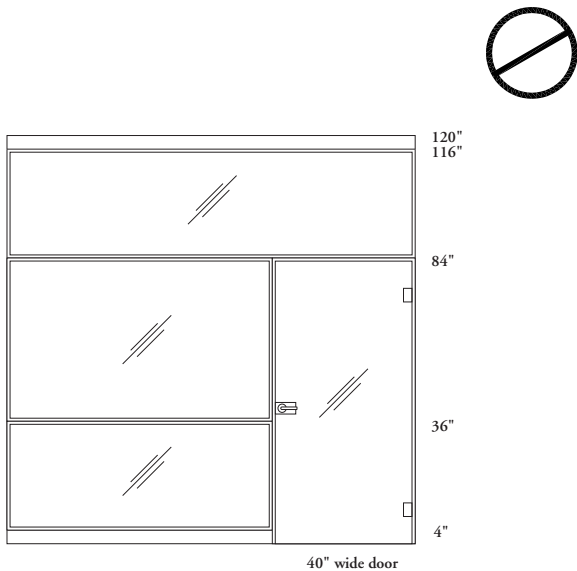

Hinged/Pivot Door under spanning Clerestory
A Landscape glass fascia cannot span over an Altos wall module and a Door.

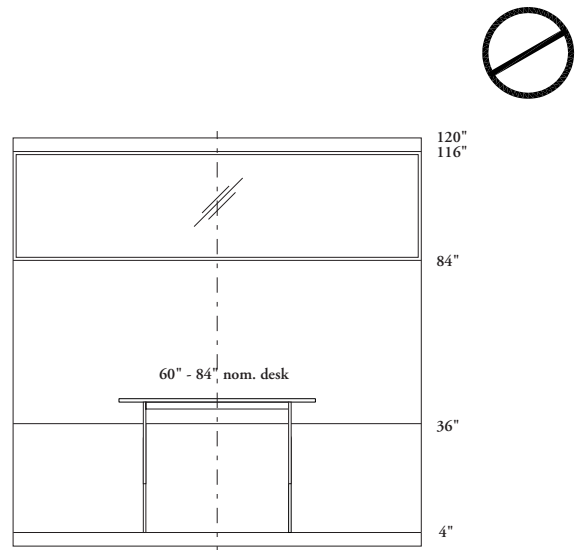

Landscape Desk under Clerestory
Glass fascias cannot be planned above a Landscape Desk

planning with clerestory – landscape (continued)

barn doors

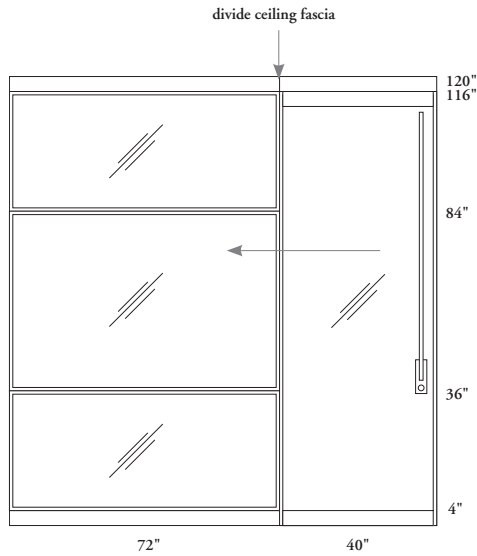

Full height Barn Door

Maximum fascia span of 72" beside Barn Doors

Possible - Full height door

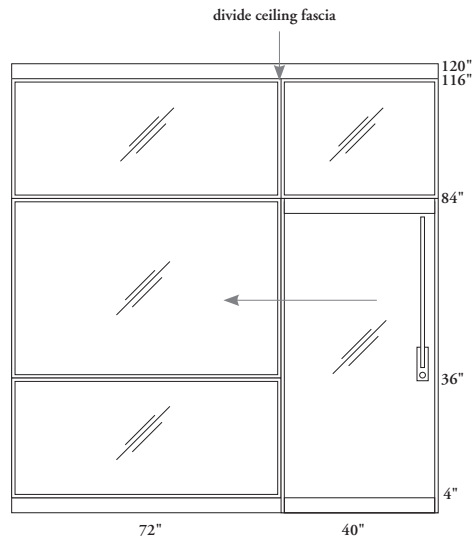

Barn Door under Clerestory

Maximum fascia span of 72" beside Barn Doors

Possible - Segmented height door

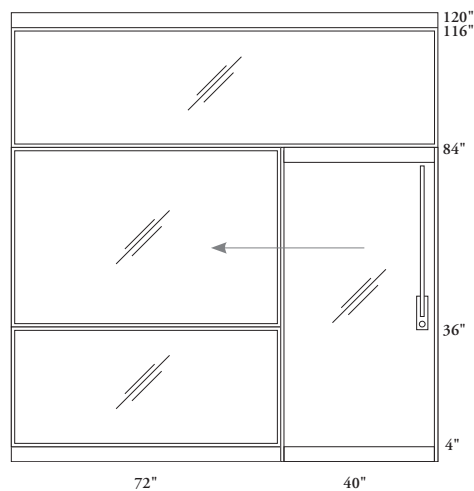

Barn Door under spanning Clerestory

A Landscape glass fascia cannot span over an Altos wall module and a Door

filler panel basics – landscape

The Filler Panel (FPF) is used when an Altos wall surface needs to be cut away to fit the wall around the building structure, usually at the perimeter of the building.

The Filler Panel can be used next to both Altos Portrait or Landscape fascias. Directional finishes for the Filler Panel are vertical, therefore when planning beside Altos Landscape, a non-directional finish is recommended.

Height	Ceiling Height Range
102" (8'-6")	86" to 102" (7'-2" to 8'-6")
108" (9'-0")	103" to 108" (8'-7" to 9'-0")
114" (9'-6")	109" to 114" (9'-1" to 9'-6")
120" (10'-0")	115" to 120" (9'-7" to 10'-0")

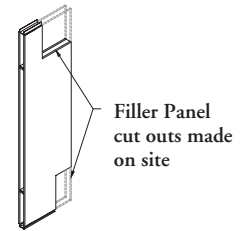
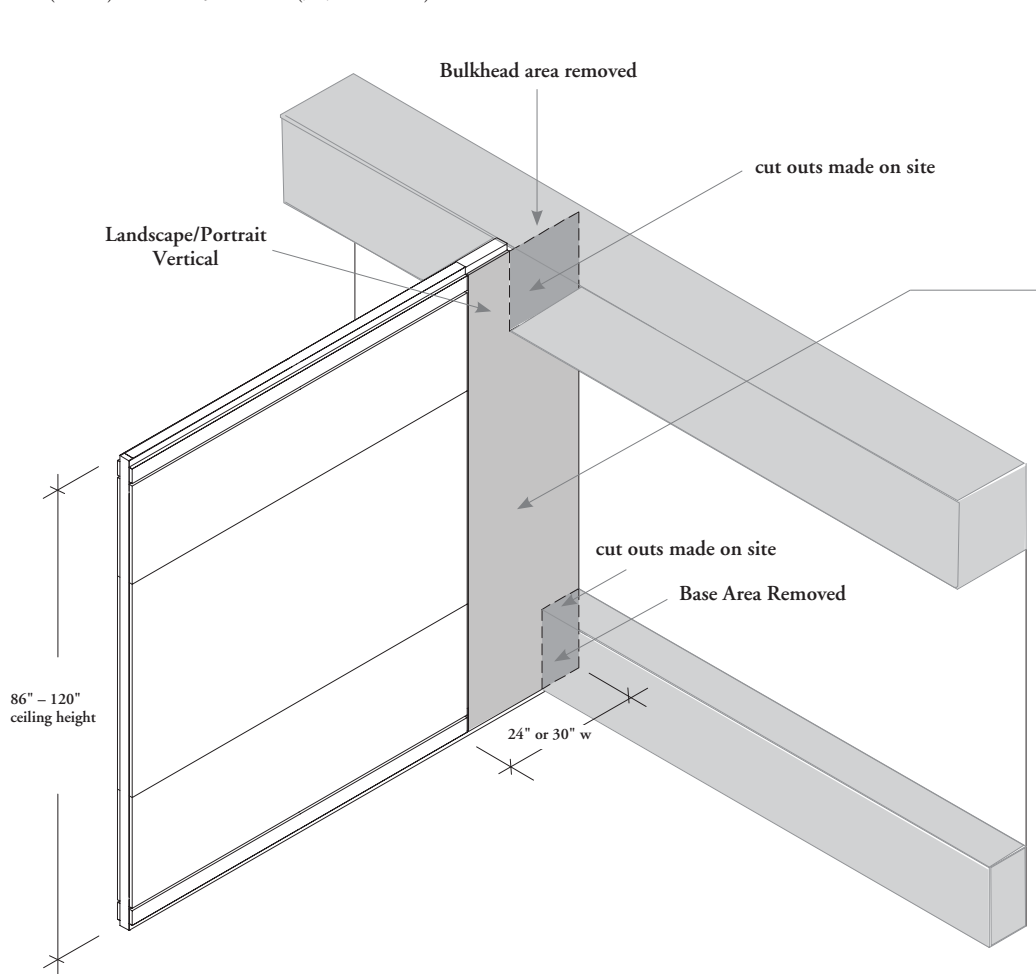

Filler Panel (FPF)

- One floor to ceiling Fascia, no Ceiling or Base Fascias required
- Available in solid finish only with no horizontal reveals
- Can be cut away to a maximum of 6" from floor to ceiling. Amounts greater than 6" can be cut away above and below the horizontal rails
- **Cannot** be used against window mullions
- Has a vertical grain direction for directional finishes

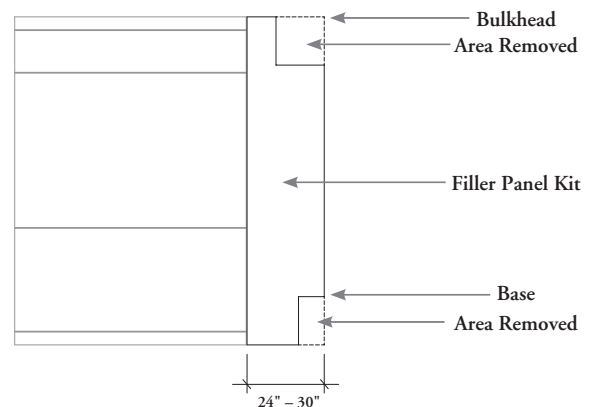

aluminum fascia kit basics – landscape

When electricians must be routed around a Functional Rail or a Glass Fascia, the Landscape Aluminum Fascia Kit (FLFK) can be used to run cables to the floor or ceiling.

The Landscape Aluminum Fascia Kit can be Clear Anodized or Painted in any of the eight Architectural Paints.

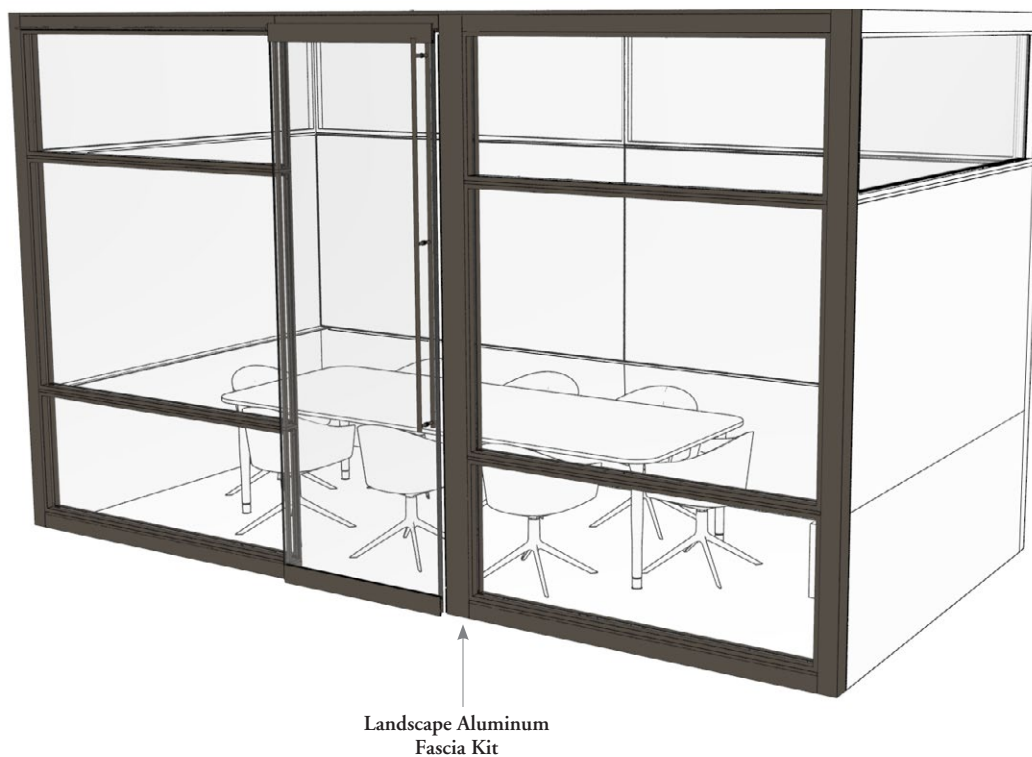

Landscape Aluminum Fascia Kit (FLFK)

- A routing path to the floor or ceiling around Functional Rails or Glass fascias for up to four conduit feeds (3/4" diameter)
- Option for a Wall-Mounted Switch cut out at 42" from the floor
- Option for a Wall-Mounted Electrical Box cut out at 15" from the floor

landscape –
door packages

landscape – door packages

DOOR OVERVIEW – LANDSCAPE	224
HINGED DOOR BASICS – LANDSCAPE	225
PIVOT DOOR BASICS – LANDSCAPE.	226
SINGLE BARN DOOR BASICS – LANDSCAPE	227
DOOR WIDTHS – LANDSCAPE	228
DOOR HARDWARE LOCATIONS – LANDSCAPE	230
TRANSOM HEIGHT – LANDSCAPE	231
BUILDING UP A COMPLETE DOOR MODULE – LANDSCAPE.	232
PLANNING WITH DOORS – LANDSCAPE	233
PLANNING WITH SINGLE BARN DOORS – LANDSCAPE	234

door overview – landscape

For typical openings, Altos Landscape offers a variety of doors that meet a range of privacy and functional needs – the three basic types are: Hinged, Pivot and Barn.

- Solid doors are 1-3/4" thick
- Glass doors are 10mm thick (3/8" nominal thickness)
- Swing doors and frames specified separately
- Barn door jambs and rails specified separately
- Low profile door styles bring the aesthetics of Optos doors into the Altos product line
- Consideration for ADA compliant locking hardware for doors needs to be determined early in the project cycle. Teknion offers a custom special solution that complies with ADA requirements, subject to local approvals.
- Check local regulatory codes for minimum clear height allowed for door openings

building up door modules

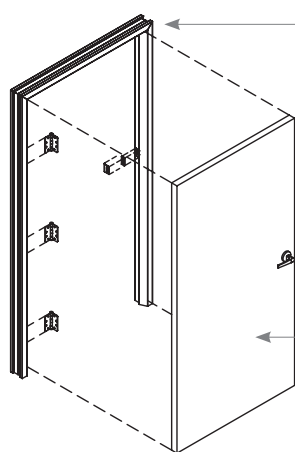

Frame or Transom and Frame Kit
The frame can be customized by height, swing direction, door package type and frame finish

Swing Door
The door can be customized by door type, height, swing/pull direction, lever type, hardware type, drop seal and surface finish

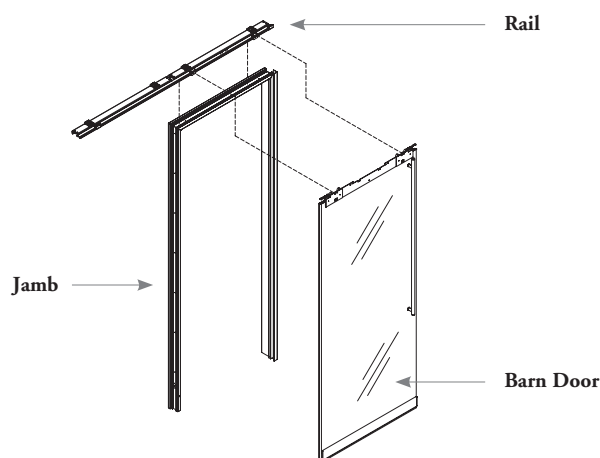

lever types for Swing Doors:

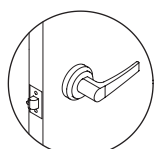

Jupiter

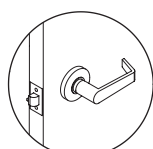

Saturn

handle types for Barn Doors:

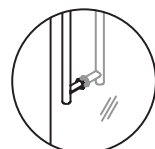

Non-Locking
3/4" diameter
(FDC)



Locking
3/4" diameter
(FDL)

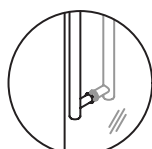

Non-Locking
1" diameter
(FDCZ)

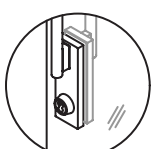

Locking
1" diameter
(FDLZ)

hardware types:

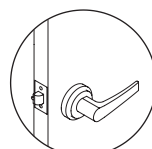

Without Lock
(Passage Set)

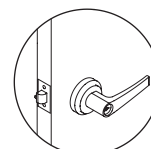

Standard Lock
and Cylinder



Mortise Lock
and Standard
Cylinder

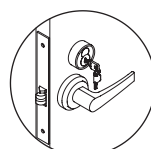

Mortise Lock
and
Interchangeable
Core Cylinder

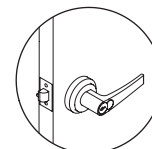

Standard Lock
and
Interchangeable
Core Cylinder

- Doors specified with "Standard Cylinder" are keyed randomly (two keys provided per door)
- Doors specified with "Interchangeable Core Cylinder" are keyed randomly (two keys provided per door) yet can be removed by a universal control key (one key provided per order)
- After installations, customers may choose to relocate or replace interchangeable core cylinders to suit their security needs

hinged door basics – landscape

Hinged doors create an opening with a 180°.

A drop seal is an option to minimize sound leakage at the bottom of the solid doors (up to 0.5" gap under door).

Hinged Door (FDH/FPDH)

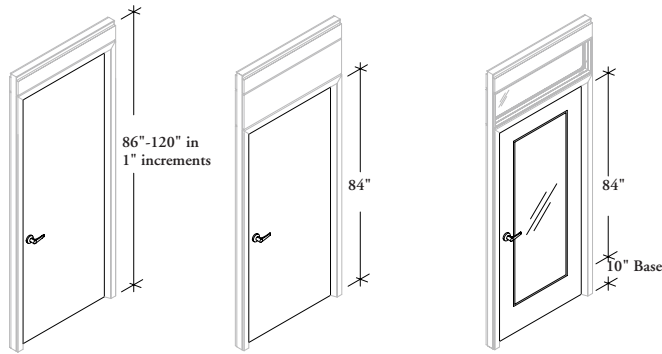

Full-Height

Creates a 180° swing

84" high (with Solid Transom)

- 84" segmented requires a transom measuring between 6" & 30" for ceiling heights between 96" & 120" in 1" increments
- Transom can be Solid or Glass

84" high (with Glass Insert and Glass Transom)

Available with clear or frost glass insert options for privacy aesthetic variation

Hinged Glass Door (FDJ/FPDJ)

An optional 10" high stainless steel kickplate may also be specified

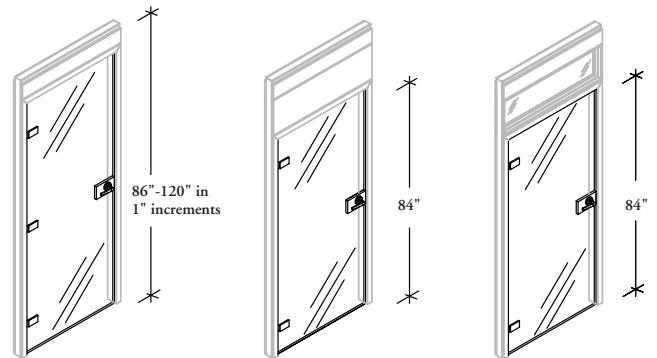

Full-Height

- Door will be ceiling height minus ceiling fascia height
- Transom can be Solid or Glass
- Glass is Clear or Frost and has a 3/8" nominal thickness

84" high (with Solid Transom)

84" high (with glass insert and Glass Transom)

Hinged Double Door (FDD/FPDD)

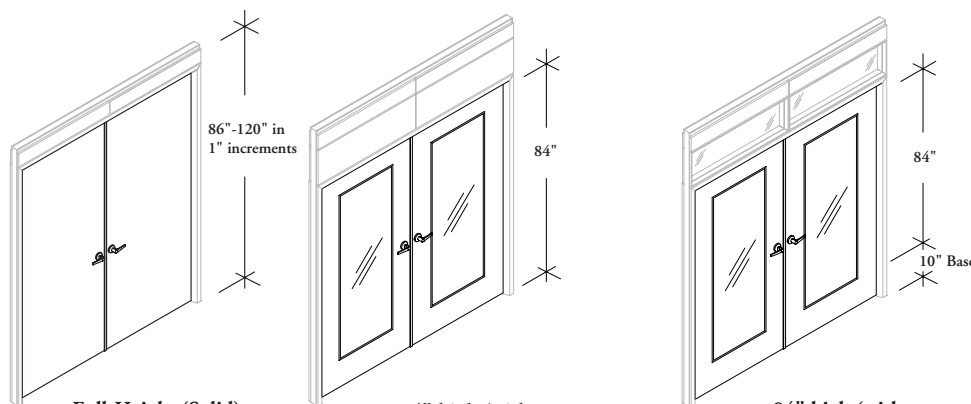

Full-Height (Solid)

84" high (with glass insert and Solid Transom)

84" high (with glass insert and Glass Transom)

- 84" segmented requires a transom measuring between 6" and 32" for ceiling heights between 86" and 120" in 1" increments
- Available with Clear or Frost glass insert options for privacy aesthetic variation – Transom can be Solid or Glass

Hinged Glass Double Door (FDE/FPDE)

An optional 10" high stainless steel kickplate may also be specified

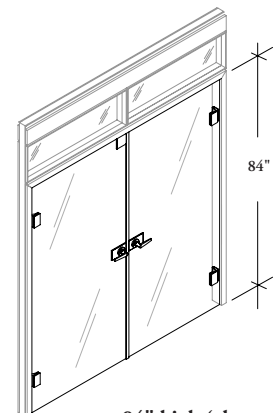

84" high (glass with glass transom)

84" Segmented requires a transom measuring between 6" and 32" ceiling heights between 86" and 120" in 1" increments

pivot door basics – landscape

The Solid Pivot Door uses pivot hardware to attain a 90° swing. The Glass Pivot Door is a full height door that pivots open 180° with an optional adjustable door closer/door stay. It has enhanced acoustic performance offered by its continuous Frame Seal.

Framed Glass Pivot Door (FDPZ/FPDPZ)

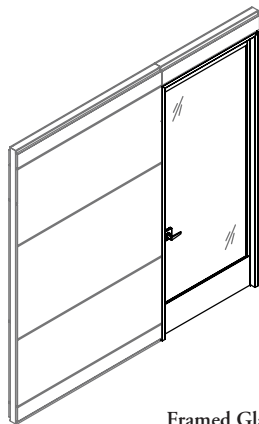

Framed Glass Pivot Door (FDPZ) with a run of Altos

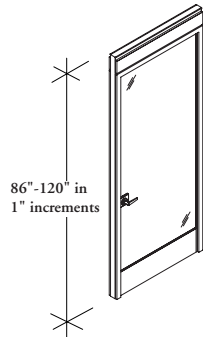

Full-Height
Glass Pivot Door with Fascia

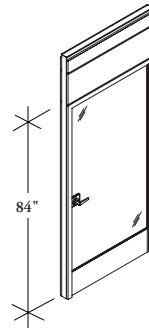

84" high
84" high (with Solid Transom)

- Available with Standard height and 10" high Integrated ADA Aluminum Kickplate
- Available with or without standard lock and interchangeable core cylinder or no lock

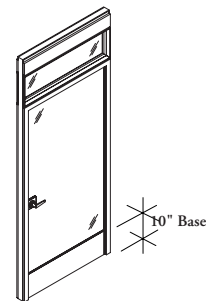

84" high
84" high (with Glass Transom)

- Available with Clear or Frost glass insert options for privacy and aesthetic variation

- Available with 4" or 6" Ceiling Fascia or for Segmented Height with transom
- Glass is available 10mm thick, Tempered or Tempered Laminated
- Two lever types available as standard: Jupiter and Saturn
- Frame finishes include Anodized and Painted finishes

single barn door basics – landscape

The Single Barn Door – Landscape creates a sliding door by mounting to the outside face of wall modules.

- Please check local code requirements, as in some jurisdictions, the use of the Barn Door is limited to room occupancies of 10 people maximum
- Adds 1" to wall module depth
- Locks **cannot** be retrofitted on Barn Doors
- Solid and Solid with Insert **cannot** be used with 4" base and ceiling fascias and therefore **cannot** be used with Landscape fascias
- 48" wide Glass Door is **not** available in ceiling heights greater than 108"
- Consideration for ADA compliant locking hardware for doors needs to be determined early in the project cycle. Teknion offers a custom special solution that complies with ADA requirements, subject to local approvals.

Glass Barn Door (FDC)

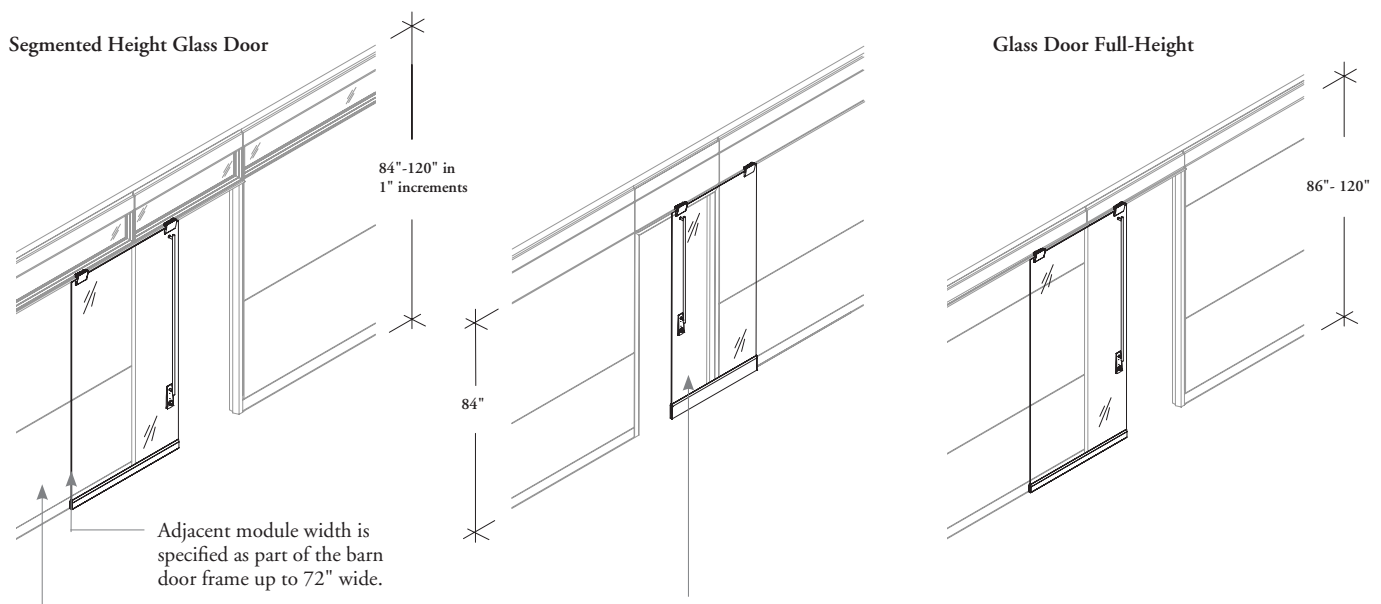

- May be mounted on inside or outside of wall module unless specified with lock, then it must on the outside
- Keyed lock is on the outside and thumb turn on the inside

Slide direction determines left or right handedness (Right-Handed shown)

Glass Barn Door Low Profile (FDCZ)

- Available in widths of 40" and 42" only
- 4" ceiling fascia height
- Door slides can be left or right and can be interior or exterior
- Available with or without standard lock and interchangeable core cylinder
- Glass is available in Tempered and Tempered Laminated
- Can be specified with or without soft close mechanism. Trolley and Base Cover finish include Anodized and Painted
- Should not be used with adjacent Fabric Fascias

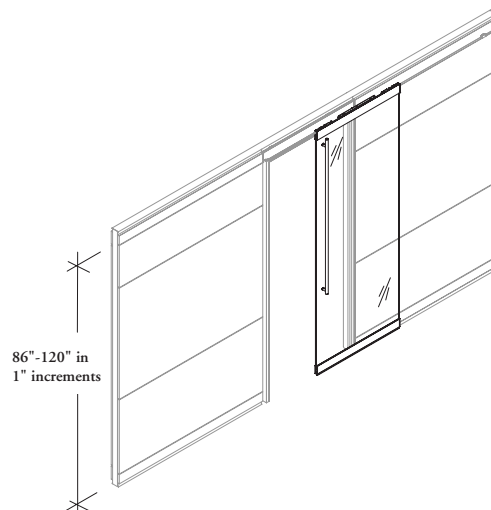

door widths – landscape

Door module (frame and door) widths and door clearances for all doors including frame are shown below.

Single Hinged, Glass and Pivot Doors and Door Frame Package

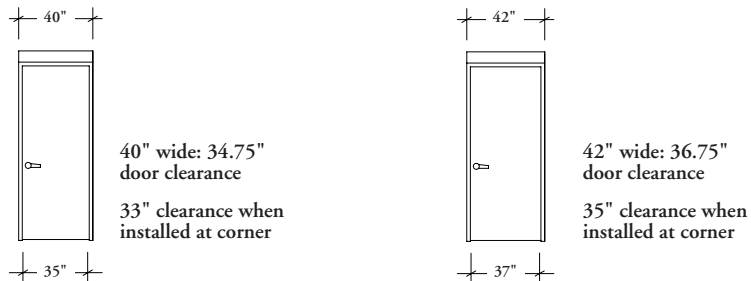

Double Hinged Door and Double Door Transom & Frame Package, Hinged Glass Double Door and Glass Double Door Transom & Frame Package Segmented

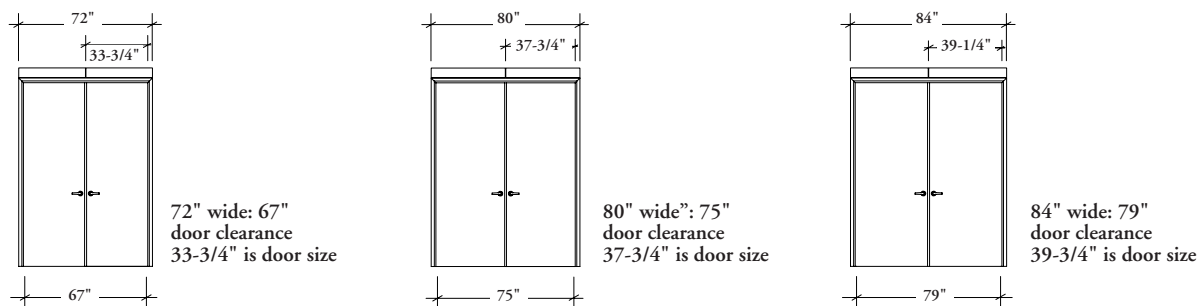

Framed Glass Pivot Door

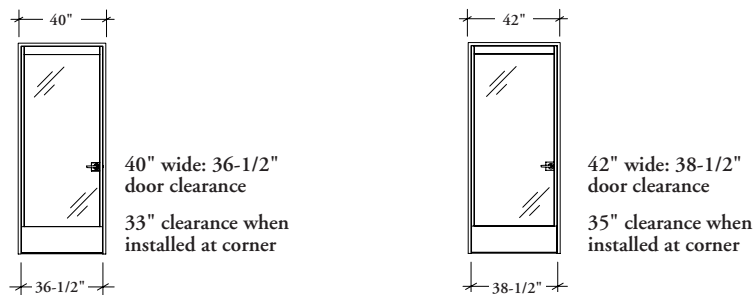

door widths – landscape (continued)

Single Glass Barn Door and Solid Barn Door Transom with Rail and Jamb Package

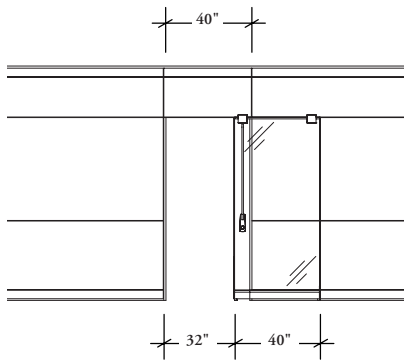

40" wide: 32" door clearance

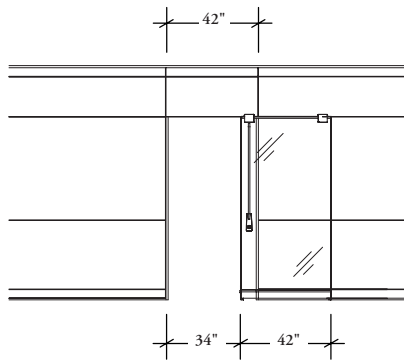

42" wide: 34" door clearance

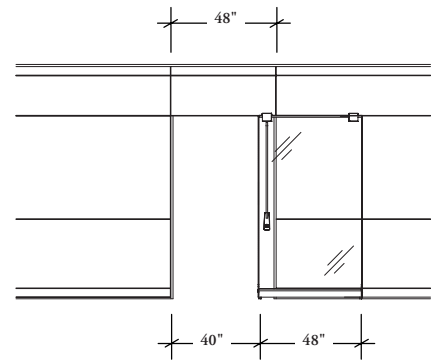

48" wide: 40" door clearance

Single Glass Barn Door Low Profile with Rail and Jamb Package

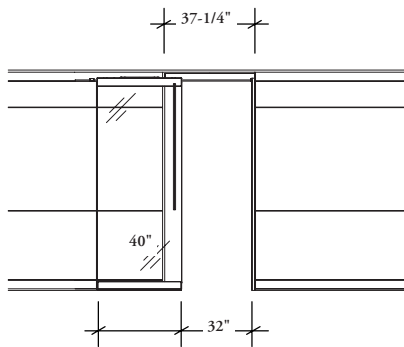

40" wide: 32" door clearance

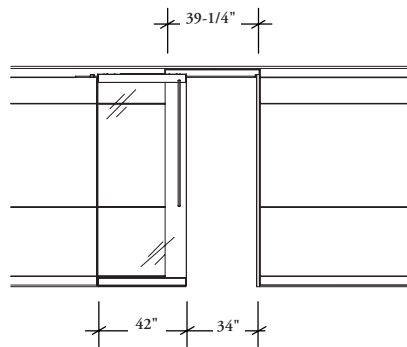

42" wide: 34" door clearance

door hardware locations – landscape

The hardware locations for glass barn door is constant.

AFF Constant

Distant from finished floor to bottom of handle is a constant regardless of the ceiling height.

Type 3 No Lock, Handle AFF constant

Type 4 Standard Lock and IC Cylinder, Handle AFF constant

Ceiling Height	Handle Position AFF
86 - 120	39-3/4

Glass Barn Door Low Profile (FDCZ)

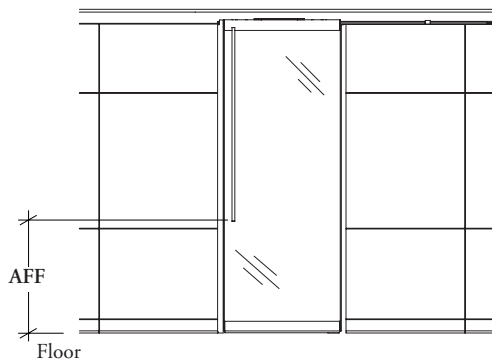

Non Locking

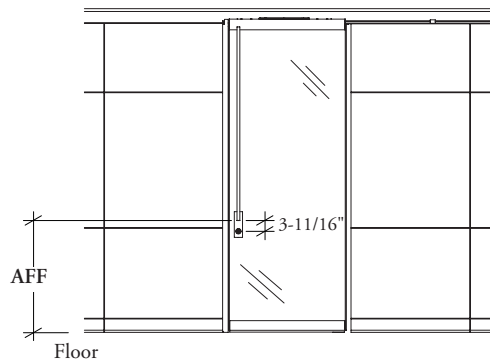

Locking

Nominal AFF is constant for hardware types 3 and 4

transom height – landscape

The height of the transom above 84" high doors varies in relation to the ceiling height.

- To determine the correct height of Fascia for the transom above a 84" high door, use Chart 1: Transom Height
- To determine the correct width of Fascias for the Transom and Ceiling Fascia above the Hinged Double Doors (FDE and FDD) and Barn Doors (FDC) use Chart 2: Double Door/Barn Door Transom Fascia and Ceiling Fascia width chart
- All structural members, Landscape Vertical Post Packages (FLKV), Landscape Horizontal Rail Packages (FLKH), Ceiling Channel (FKN), etc., for doors are specified separately in the appropriate sections. See Frame Kits For more information

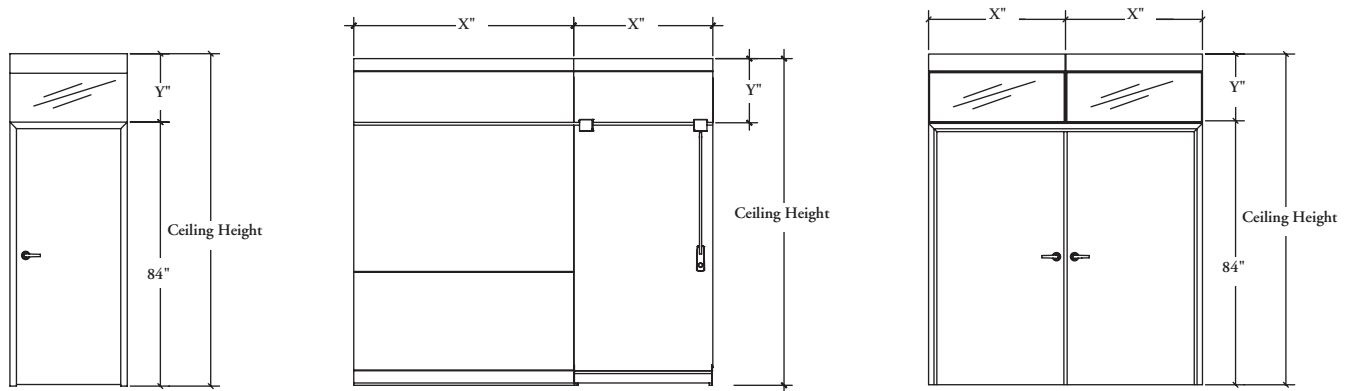

Chart 1:

Transom Height Chart for 4" Ceiling Fascia

Ceiling Height (")	Transom Height Y"
96	8
97	9
98	10
99	11
100	12
101	13
102	14
103	15
104	16
105	17
106	18
107	19
108	20
109	21
110	22
111	23
112	24
113	25
114	26
115	27
116	28
117	29
118	30
119	31
120	32

Chart 2:

Double Door/Barn Door Transom Fascia and Ceiling Fascia Width Chart

Double Door Width (")	Fascia Width X"
72	36
80	40
84	42

building up a complete door module – landscape

Several frame packages are available for door packages. See price pages for details of these products.

- It is not recommended to install a door adjacent to a Wall End (FKE), Wall Start (FKW/FPLW) or Filler Panel (FPF)
- If Fascias are required to complete assembly they must be specified separately

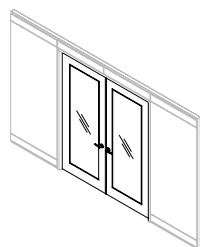

Full Height Hinged Double Door (FDD/FPDD)

- Required Double Door Frame – Full Height (FKTF/FPFDS)
- Used with 4 Ceiling Fascias (FLC) – 2 per side

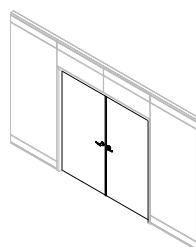

Segmented Double Door (FDD/FPDD)

- Required Double Door Transom & Frame – Segmented Height (FKTS)
- Used with 4 Ceiling Fascias (FLC) – 2 per side
- 4 Solid Fascias – Segmented (FLW3) or 2 Glass Fascia – Double (FLGD) or 2 Glass Fascia – Single Center (FLGC)

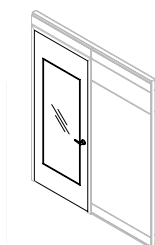

Full Height Hinged Door (FDH/FPDH) or Glass Door (FDJ/FPDJ)

- Required Door Frame Kit (FKD/FPFJS/FPFHS)
- Used with 2 Ceiling Fascias (FLC) – 1 per side



Segmented Hinged Door (FDH/FPDH) or Glass Door (FDJ/FPDJ)

- Required Door Frame Kit (FKD)
- Used with 2 Ceiling Fascias (FLC) – 1 per side
- 2 Solid Fascias – Segmented (FLW3) or 1 Glass Fascia – Double (FLGD) or 1 Glass Fascia – Single Center (FLGC)



Full Height Glass Barn Door (FDC)

- Required for the Portrait Barn Door Rail Kit for Full-Height Door (FLBFR) and Portrait Barn Door Jamb Kit for Full-Height Glass Door (FLBGFJ)
- Used with 2 Ceiling Fascias (FLC) – 1 per side

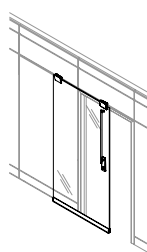

Segmented Glass Barn Door (FDC)

- Required for use with Portrait Barn Door Rail Kit for Segmented-Height Door (FLBSR) and Portrait Barn Door Jamb Kit for Segmented-Height Glass Door (FLBGSJ)
- Used with 2 Ceiling Fascias (FLC) – 1 per side
- 2 Solid Fascias – Segmented (FLW3) or 1 Glass Fascia – Double (FLGD) or 1 Glass Fascia – Single Center (FLGC)

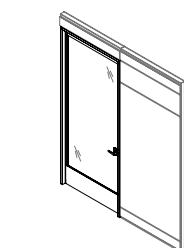

Full Height Framed Glass Pivot Door (FDPZ/FPDPZ)

- Required for use with Glass Pivot Door Solid Frame Kit (FKPSZ/FPFPS)
- Used with 2 Ceiling Fascias (FLC) – 1 per side

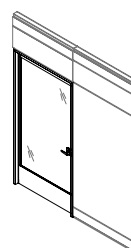

Segmented Framed Glass Pivot Door (FDPZ/FPDPZ)

- Required for use with Glass Pivot Door Solid Frame Kit (FKPSZ)
- Used with 2 Ceiling Fascias (FLC) – 1 per side
- 2 Solid Fascias – Segmented (FLW3) or 1 Glass Fascia – Double (FLGD) or 1 Glass Fascia – Single Center (FLGC)

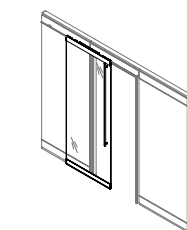

Full Height Glass Barn Door (FDCZ)

- Required for use with Landscape Barn Door Rail Kit for Full Height Door – Low Profile (FLUGFR) and Landscape Barn Door Jamb Kit for Full Height Glass Door – Low Profile (FLUGFJ)
- Used with 2 Ceiling Fascias (FLC) – 1 per side

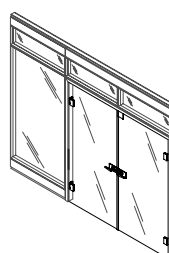

Segmented Hinged Glass Double Door (FDE/FPDE)

- Required for use with Hinged Glass Double Door Transom & Frame Package – Segmented Height (FKTES)
- Used with 2 Ceiling Fascias (FLC) – 1 per side
- 2 Solid Fascias – Segmented (FLW3) or 1 Glass Fascia – Double (FLGD) or 1 Glass Fascia – Single Center (FLGC)

planning with doors – landscape

The following rules should be considered when planning with Altos doors.

- The door swing is identified as right or left according to the location of the hinges
- Door swing orientation must be specified for the Hinged, Hinged Glass, Pivot and Hinged Double door

Pivot and Hinged Door Orientation

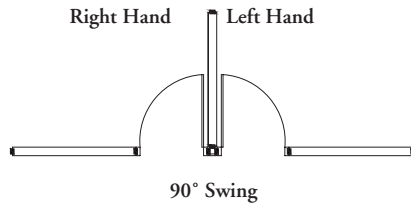

The Hinged Door permits a 180° swing (actual 176° with door stop)

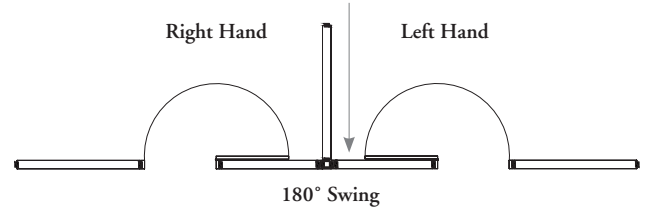

The Pivot and Hinged Glass Doors permit a 90° swing

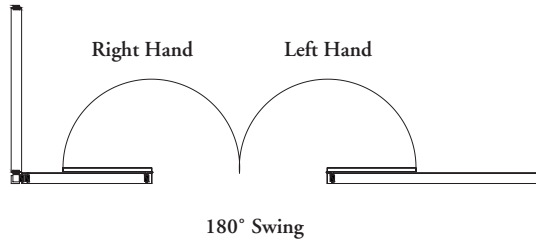

- For the Hinged Double Door, both doors must swing in the same direction
- Door is hinged on frame side only

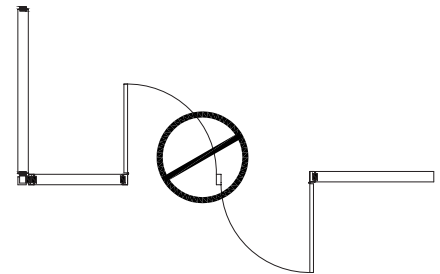

Wall Starts & Filler Panels

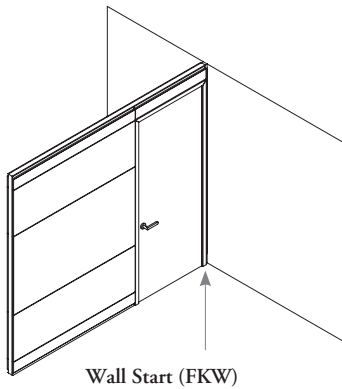

Doors **cannot** be located adjacent to Wall Starts (FKW), Wall starts (FKE), Filler Panels (FPF) or On- Off 3-Way Modules (FKM3) (Wall Start & Filler Panels shown).
Doors can be attached to Adjustable Wall Start (FLKW).

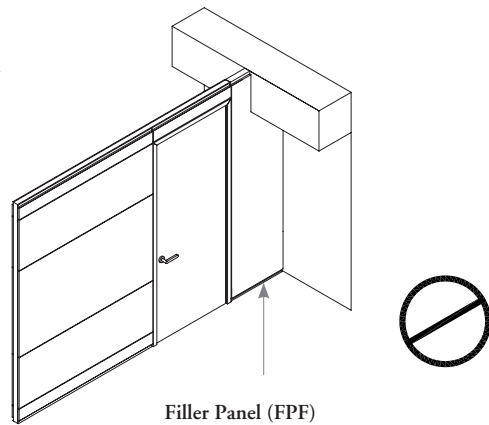

All Doors excluding the 84" high Barn Door may be planned adjacent to any wall type. Corresponding frame kit produces must be specified.

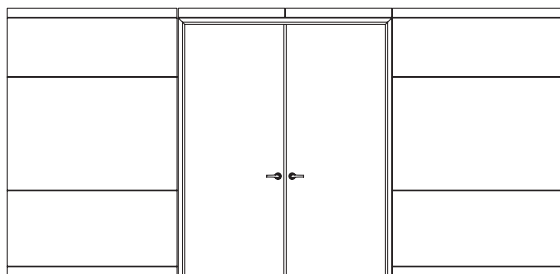

Full-Height Doors

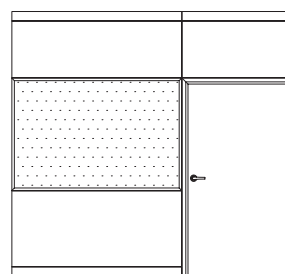

Segmented-Height Door

planning with single barn doors – landscape

The following rules should be considered when planning with Single Barn doors.

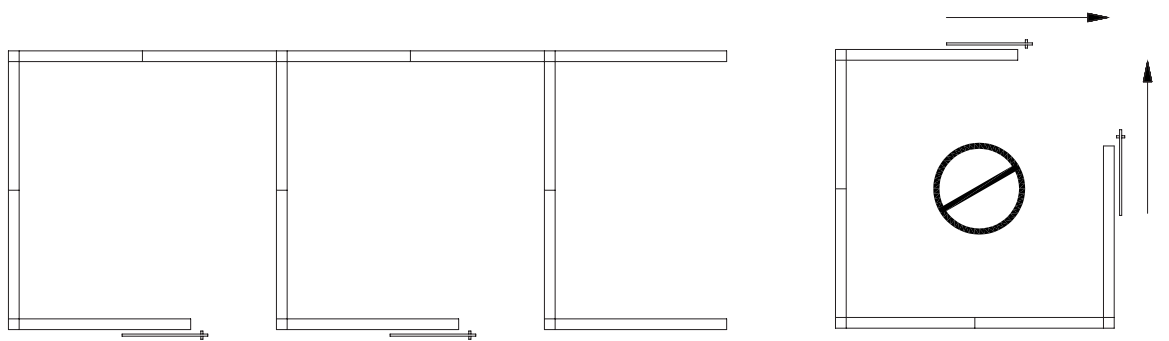
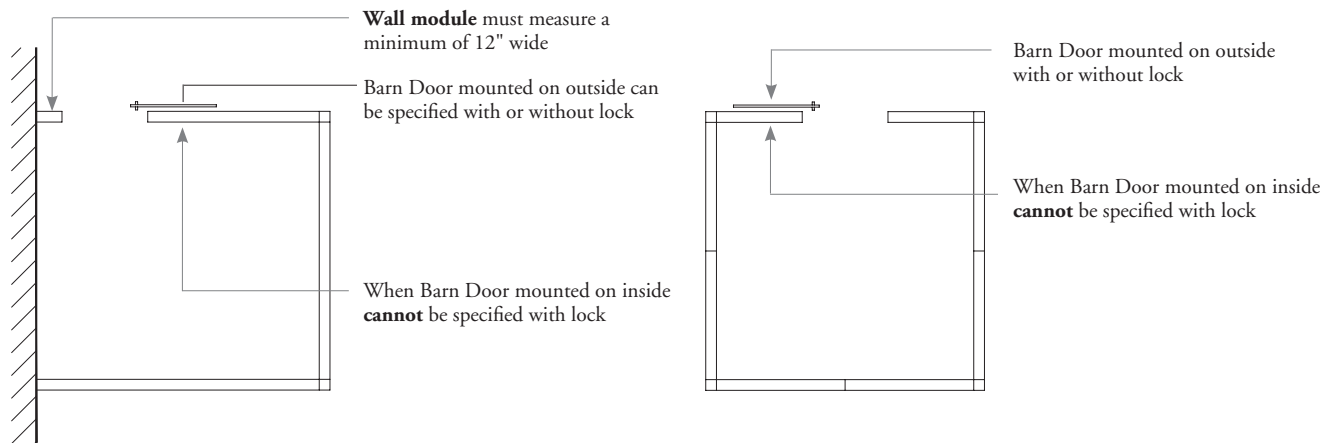

When the Barn Door is located next to a corner connection with an adjoining wall module, the Barn Door **must be** mounted on the outside of a wall run.

Two Barn Doors **cannot** be mounted to meet at a corner.

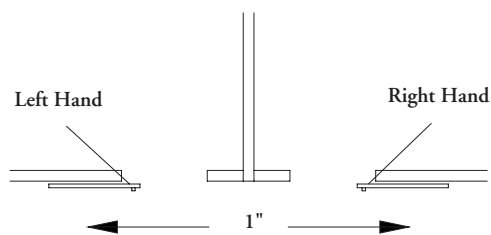

Door slide orientation must be specified for the Single Barn Door (FDC/FDS, FDI). The slide orientation is identified as right- or left-handed according to the direction of travel

When the Barn Door is located next to a corner connection **without** an adjoining wall module, a mechanical fastener securing the corner connection to the floor is required and the Barn Door must be mounted on the outside of the wall run.

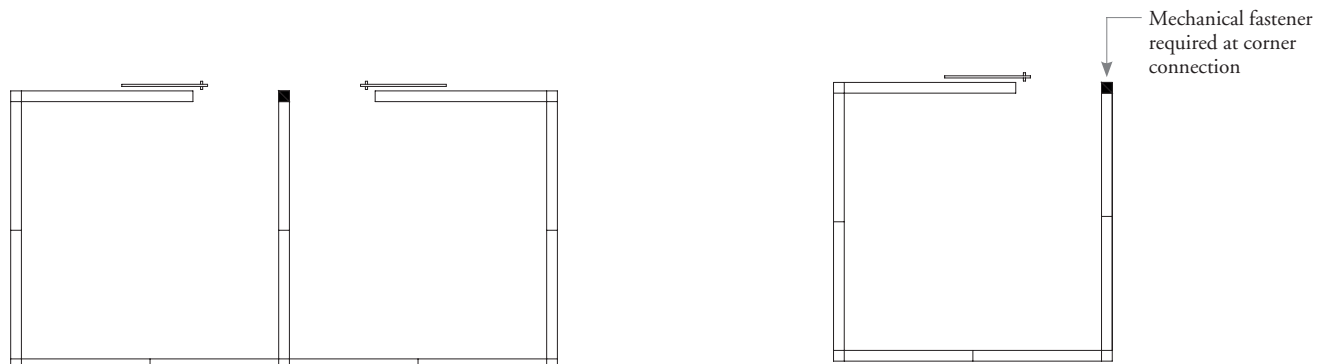

landscape – frame kits &
components

landscape – frame kits & components

FRAME KIT OVERVIEW – LANDSCAPE	238
VERTICAL POST BASICS – LANDSCAPE	239
PLANNING WITH VERTICALS – LANDSCAPE	240
PLANNING WITH VERTICAL POST – LANDSCAPE	241
VERTICAL POST PACKAGE SELECTOR – LANDSCAPE	244
BASE & CEILING CHANNEL OVERVIEW – LANDSCAPE	245
BASE & CEILING CHANNEL BASICS – LANDSCAPE	246
PLANNING WITH CEILING CLIPS – LANDSCAPE	247
PLANNING WITH HORIZONTAL RAILS – LANDSCAPE	248
FUNCTIONAL RAIL KIT BASICS – LANDSCAPE	251
DESK FRAME BASICS – LANDSCAPE	252
WALL GASKET BASICS – LANDSCAPE	253
FASCIA REVEAL INSERTS – LANDSCAPE	254
CORNER & MODULE CONNECTION OVERVIEW – LANDSCAPE	255
90° CORNER CONNECTION BASICS – LANDSCAPE	256
PLANNING WITH 90° CORNER CONNECTIONS – LANDSCAPE	257
135° CORNER COVER BASICS – LANDSCAPE	258
PLANNING WITH 135° CORNER COVERS – LANDSCAPE	259
ARTICULATING CORNER BASICS – LANDSCAPE	260
PLANNING WITH ARTICULATING CORNERS – LANDSCAPE	261
MODULE CONNECTION BASICS – LANDSCAPE	263
PLANNING WITH MODULE CONNECTIONS – LANDSCAPE	264
WALL START & END BASICS – LANDSCAPE	266
FRAME KIT COMPONENT BASICS – LANDSCAPE	267
DOOR FRAME BASICS – LANDSCAPE	268

frame kit overview – landscape

Frame kits are used together to create the structural frame of the Altos wall. Frame kits are specified after the Landscape fascia elevation has been determined.

- Altos Portrait corners and connections are used with Altos Landscape fascias to create In-line, two-way, three-way and four-way transitions
- Any grain or fabric direction for the corner component will have a vertical directionality like Altos Portrait. Solid or Aluminum corner components can be used if matching the directionality of the adjacent Landscape fascia is desired



- 1 Landscape Vertical Post Package (FLKV)
- 2 Landscape Horizontal Rail Package (FLKH)
- 3 Landscape Functional Rail Kit (FLKF)

Not Shown:

Landscape Desk Frame (FLDF)

Wall Start (FKW/FLKW)

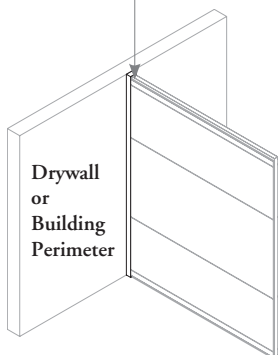

Wall Finished End (FKF)

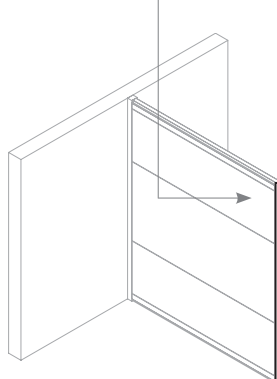

Variable Angle Wall Start (FKWA)

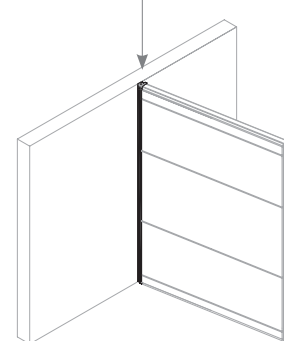

vertical post basics – landscape

The Landscape Vertical Post Package extends from finished floor to finished ceiling and is the vertical support of the Altos frame.

- Landscape Vertical Post Packages (FLKV) are universal when used with Altos Landscape and also fulfill the vertical post requirements for door openings
- Landscape to Portrait Vertical Post Packages (FLKVP) can be used when transitioning between Landscape and Portrait fascias
- The levelers allow for adjustment of +1-1/2 to -0.5" independently at the top and +1-1/2 to -0.5" independently at the bottom

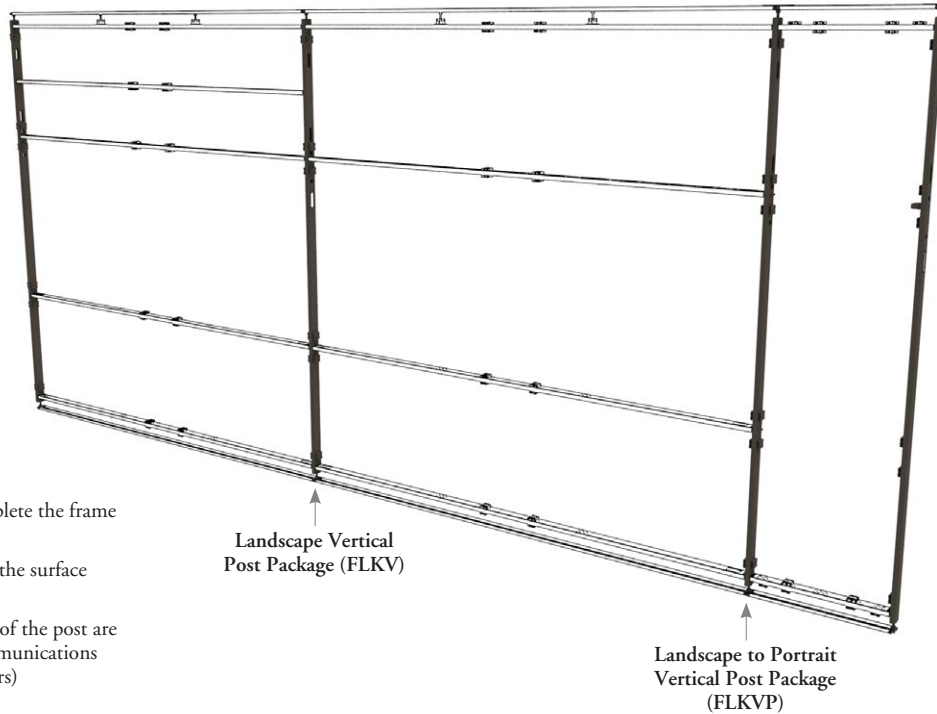

- Accept horizontal rails to complete the frame structure
- Hold Fascias in place to finish the surface and provide space division
- Two cut outs near the bottom of the post are provided for electric and communications pass-through (total of 6 jumpers)

Landscape Vertical Post Package (FLKV)

The Vertical Post Package is made up of the vertical post, levelers and connectors. The connectors can be specified to accommodate all Landscape frame elevations.

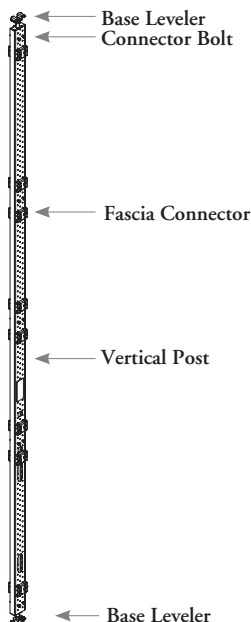

planning with verticals – landscape

The following should be considered when planning with Landscape frame kits.

- Altos uses different vertical packages to transition between different Landscape and Portrait wall types
- When planning with only Portrait fascias, see the Portrait Vertical Post Basics page

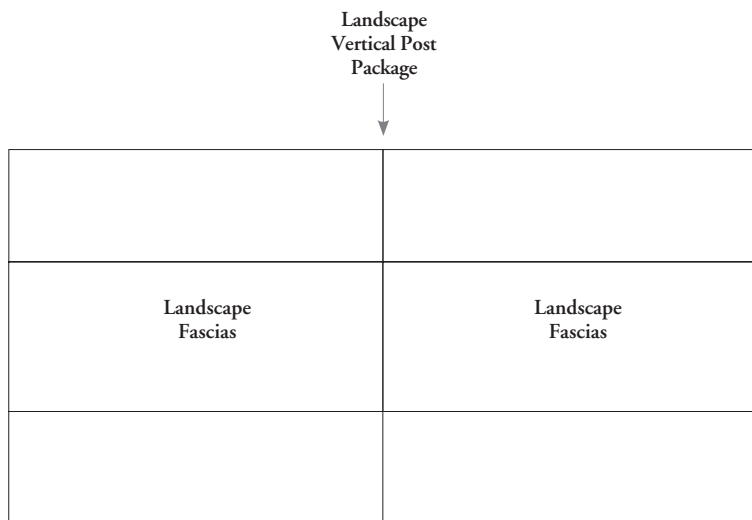

Landscape Vertical Post Package (FLKV)

- Landscape Verticals are used to connect Landscape Fascias to other Landscape Fascias
- Landscape Verticals have large cut outs for Electrical passage at 12" and 30"
- Use the Landscape Vertical Post Package to connect:
 - Landscape Fascias and Horizontal Rail Package (FLKH)
 - Landscape Aluminum Fascia Kit (FLFK)
 - Altos Desk Frame (FLDF)
 - Altos Door Frames
 - Altos Corners and Connections
 - Wall Starts and Wall Ends

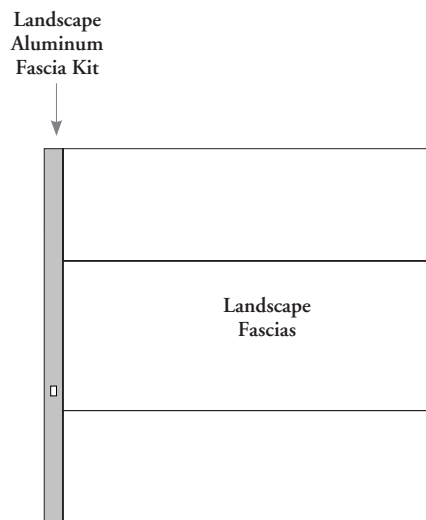

Landscape Aluminum Fascia Kit (FLFK)

- In certain cases where conduit routing is required to the side, the Landscape Aluminum Fascia Kit (FLFK) can be used
- This method can be used to bypass a Functional Rail, which isn't available with electrical passage

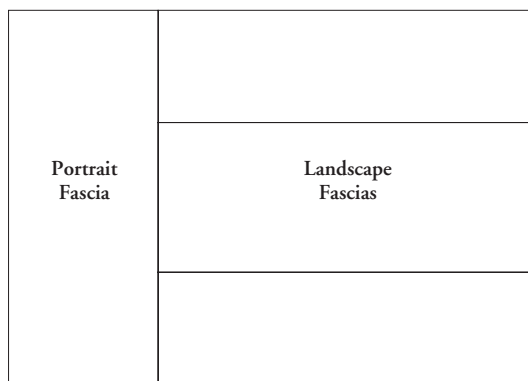

Landscape to Portrait Vertical Post Package (FLKVP)

- Landscape to Portrait Verticals are used to connect Landscape Fascias to Portrait Fascias
- Landscape to Portrait Verticals have large cut outs for Electrical passage at 12" and 30"
- Tek Pier is not available connected to a Landscape elevation

planning with vertical post – landscape

The following should be considered when planning with Landscape Vertical Posts.

There are three steps in specifying Landscape Vertical Post Packages; determining the number and placement of Vertical Post Packages required, selecting appropriate Vertical Post Package type and specifying Landscape Vertical Post Package height.

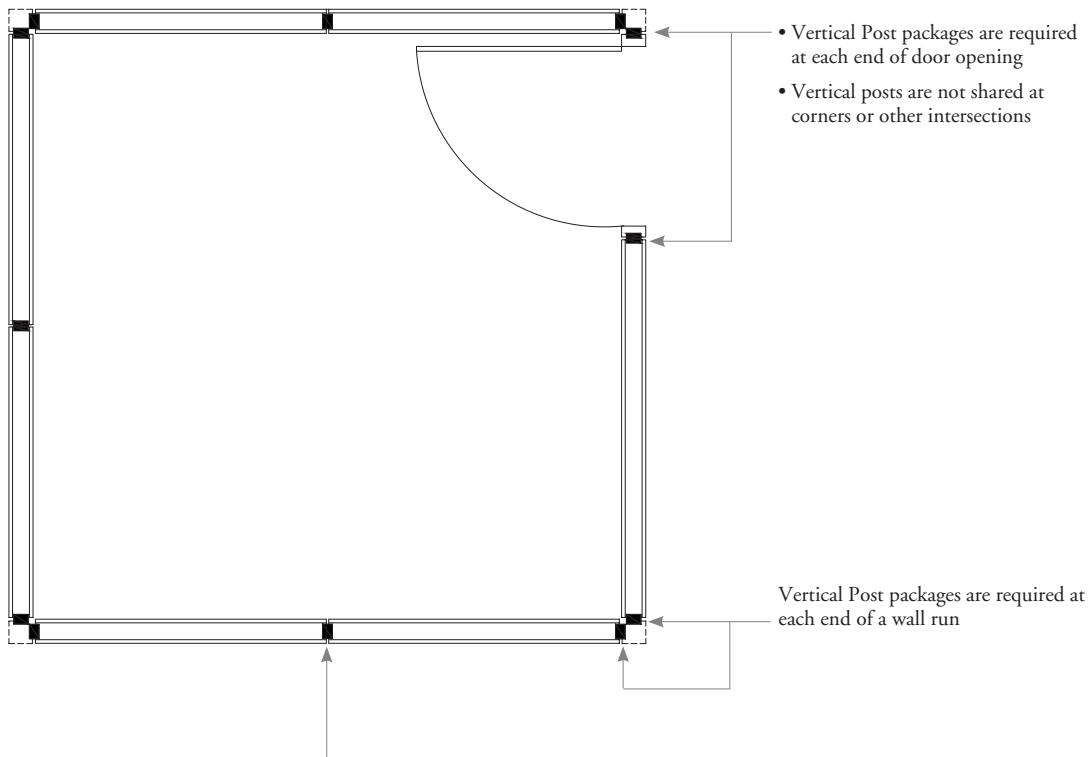

- The starting point for selecting the proper Landscape Vertical Post Package (FLKV) is at the inner and outer elevations of each wall module that will share a Vertical Post Package
- The Landscape elevations that create these elevations determine which type of Vertical Post Package to select
- Always select the post for the highest connector requirements
- When transitioning between Landscape and Portrait, use the Landscape to Portrait Vertical Post Package (FLKVP)

planning with the vertical post – landscape (continued)

selecting a landscape vertical post

The Landscape Vertical Post Package (FLKV) can be used between Landscape fascias, beside Doors, Corners and Connections, Wall Starts, Wall Ends, the Landscape Desk Frame (FLDF) and the Landscape Aluminum Fascia Kit (FLFK). Use the Landscape to Portrait Vertical Post Package (FLKVP) to transition to other Altos Portrait fascias and frames such as the Filler Panel (FPF).

To select the appropriate Landscape Vertical Post Package (FLKV), the fascia elevations surrounding it must be considered.

step 1

Identify up to four fascia elevations surrounding the Vertical Post Package

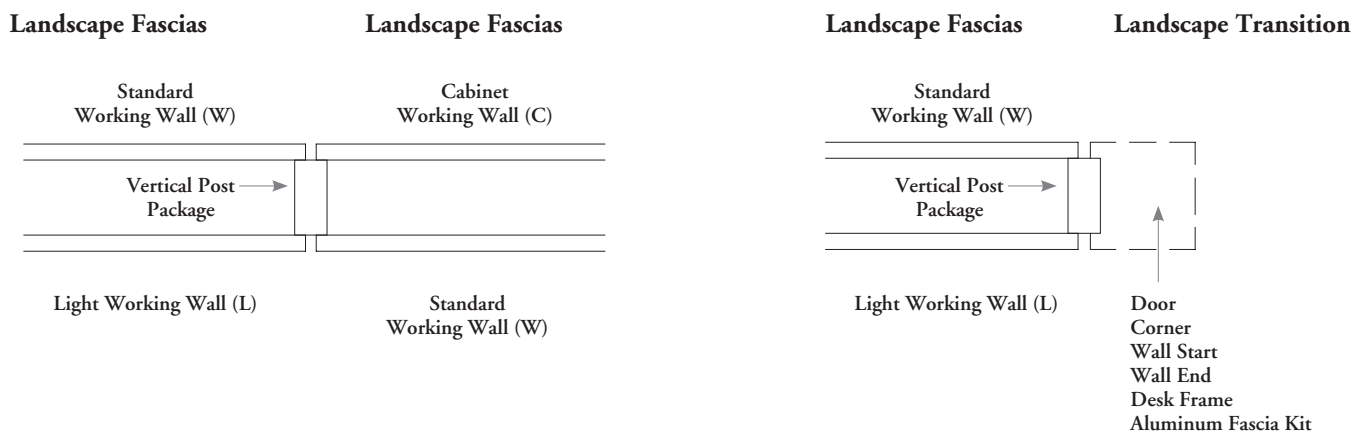

step 2

To determine the elevation type, consult the following Landscape Vertical Post Selection chart:

Fascia Elevation Combinations														
W	W	W	W	C	L	L	L	L	W	W	W	W	W	W
W	W	W	C	C	C	L	L	L	L	W	W	W	L	L
W	W	C	C	C	C	C	L	L	L	L	W	L	L	C
W	C	C	C	C	C	C	C	L	L	L	L	C	C	C
FLKV	FLKV	FLKV	FLKV	FLKV	CR*	CR*	CR*	FLKV	FLKV	FLKV	FLKV	CR*	CR*	CR*
W	C	C	C	C				L	L	L	L			
Vertical Required**														

*For planning applications with a Light Working Wall and a Cabinet Working Wall connected to the Vertical Post Package, a unique Customer Request (CR) is required. See your Teknion Dealer Support for details.

**Some combinations of fascia elevations require extra Horizontal Connector Bolts (FBN) for connection to the Landscape Horizontal Rail Package. These bolts are available from stripped down verticals on site (beside doors, corners, etc). See your Teknion dealer for details.

step 3

Consider both sides of the wall when selecting Functional Rail locations (21", 36", 60" and 84" horizontal datums)

Vertical post packages are available in heights that increase in 1" increments between 86"-120". These heights correspond to the dimension between finished floor to the underside of the finished ceiling.

When accessing pricing for Vertical Post Packages, you will be presented with the following height ranges:

Height Code	Height Range	Height Code	Height Range
102	86"-102"	108	103"-108"
114	109"-114"	120	115"-120"

These height ranges are for pricing only. Be sure to indicate the exact height required for the Vertical Post Package in the product code.

planning with the vertical post – landscape (continued)

selecting a landscape to portrait vertical post

Use the Landscape to Portrait Vertical Post Package (FLKVP) to transition to other Altos Portrait fascias and frames such as the Filler Panel (FPF). A vertical post is not necessary to connect to Tek Pier.

To select the appropriate Landscape to Portrait Vertical Post Package (FLKVP), consider the fascia elevations surrounding it:

step 1

Identify the two Landscape fascia elevations on one side of the Landscape to Portrait Vertical Post Package.

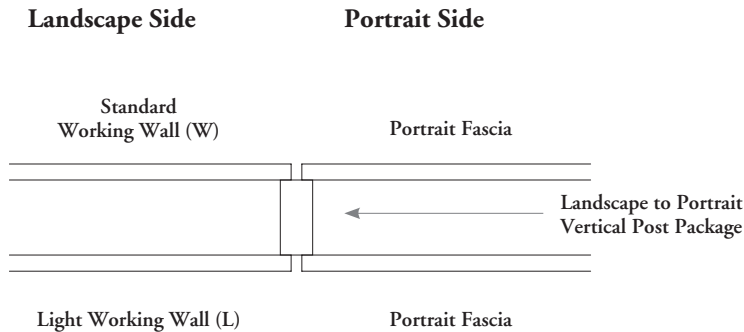

step 2

To determine the Landscape Side elevation type, consult the following Landscape to Portrait Vertical Post Selection chart.

Landscape Elevation Combinations					
W	W	C	L	L	W
W	C	C	C	L	L
FLKV	FLKV	FLKV	CR*	FLKV	FLKV
W	C	C		L	L
Vertical Required**					

*For planning applications with a Light Working Wall and a Cabinet Working Wall connected to the Vertical Post Package, a unique Customer Request (CR) is required. See your Teknion Dealer Support for details.

** Some combinations of fascia elevations require extra Horizontal Connector Bolts (FBN) for connection to the Landscape Horizontal Rail Package. These bolts are available from stripped down verticals on site (beside doors, corners, etc). See your Teknion dealer for details.

step 3

Select the appropriate Portrait elevation type (Full/Monolithic, Segmented, or Working Wall)

step 4

Consider both sides of the Landscape wall when selecting Functional Rail locations (21", 36", 60" and 84" horizontal datums)

vertical post package selector – landscape

To select the appropriate Landscape Vertical Post Package (FLKV) or Landscape to Portrait Vertical Post Package (FLKVP), consult the following chart:

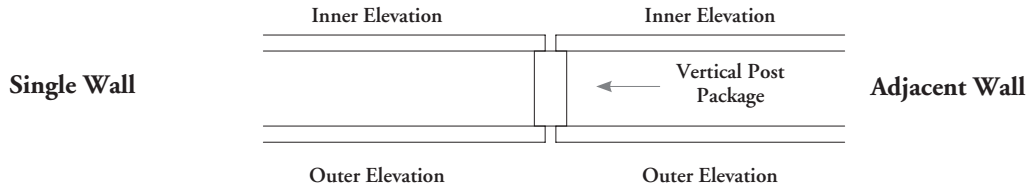

		Single Wall Modules: Inner and Outer Elevations									
		W+W FLKV W	W+L FLKV L	W+C FLKV C	C+C FLKV C	L+L FLKV L	L+C CR	Landscape Aluminum Fascia Kit	Altos Desk W	Altos Desk L	
Adjacent Wall Modules: Inner and Outer Elevations	W+W FLKV W	FLKV W									
	W+L FLKV L	FLKV L	FLKV L								
	W+C FLKV C	FLKV C	CR	FLKV C							
	C+C FLKV C	FLKV C	CR	FLKV C	FLKV C						
	L+L FLKV L	FLKV L	FLKV L	CR	CR	FLKV L					
	L+C CR	CR	CR	CR	CR	CR	CR				
	Land. Alum Fascia Kit	FLKV W	FLKV L	FLKV C	FLKV C	FLKV L	CR	FLKV W			
	Altos Desk W	FLKV W	FLKV L	FLKV C	FLKV C	FLKV L	CR	FLKV W	FLKV W		
	Altos Desk L	FLKV L	FLKV L	CR	CR	FLKV L	CR	FLKV L	FLKV L	FLKV L	
	*Doors	FLKV W	FLKV L	FLKV C	FLKV C	FLKV L	CR	FLKV W	FLKV W	FLKV L	
	*Corners	FLKV W	FLKV L	FLKV C	FLKV C	FLKV L	CR	FLKV W	FLKV W	FLKV L	
	*Wall Starts / *Wall Ends	FLKV W	FLKV L	FLKV C	FLKV C	FLKV L	CR	FLKV W	FLKV W	FLKV L	
	Portrait Fascia	FLKVP W	FLKVP L	FLKVP C	FLKVP C	FLKVP L	CR	FLKVP W	FLKVP W	FLKVP L	
Tek Pier	Tek Pier is not available next to Landscape										

*Verticals beside Altos Doors, Corners, Wall Starts or Wall Ends will be stripped of connectors on one side on site.

base & ceiling channel overview – landscape

A Ceiling Channel is required over the entire wall run, including door openings and corner connections in all applications of the Altos wall system.

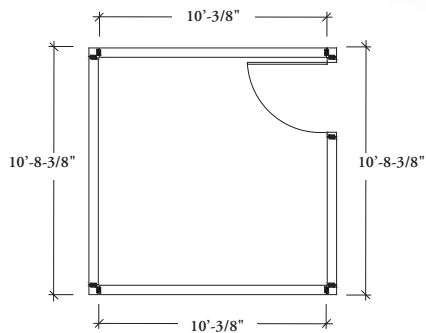
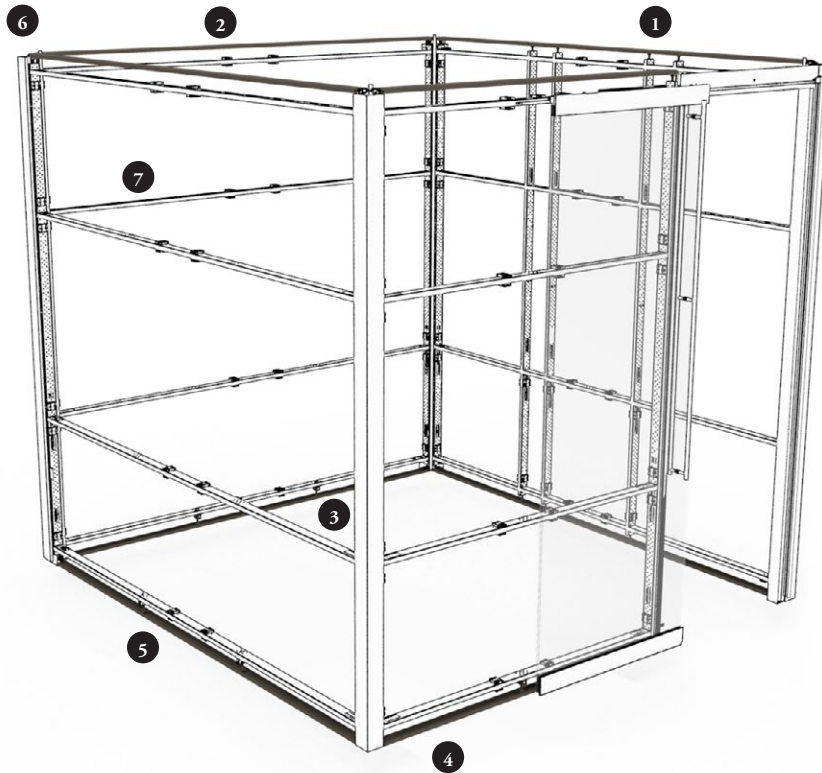

- 1 Ceiling Clip (FKP)
- 2 Ceiling Channel (FKN)
- 3 Horizontal Grommet (FBG)
- 4 Base Channel (FKC)
- 5 Wall Gasket (FKJ)
- 6 Vertical Reveal Cover Kit (FKJC)
- 7 Landscape Horizontal Rail Package (FLKH)

To determine the number of Ceiling Channels (FKN) required for the length of a wall run, take the total linear footage multiplied by 0.14.

base & ceiling channel basics – landscape

A Ceiling Channel is required over the entire wall run, including door openings and corner connections in all applications of Altos wall system.

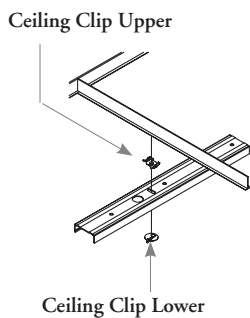
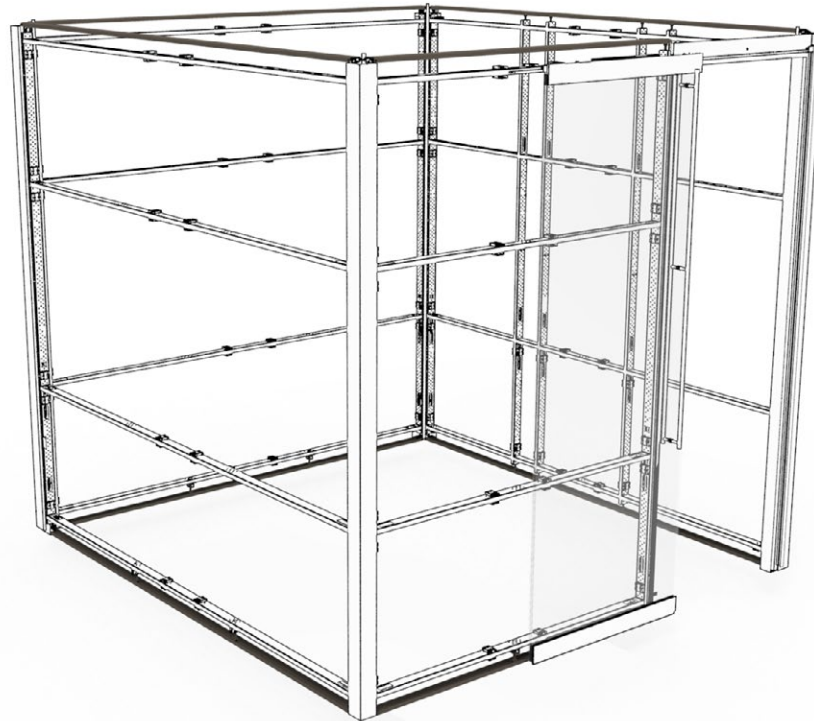

Ceiling Clip (FKP)

- Is a non-permanent method of connecting the ceiling channel to the suspended ceiling
- **Cannot** be connected to all types of ceilings – site verification required
- Non-marking and need to be ordered separately from ceiling channel
- Accommodate the changing wall locations without defacing the T-Bar



Horizontal Grommet (FBG) (not shown)

- The Horizontal Grommet provides a cover to the Horizontal Rail cut outs
- Optional for use with Solid, Fabric Wrapped, Acoustic Tackable, Metal Micro Perforated and Whiteboard fascias. **Cannot** be used with Glass Fascias

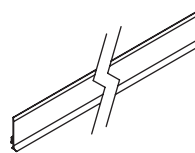

Wall Gasket (FKJ)

- Is a light and sound seal between the bottom of the wall system and the finished floor and the top of the wall system and the ceiling
- Minor height variations in floor and ceiling surfaces may be concealed by the wall gasket – available in 10'-0" lengths only

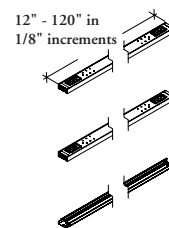

Landscape Horizontal Rail Package (FLKH)

- Consist of horizontal rails and one Landscape Base Channel
- Available in 12" - 120" in 1/8" increments
- Pass-through of electrics and communications is possible through the openings in the horizontal rails
- One Package is shared between the inner and outer elevation of a wall module
- Are universal and are used for all Landscape fascias

Ceiling Channel

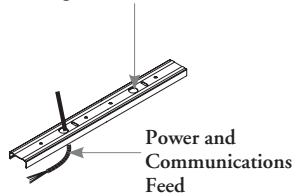

Ceiling Channel (FKN)

- Attaches to the ceiling and supports the Vertical Post Packages
- Is an inverted steel U-channel start and can be cut to size on site
- Holes are punched into the Ceiling Channel to facilitate power and communications feed from the ceiling into the wall
- Is available in 120" lengths only
- Can be attached to ceiling at any angle

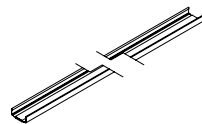

Base Channel (FKC)

- Can be paired with Landscape Horizontal framework
- Gap tape is provided along the underside of the channel to add stability and an acoustic barrier without mechanical attachments to the floors
- Can also be mechanically fastened to the floor if a more secure or permanent attachment is required (hardware not included)
- Available in 120" widths only



Vertical Reveal Cover Kit (FKJC)

The Vertical Reveal Cover provides a trim for vertical post when Platinum or Very White gaskets are used

planning with ceiling clips – landscape

The following should be considered when planning with Ceiling Clips.

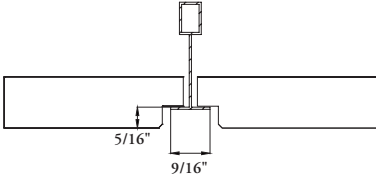
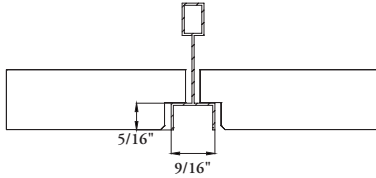
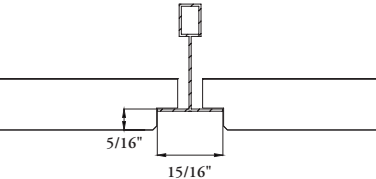
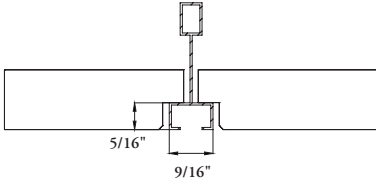
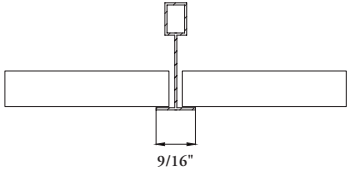
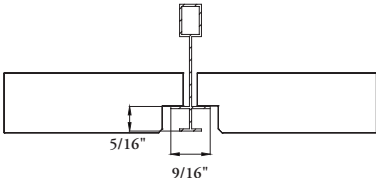
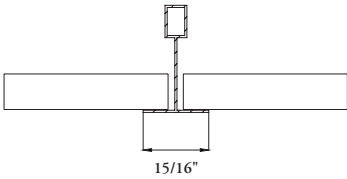
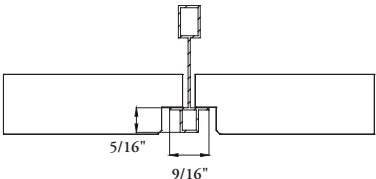
Ceiling Profile	Ceiling Clip	Ceiling Profile	Ceiling Clip
	FKP1 + FKP3		FKP5
	FKP2 + FKP3		FKP5
	FKP1		FKP5
	FKP2		FKP5

- 9/16" and 15/16" Ceiling Clips (FKP1 and FKP2) are used for flat and recessed tiles with flat grid only
- For recessed tile application, Spacer Ceiling Clips (FKP3) is required for use with FKP1 or FKP2
- 9/16" Ceiling Clip (FKP5) is used for recessed tiles with various types of box grid

planning with horizontal rails – landscape

Landscape Horizontal Rail Packages include the appropriate number of horizontal rails and one Base Channel. Each Landscape Horizontal Rail Package corresponds to the fascia elevation it will support. The following chart demonstrates the components included.

Monolithic and Base/Ceiling Fascia elevations use the same Landscape Horizontal Rail Package.

Standard Working Wall

- Functional Rails are available at the 36" and 84" datums

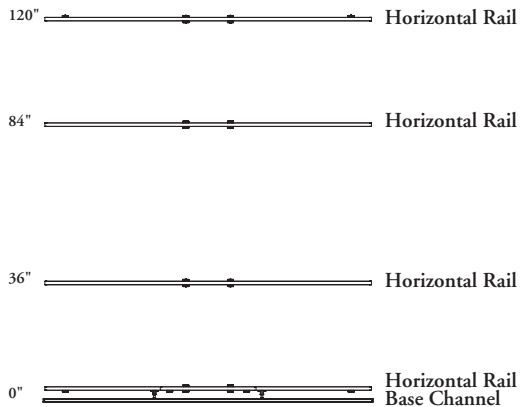

Monolithic or Base/Ceiling Fascia

Light Working Wall

- Functional Rails are available at the 36", 60" and 84" datums

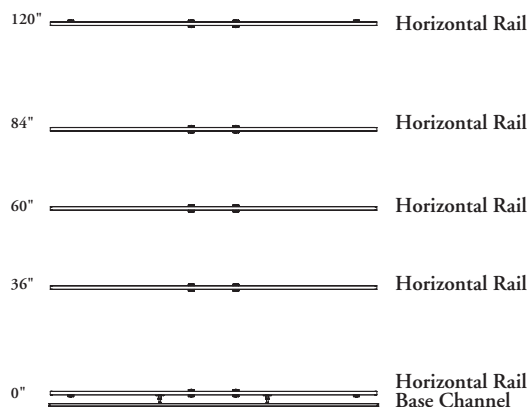

Monolithic or Base/Ceiling Fascia

Cabinet Working Wall

- Functional Rails are available at the 21", 36", and 84" datums

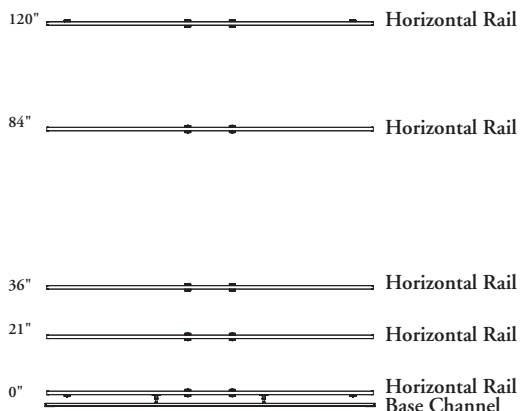

Monolithic or Base/Ceiling Fascia

planning with horizontal rails – landscape (continued)

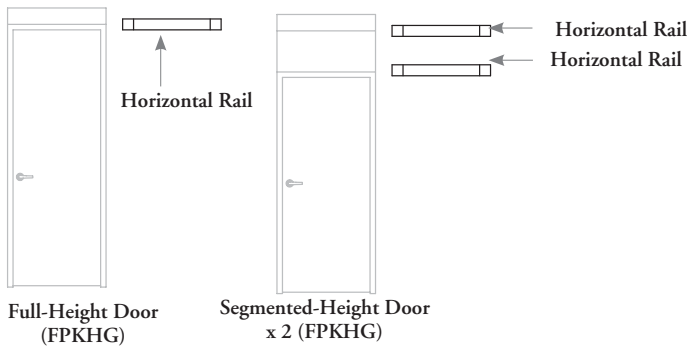

Double Doors require a Double Door Transom & Frame Package as shown:

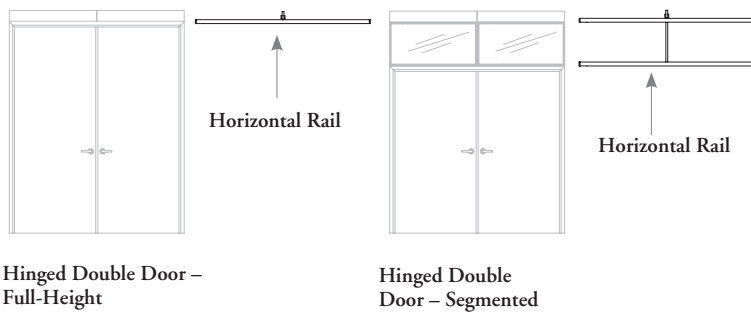

Glass Barn Doors require Landscape Barn Door Rail and Jamb Kits for Full or Segmented heights.

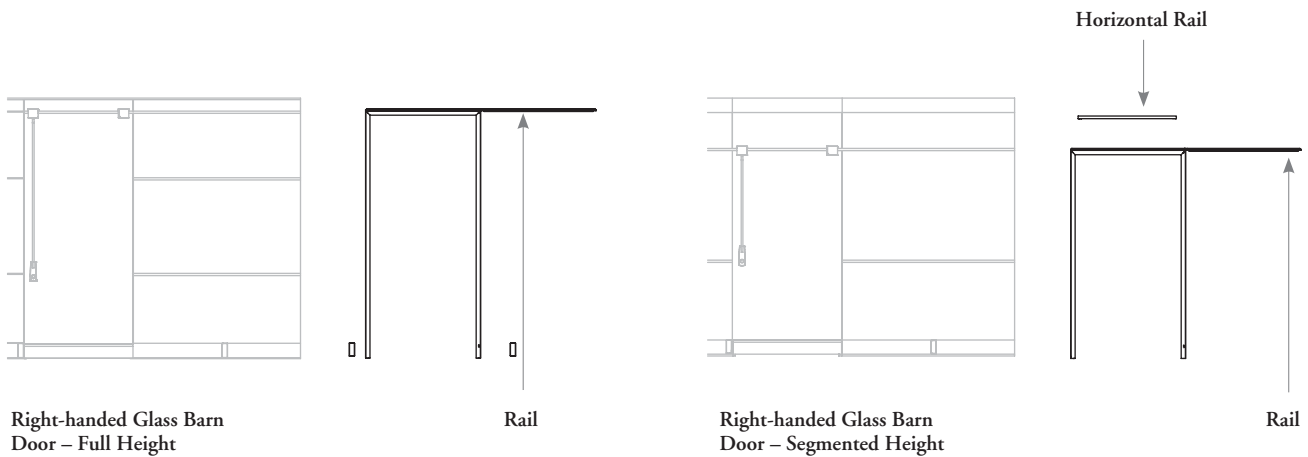

planning with horizontal rails – landscape (continued)

The Landscape Horizontal Rail Package (FLKH) is shared with both sides of the wall, even when the fascia elevation is different. To select the appropriate Horizontal Rail Package, identify the fascia elevation on each side of the wall, and use the chart below.

Landscape Horizontal Rail Package Selection chart:

Fascia Elevation Combinations					
W	C	L	W	W	L
W	C	L	C	L	C
FLKH	FLKH	FLKH	FLKH	FLKH	Additional Components Required*
W	C	L	C	L	
Horizontal Rail Package Required					

Legend:
 Standard Working Wall (W)
 Light Working Wall (L)
 Cabinet Working Wall (C)

* When planning with a Light Working Wall and a Cabinet Working Wall back to back, additional components are required. See your Teknion Dealer Support for details.

Example: Light Working Wall and Standard Working Wall requires Horizontal Rail Package (FLKHL)

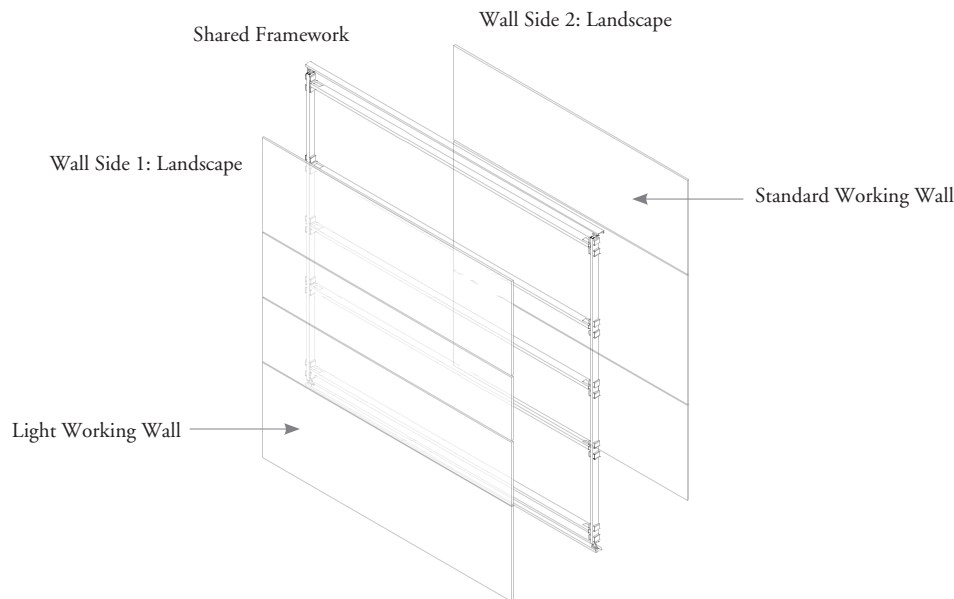

functional rail kit basics – landscape

The Functional Rail provides a universal continuous mounting location for the Altos Landscape shelving and accessories program.

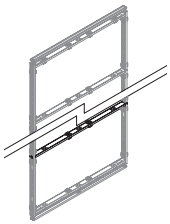
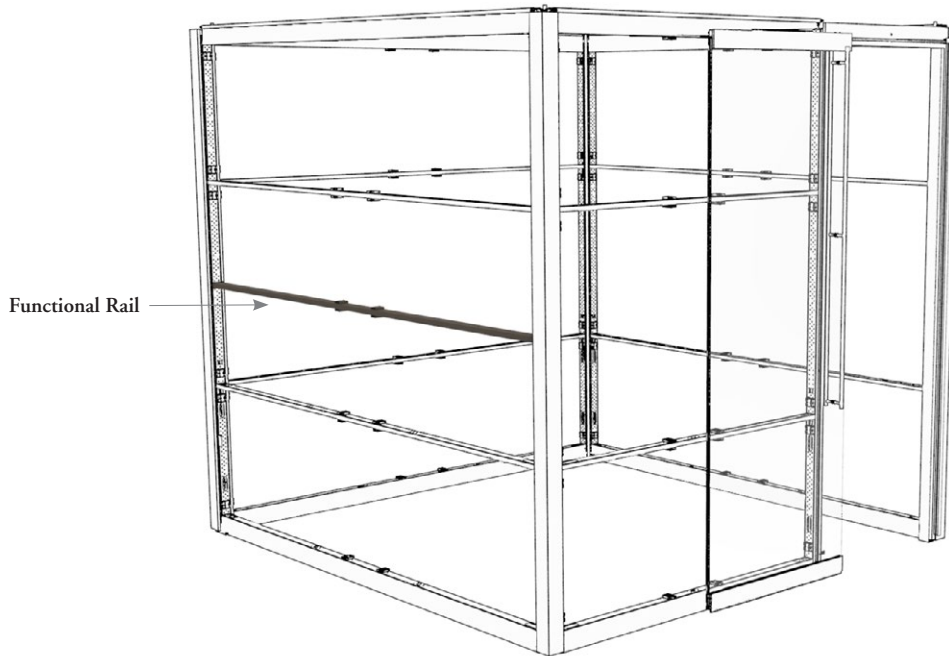

Landscape Functional Rail Kit (FLKF)

- Replaces the Altos horizontal rail where functionality is desired
- Available from 48-1/8" - 120" lengths in 1/8" increments.
- Built-in shelf leveling capability
- Single and Double sided applications
- Able to hold:
 - Landscape Wall-Mounted Cabinets (FLWC)
 - Landscape Shelves (FLSA/FLSG/FLSS/FLTW)
 - Landscape Wall-Mounted Light (ELWML)

desk frame basics – landscape

The Landscape Desk Frame is the support system used to mount the Landscape Desks into the wall module.



Landscape Desk Frame (FLDF)

- Provides a mounting location for both Landscape fixed and height-adjustable desks
- Available as a Working Wall or Light Working Wall
- Heights available include 86" - 120" in 1" increments
- Frame widths available include 60" - 120" in 1/8" increments
- Accommodates desk widths 60" - 84" in 6" increments
- The desk width is always equal or less than the frame width
- Desk location can be specified centered, justified left or justified right

wall gasket basics – landscape

The Wall Gasket (FKJ) provides a light and sound seal between the bottom of the wall system and the finished floor and the top of the wall system and the ceiling.

Minor height variations in floor and ceiling surfaces may be concealed by the wall gasket.

determining wall gasket requirements

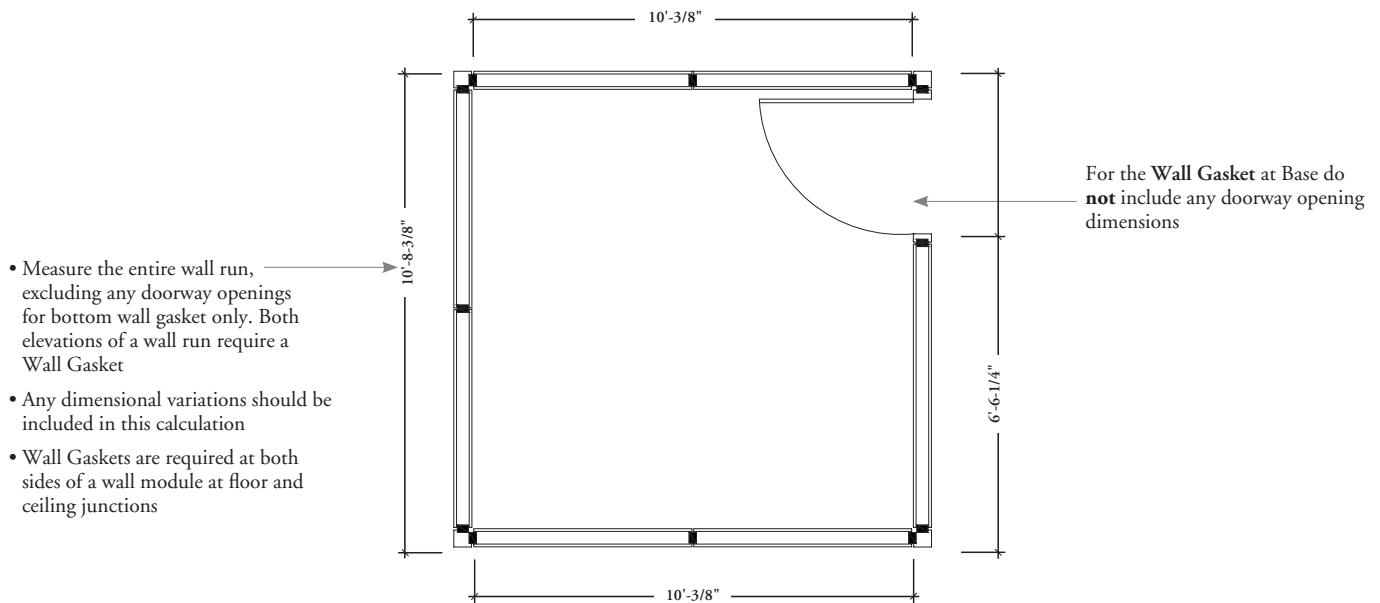

The formula to determine the number of Wall Gaskets (FKJ) required for the length of a wall run is the total linear footage of this product multiplied by 0.40 equals total number of Wall gaskets required.

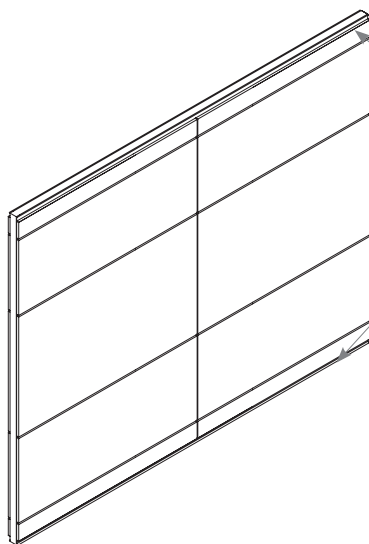

Wall Gasket (FKJ)

- Required at both sides of a wall module at floor and ceiling junctions
- Used as a sound and light seal
- Is not required at the bottom of a doorway opening

fascia reveal inserts – landscape

An optional Black Vertical Reveal Cover Kit (FKJC) is available when planning with Platinum or Very White wall gaskets.

The following outlines the features:

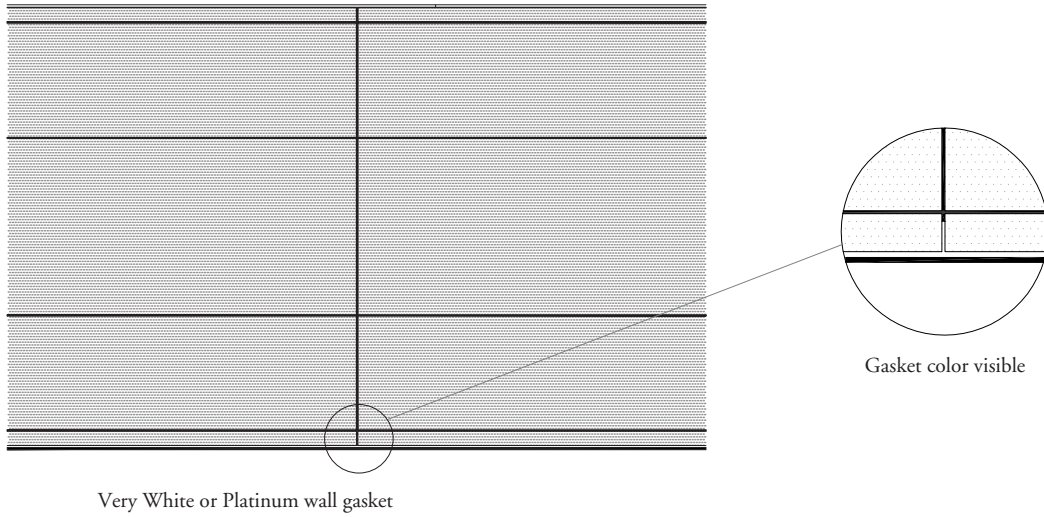

Vertical seams are Black and visible unless finished with a reveal insert

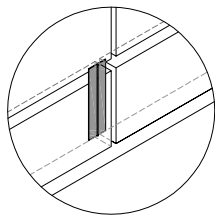

New plastic reveal insert

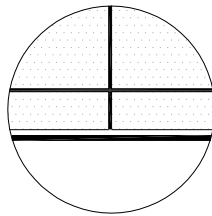

Reveals remain black

The plastic reveal insert is black to match reveal lines.

corner & module connection overview – landscape

Use Altos corners and connections with Altos Landscape fascias to create In-line, two-way, three-way and four-way transitions.

- If applicable, any grain or fabric direction for the corner component will have a vertical directionality like Altos Portrait. Solid or Aluminum corner components can be used if matching the directionality of the adjacent Landscape fascia is desired
- Transitions between Altos corner codes to Landscape fascias do not require use of the Landscape / Portrait Vertical FLKVP. The Landscape Vertical Post Package FLKV can be used
- Partial height connections are not possible
- All connections are available for ceiling heights from 86" to 120" in 1" increments
- The Corner Covers for 135° (FKCN132, FKCN133, FKCN180, FKCN90, FKCN120) can be found in the Fascias Section.

Two-Way 90° Corner Cover (FKCN90) and Hardware for Altos Corner Connections (FKCH90)

Four-Way Corner Connection (FKC4)

Three-Way 180° Corner Cover (FKCN180) and Hardware for Altos Corner Connections (FKCH180)

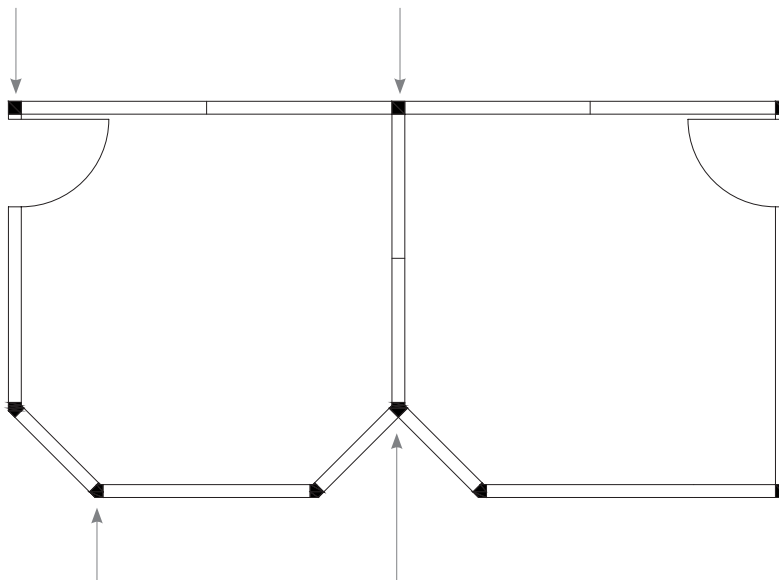

Two-Way 135° Corner Cover (FKCN132) and Hardware for Altos Corner Connections (FKCH132)

Three-Way 135° Corner Cover (FKCN133) and Hardware for Altos Corner Connections (FKCH133)

modular connections

Also Available (not shown):
Two-Way Articulating Corner (FKCA2) and
Three-Way Articulating Corner (FKCA3)

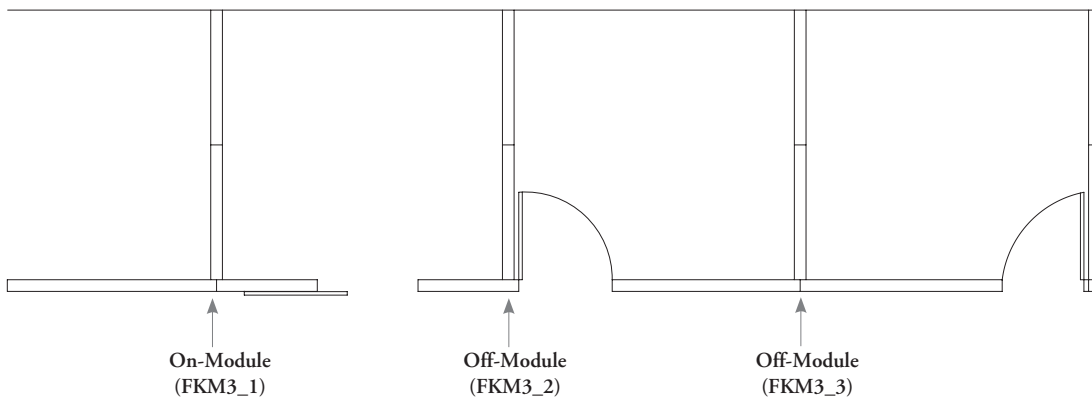

Module Connections create three-way intersections behind the bisected wall

90° corner connection basics – landscape

Walls can be connected at right angles in two-way, three-way and four-way configurations.

- Brackets connect post packages to form a corner
- The quantity of brackets required may vary according to wall heights or wall material
- Can enclose electrics & communications traveling from wall-to-wall or from ceiling down to glass modules
- Covers for two-way and three-way corners are in the Fascias Section

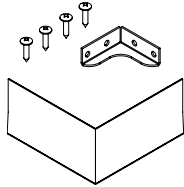

Two-Way 90° Frame Hardware Kit (FKCH90)

Provides the framework to connect two walls at 90°.

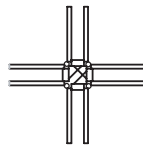

Four-Way Connection 90° Connection (FKC4)

Creates a full-height connection between four walls which are connected at 90°.

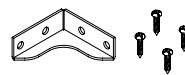
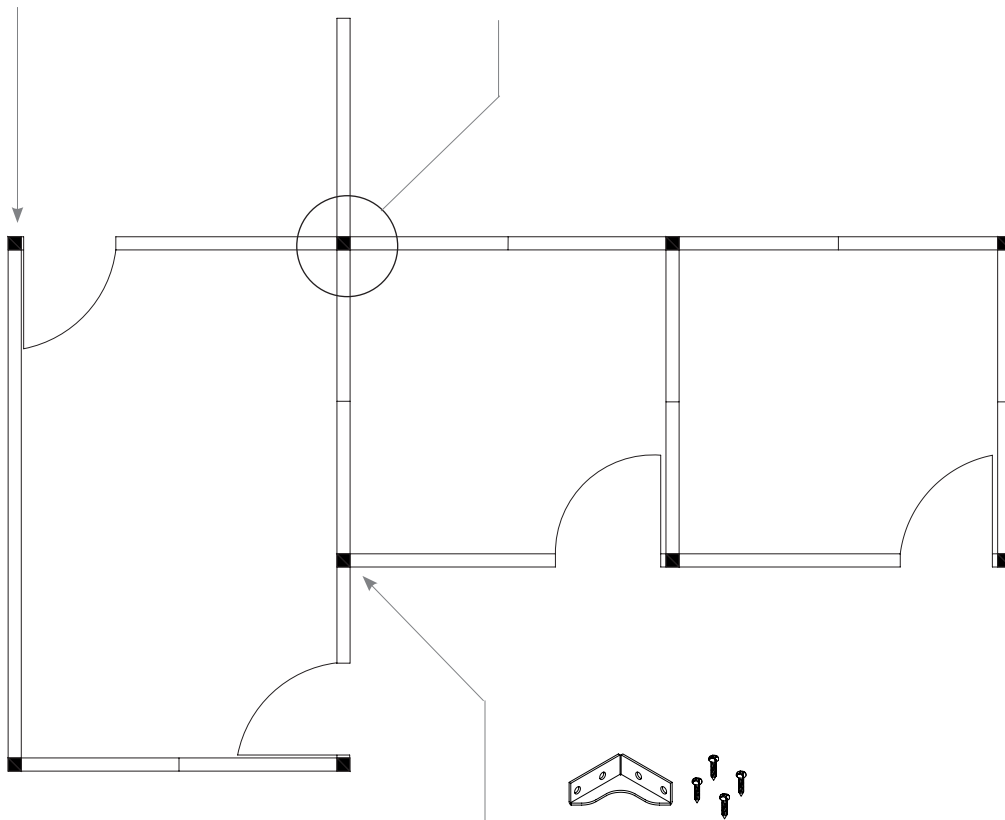

Three-Way 180° Frame Hardware Kit (FKCH180)

Provides the framework to connect three walls at 180°.

planning with 90° corner connections – landscape

The following should be taken into consideration when planning with 90° connections.

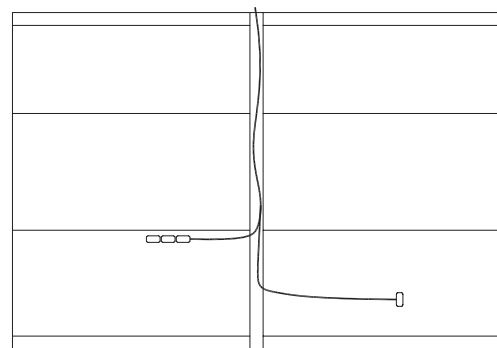
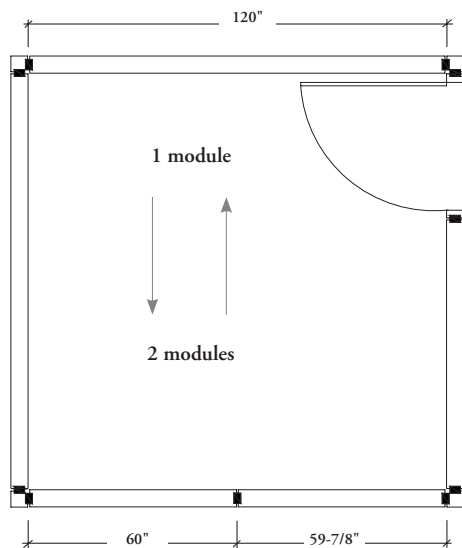
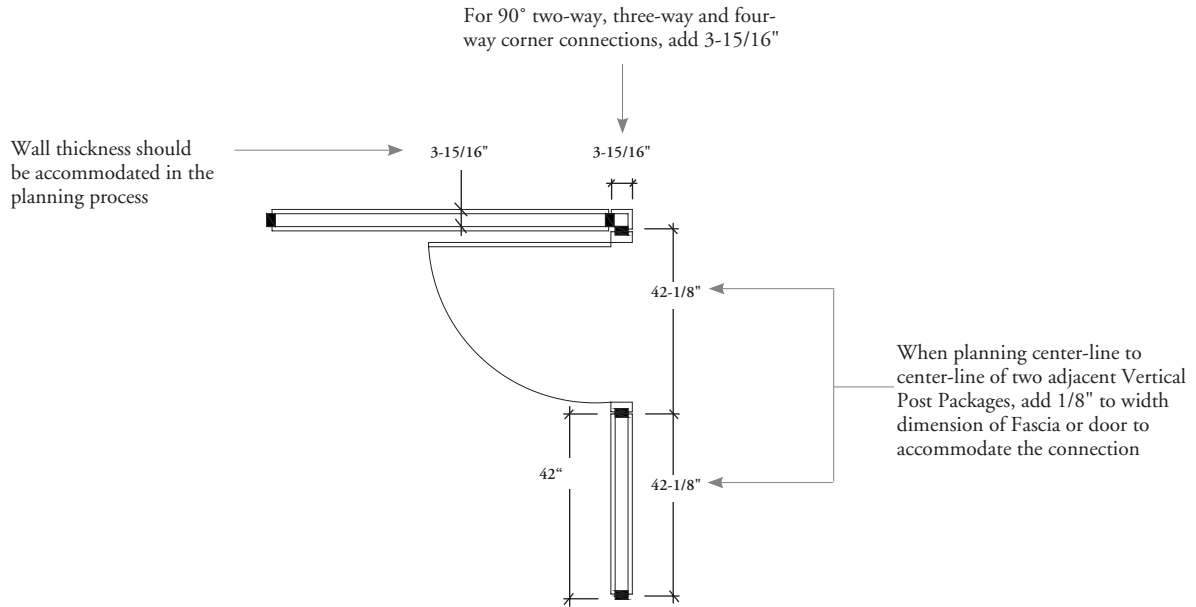

When planning with Landscape in 1/8" increments, and two walls are opposite one another with a wall run between them, the number of wall modules and connections on the opposite walls are not required to be the same.

The total nominal wall width will not be equal for opposite walls when they have a different number of modules. This is due to the fascia creep of the Altos Wall system.

Corner connections enclose electric and communications lines traveling from wall to wall through corners or from the ceiling down to glass modules.

135° corner cover basics – landscape

Walls can be connected at 135° in two-way and three-way configurations.

The Corner Covers for 135° (FKCN132, FKCN133, FKCN180, FKCN90, FKCN120) are in the Fascias Section.

Three-Way 135° Frame Hardware Kit (FKCH133)

Provides the framework to connect to three walls at 135°.

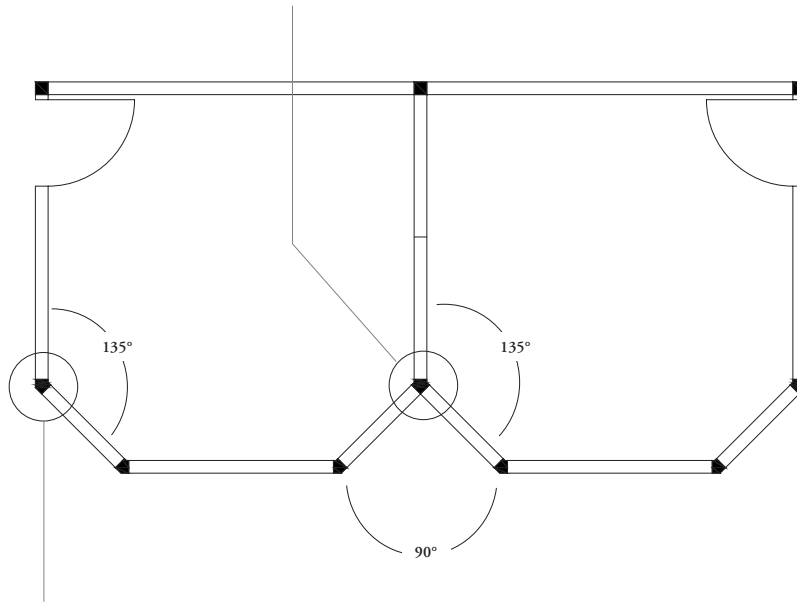
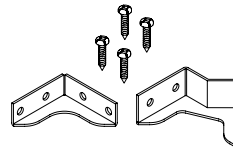

Two-Way 135° Corner Cover (FKCN132)

Provides the frame work for two walls to be connected at 135°.

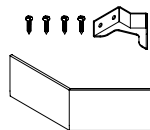

planning with 135° corner covers – landscape

The following should be considered when planning with 135° connectors.

The Altos Desk, shelving, light and cabinets can be suspended from only one adjacent wall module when two wall modules intersect at 135°.

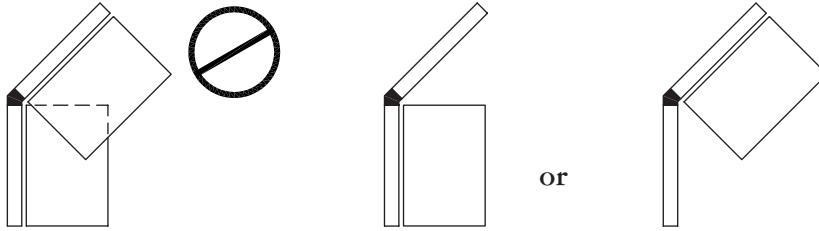

Placement of doors at a 45° does not allow for the suspension of the Altos Desk, shelving, light and cabinets on adjacent wall modules.

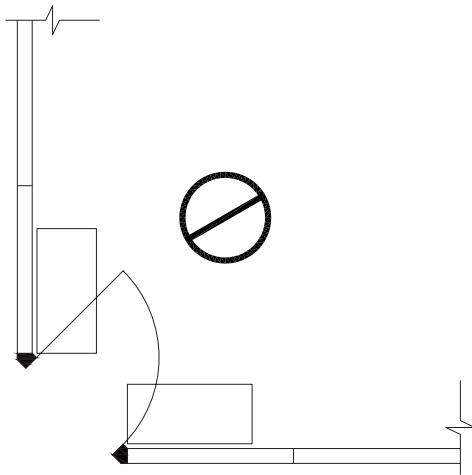

The length of a wall run that includes a 135° connection increases as shown below. Dimensional increase is equal in both directions of wall run.

Two-Way 135° Corner Cover (FKCN132) and Hardware for Altos Corner Connections (FKCH132)

Two-Way 135° Corner Cover (FKCN132) can be found in the Fascias Section.

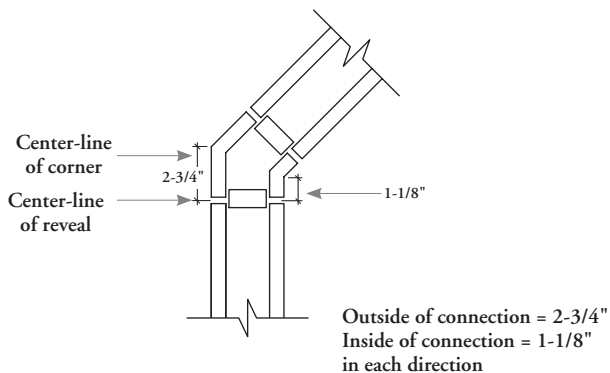

Three-Way 135° Corner Cover (FKCN133) and Hardware for Altos Corner Connections (FKCH133)

Three-Way 135° Corner Cover (FKCN133) can be found in the Fascias Section.

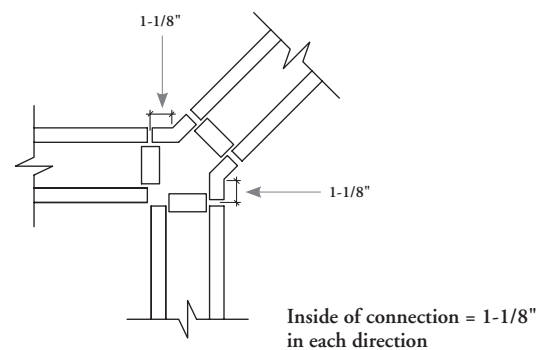

All dimensions are taken from center-line of connection (or point where connection changes direction) to center-line of adjacent reveal between wall modules.

articulating corner basics – landscape

Articulating Corners are used to change the angle of an Altos wall run.

- Articulating Corners are available in two-way and three-way configurations
- All Articulating Corners accommodate a range of adjustment from -10° to $+10^{\circ}$
- Finished in anodized aluminum or painted

Articulating Two-Way Corner (FKCA2)

- Connects two Altos walls between 80° and 100°
- Articulating wall can be on either side of corner
- Provides both the connecting hardware and cover

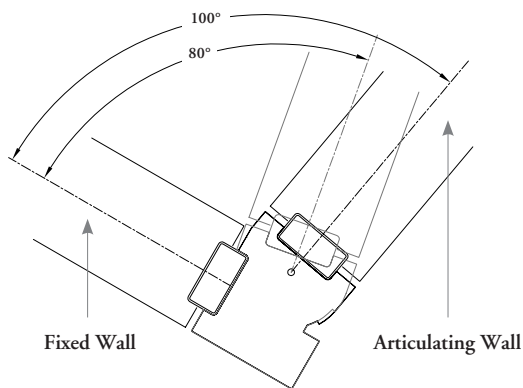

Articulating Three-Way Corner (FKCA3)

- Connects two Altos walls between 80° and 100° with a third fixed Altos wall
- Both sides of corner can be angled independently, each side allows for a maximum 20° of rotation ($\pm 10^{\circ}$)
- Provides both the connecting hardware and cover

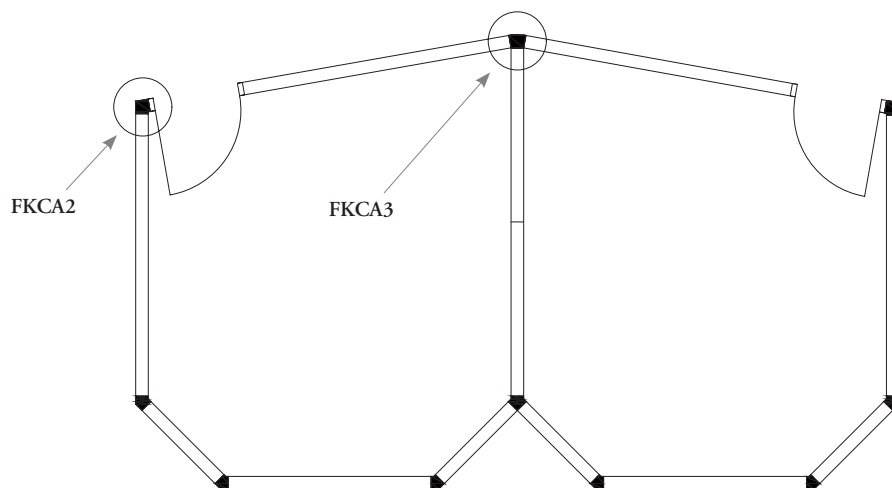
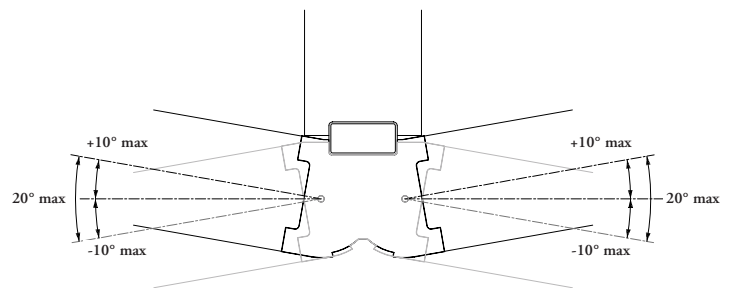

planning with articulating corners – landscape

The following should be considered when planning with Two-Way and Three-Way Articulating Corners.

The Articulating Two-Way Corner is available with two pivot point orientations to indicate which wall is the articulating one.

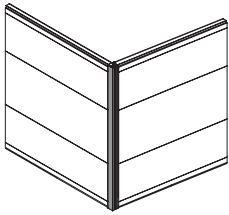

Articulating Two-Way Corner shown with **left** pivot point orientation:

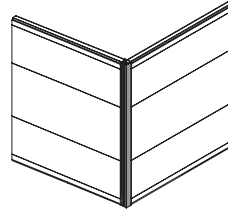

Articulating Two-Way Corner shown with **right** pivot point orientation:

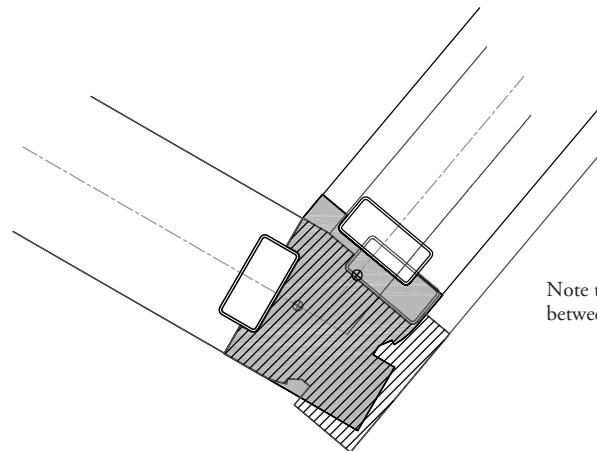
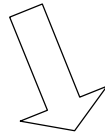
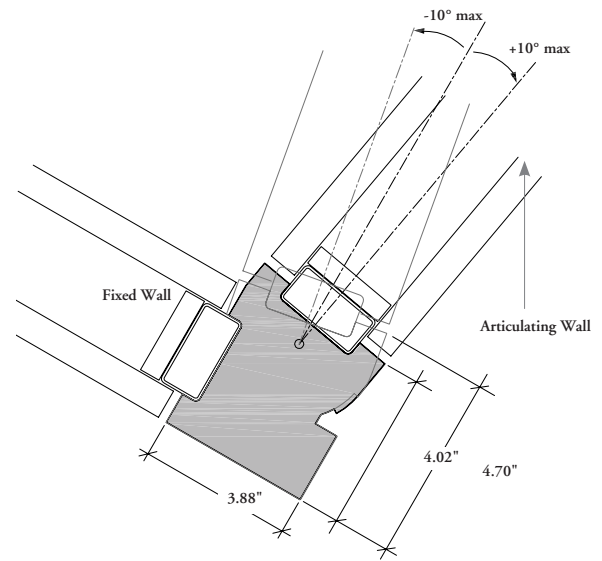
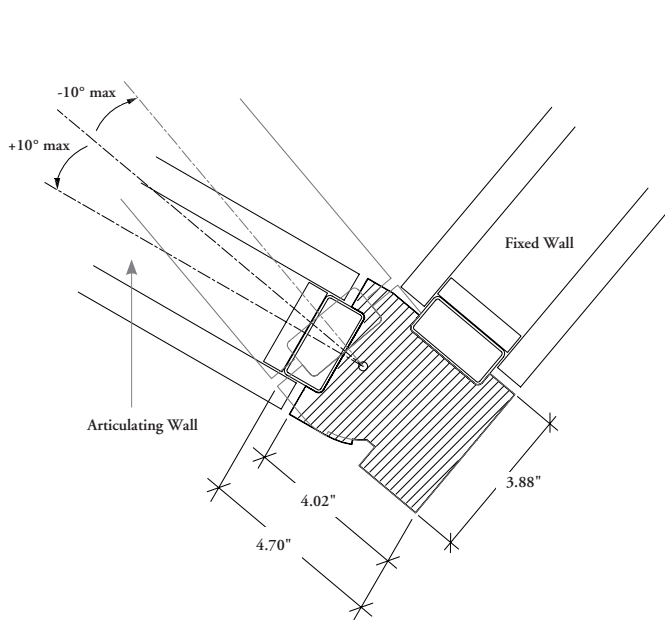

Note the different vertical post positions between left and right pivot point orientation.

planning with articulating corners – landscape (continued)

Articulating Corners restrictions with Barn Door

When a barn door starts on the inside of a fixed wall with an Articulating Corner, the angle between the barn door front wall and the articulating wall cannot be less than 90°.

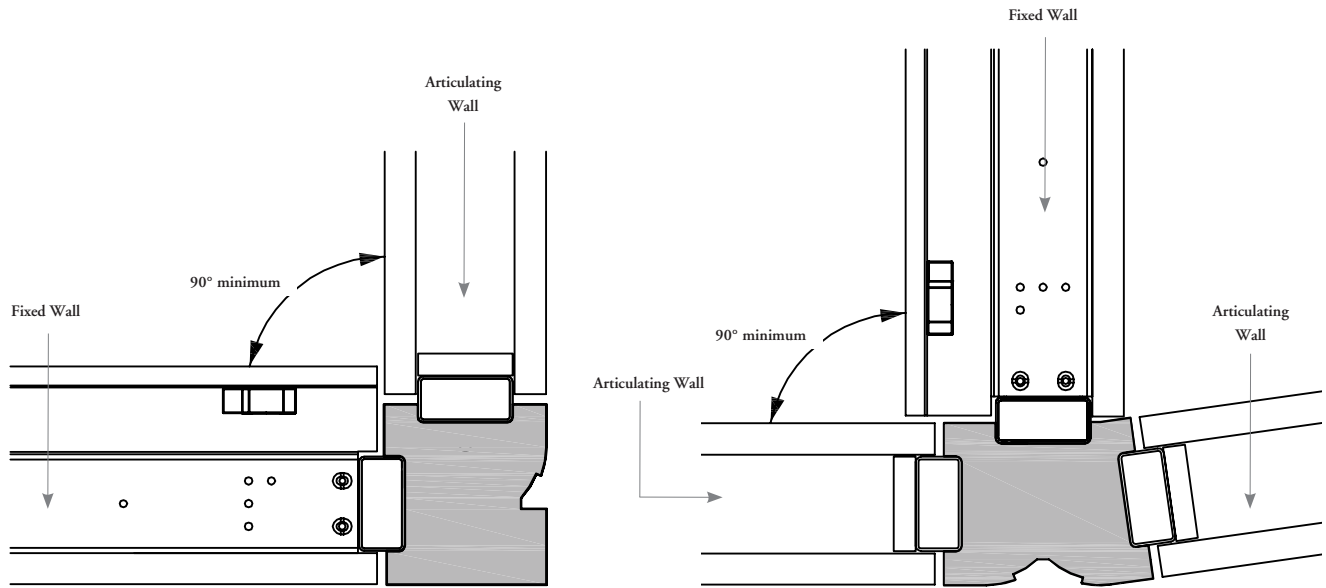

Similarly, when a barn door starts at an articulating wall, the inner angle is restricted to a minimum of 82°.

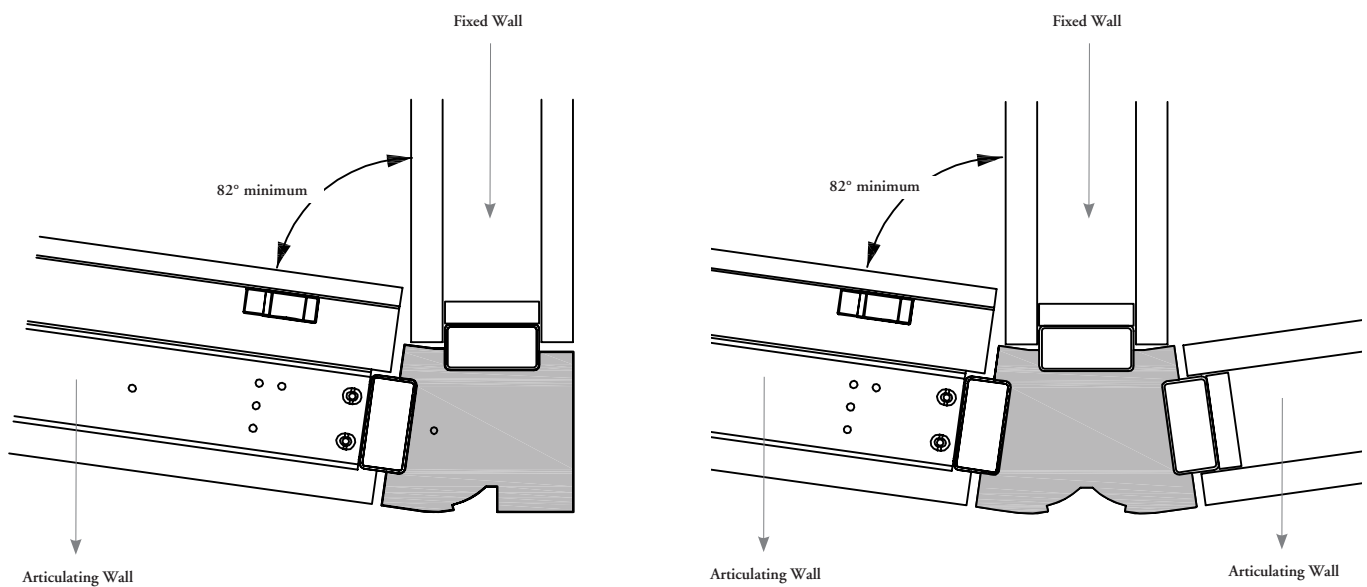

module connection basics – landscape

The Three-Way 180° Module Connection provides options for on and off-module connections to an existing wall run.

Three-Way 180° Module Connection (FKM3_1) (On-Module)

- Centers the connection at the vertical reveal between Fascias
- May **not** be attached at any other location

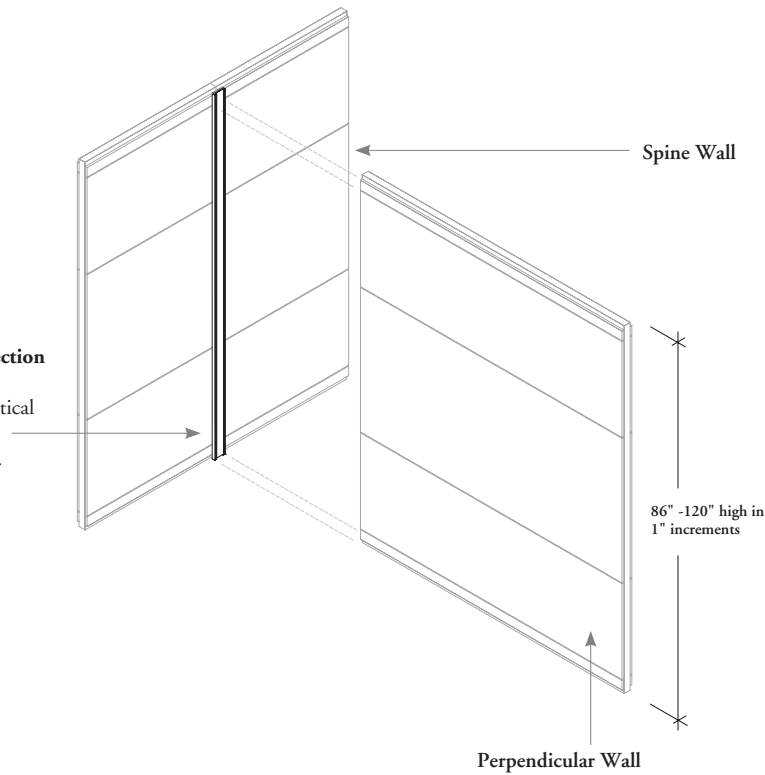

Three-Way 180° Module Connection (FKM3_2) (Off-Module)

- Creates a connection anywhere between reveals of Fascias
- May **not** be used at the vertical reveal
- Can be used at Solid and Double glass Fascias only
- Module Connection adds 1-1/4" Creep – this added dimension comes from the connection interface

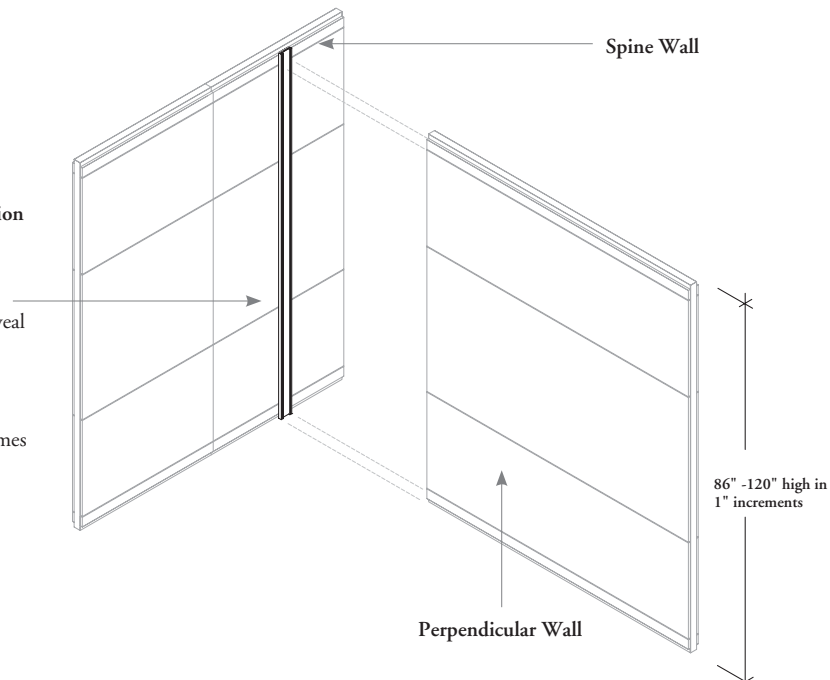

planning with module connections – landscape

The following should be considered when planning with module connections.

Electrics **cannot** be routed through the module connections.

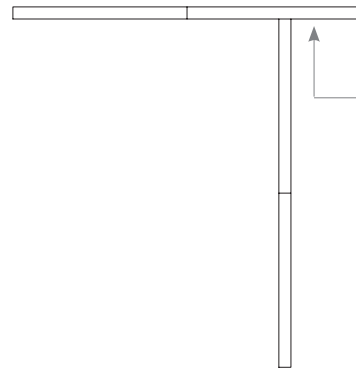

Spine Wall

- Module Connection adds 1-1/4" Creep – This added dimension comes from the connection interface
- There is no creep added in spine wall

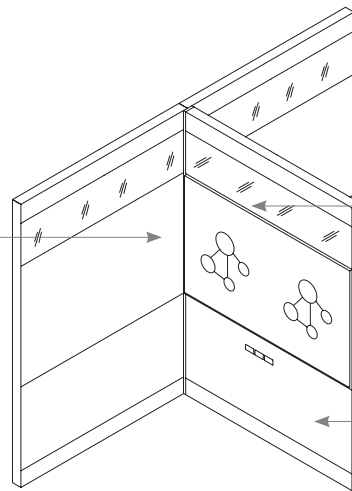

Spine Wall

Off-Module connections may not be connected to a Fascia on the spine wall that is a Whiteboard, Acoustic Tackable, Metal Micro Perforated fascia, or includes a Power Plus Communications Module or any other Power/ Communication cut outs.

Attaching Module Connections to Double Glassed Fascia modules is not recommended as the connector will be visible.

Perpendicular Wall

There are no restrictions for Fascias on the perpendicular wall

Mounting the Landscape Collection

The Landscape desk, shelving and lighting offering is not available planned directly adjacent to a three-way 180° module connection.

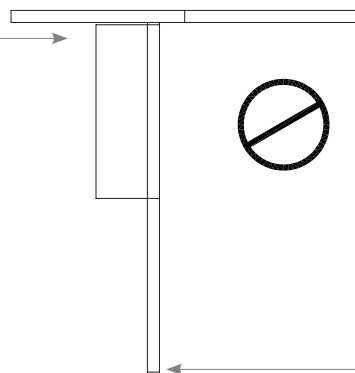

Spine Wall

Perpendicular Wall

For optimum planning, mounted Landscape components should be suspended from the perpendicular wall one module away from the three-way 180° module connection.

planning with module connections – landscape (continued)

Door type and location must be taken into consideration when planning with the Three-Way 180° Module Connection. The following chart shows where each door type can be used on the bisected spine wall.

There are no restrictions for doors located on the perpendicular wall.

Hinged Door,
Hinged Glass Door
Pivot Door
Hinged Double Door

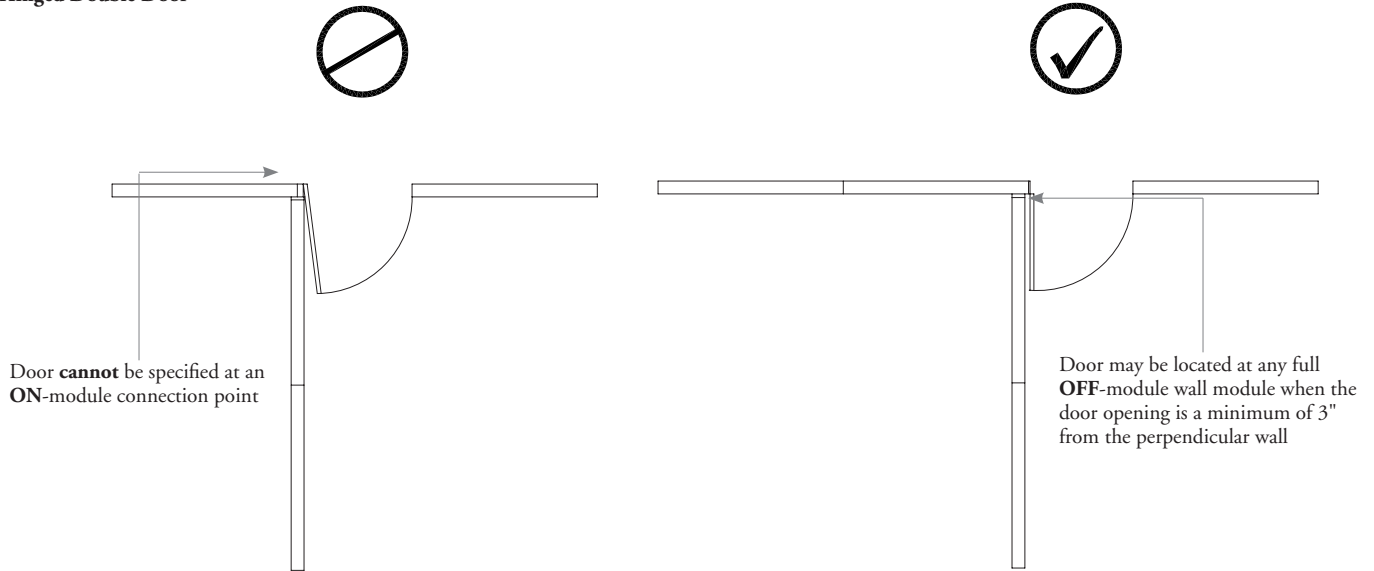

Barn Door

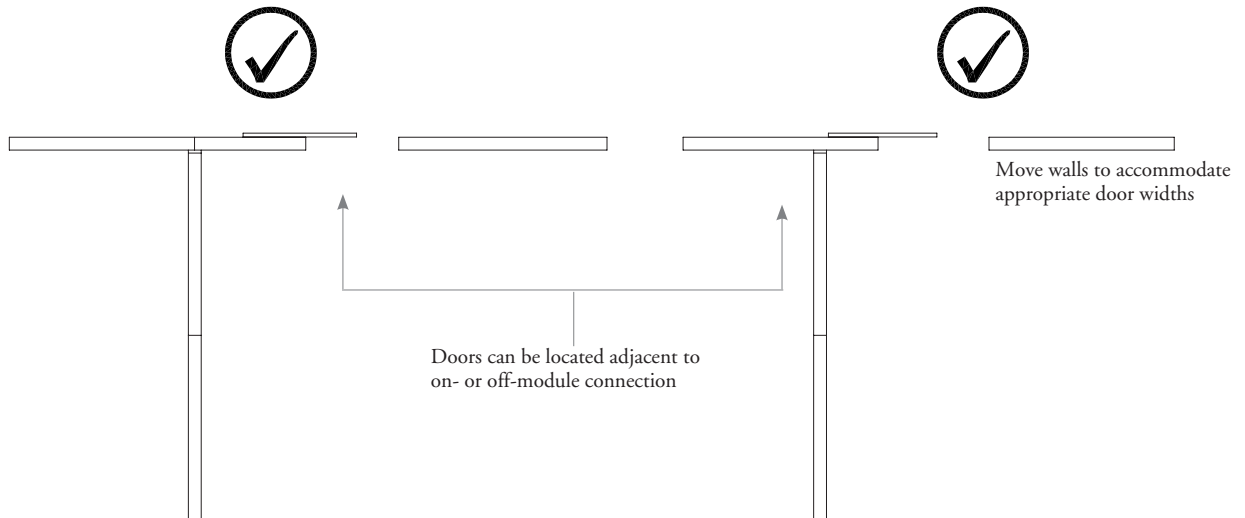

wall start & end basics – landscape

Altos offers three types of wall starts and wall ends for completing Altos runs.

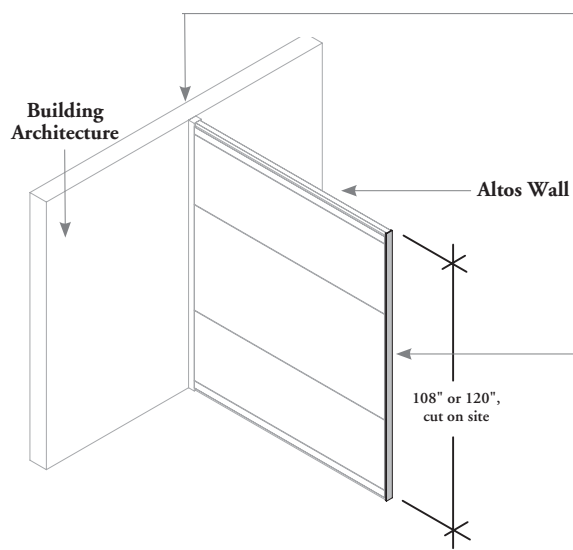

Wall Start (FKW) & Adjustable Wall Start (FLKW)

- Begins or ends a wall run at the building wall, column or mullion and provides a clean connection between the building and the Altos wall
- Can accommodate spacing due to untrue or unlevel wall surfaces
 - Wall Start: +1/4" to -1/4"
 - Adjustable Wall Start: +3/8" to -3/8"
- Adds to the wall run width
 - Wall Start: 1"
 - Adjustable Wall Start: 1-3/4"
- Wall Start can be cut on site
- Wall Start must be used with a Landscape Vertical Post Package when planning with Landscape fascias
- Adjustable Wall Start includes Vertical Post Package
- Does **not** route electrics or communication from the building architecture wall

Wall Finished End (FKF)

- Is used to cap the end of a wall run where there is no connection to another wall run
- Can be cut to size
- Extends from floor to ceiling
- The grain direction will run vertically, if applicable

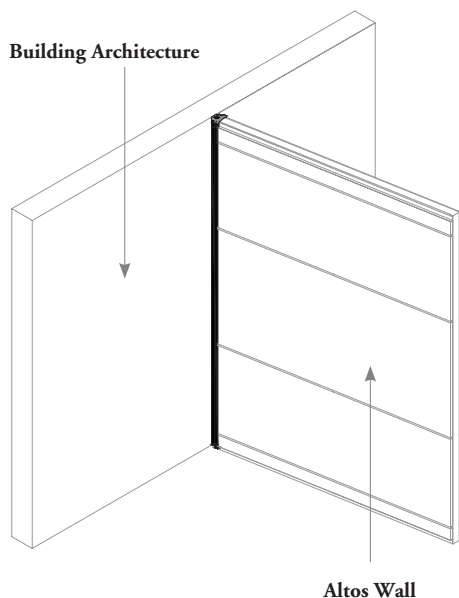

Variable Angle Wall Start (FKWA)

- Used at the beginning or end of a run connecting to building wall, mullion or columns
- Accommodates minor width variation from -1/4" to +3/8"
- When wall start is at nominal position from the building, the Altos wall can start at any angle between -45° and +45°
- When wall start is at minimum position (1/2") from building the Altos wall can start at any angle between -38° and +38°
- Distance between rotation point of wall start and building wall is 3/4"
- Distance between rotation point of wall start and centerline of the first vertical post is 2"
- Must be used with a Landscape Vertical Post package when planning with Landscape fascias
- Does **not** route electrics or communications from the building architecture
- Finished in anodized aluminum or painted

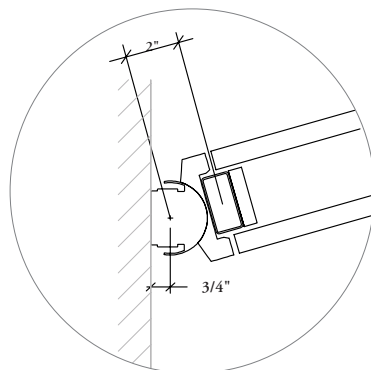
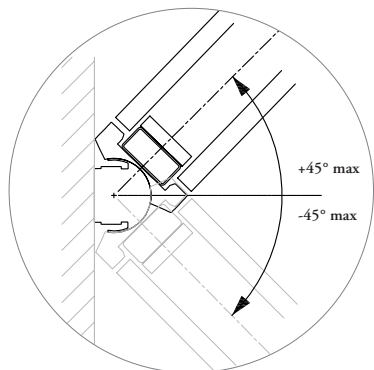

Nominal Adjustment

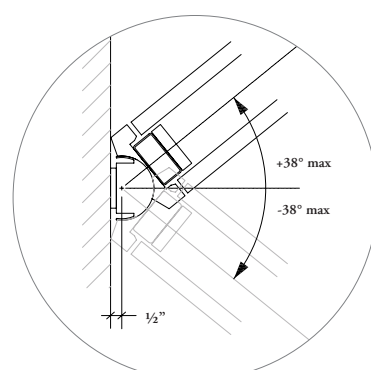

Minimum Adjustment

frame kit component basics – landscape

Altos frame kits come with all necessary connection components however, certain components can also be purchased individually if required. See Price & Product Guide for details of these products.

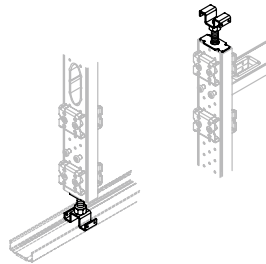

Base Levelers (FBB)

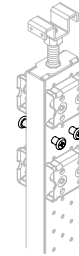

Horizontal Shoulder Screw (FBN)

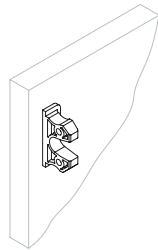

Fascia Connector – Male (FBFM)

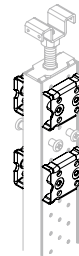

Fascia Connector – Female (FBFF)

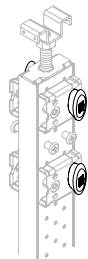

Fascia Lock (FKL)

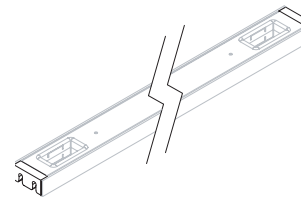





Horizontal End Cap (FBE)

door frame basics – landscape

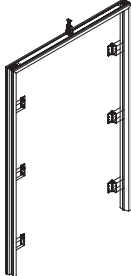
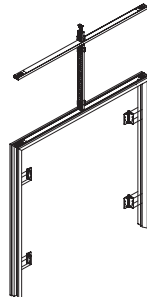
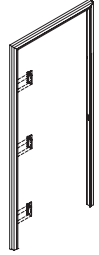
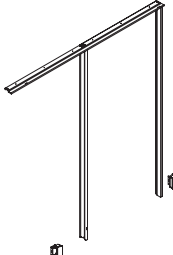
Several frame packages are available for door packages. See price pages for details of these products.

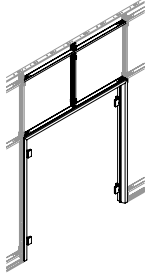
- It is not recommended to install a door adjacent to a Wall Start (FKW) or Filler Panel (FPF)
- If Fascias are required to complete assembly they must be specified separately

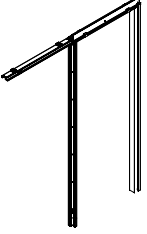
 <p>Double Door Frame – Full Height (FKTF/FPFDS) Required for Full Hinged Double Door (FDD/FPDD)</p>	 <p>Double Door Transom & Frame – Segmented Height (FKTS) Required for Segmented Double Door (FDD/FPDD) at Segmented Height</p>	 <p>Door Frame Kit for Full or Segmented Height (FKD) and Door Frame Kit for Full Height (FPFJS/FPFHS) Required for Full or Segmented Hinged Door (FDH/FPDH) or Glass Door (FDJ/FPDJ)</p>
 <p>Landscape Barn Door Rail Kit for Full-Height Door (FLBFR) and Landscape Barn Door Jamb Kit for Full-Height Glass Door (FLBGFJ) Required for Full Height Glass Barn Door (FDC)</p>	 <p>Landscape Barn Door Rail Kit for Segmented-Height Door (FLBSR) and Landscape Barn Door Jamb Kit for Segmented-Height Glass Door (FLBGSJ) Required for Segmented Glass Barn Door (FDC)</p>	 <p>Hinged Glass Double Door Transom & Frame Package – Segmented Height (FKTES) Required for Segmented Hinged Glass Double Door (FDE/FPDE)</p>
 <p>Glass Pivot Door Solid Frame Kit for Full or Segmented Height (FKPSZ) and Glass Pivot Door Solid Frame Kit for Full Height (FPFPS) Required for Framed Glass Pivot Door (FDPZ/FPDPZ)</p>	 <p>Landscape Barn Door Rail Kit for Full-Height Door – Low Profile (FLUGFR) and Landscape Barn Door Jamb Kit for Full-Height Glass Door – Low Profile (FLUGFJ) Required for Full Height Landscape Glass Barn Door (FDCZ)</p>	

landscape –
lighting, electrics &
communications

landscape – lighting, electrics & communications

LIGHTING OVERVIEW – LANDSCAPE	272
LIGHT SWITCH BASICS – LANDSCAPE	273
WALL-MOUNTED LIGHT BASICS – LANDSCAPE	274
PLANNING WITH WALL-MOUNTED LIGHTS – LANDSCAPE	275
ELECTRICS & COMMUNICATIONS OVERVIEW – LANDSCAPE . .	284
HARDWIRE ELECTRICS & COMMUNICATIONS BASICS – LANDSCAPE	286
PLANNING WITH HARDWIRE ELECTRICS & COMMUNICATIONS – LANDSCAPE	287
POWER PLUS COMMUNICATIONS MODULE ELECTRICS BASICS – LANDSCAPE	288
PLANNING WITH POWER PLUS COMMUNICATIONS MODULES – LANDSCAPE	289
POWER PLUS COMMUNICATIONS MODULE COMPATIBILITY CHART – LANDSCAPE	290
SPECIFYING ALTOS ELECTRICS & COMMUNICATIONS – LANDSCAPE	292
POWER/COMMUNICATION FASCIA CUT OUTS – LANDSCAPE . .	293
DETERMINING ELECTRICS & COMMUNICATIONS REQUIREMENTS – LANDSCAPE	294

lighting overview – landscape

Altos Landscape offers integrated lighting solutions that take advantage of the wall for wire routing and structural support.

Light Switch (ELS)

Allows for user control of individual office ambient light or as a Remote Switch with the Landscape Wall Mounted Light (ELWML).

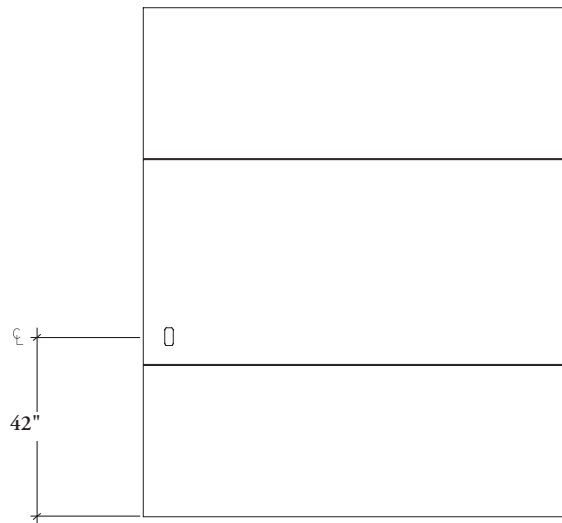
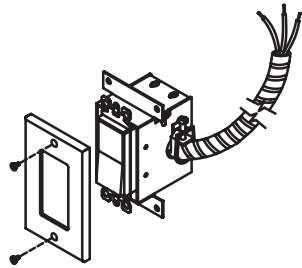

Landscape Wall-Mounted Light (ELWML)

Provides lighting capability in task and ambient modes and can be mounted on the 60" or 84" horizontal datum.



Landscape Wall Mounted Light

light switch basics – landscape

Altos Landscape offers integrated lighting solutions that take advantage of the wall for wire routing and structural support.

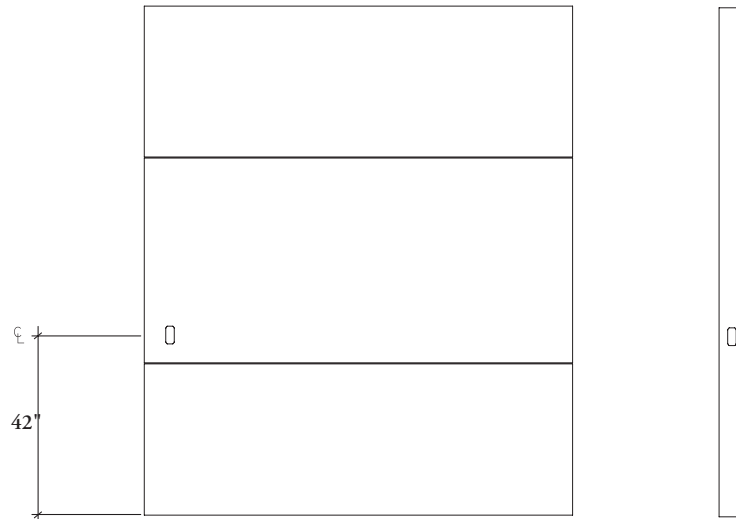
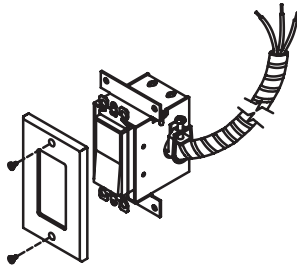

Light Switch (ELS)

- Field installed on Landscape Solid and Fabric Wrapped Fascias and are cut on-site
- Can also be mounted to the Landscape Aluminum Fascia Kit (FLFK) at 42"
- Can be used as Remote Wall switch with Landscape Wall-Mounted Light (ELWML)
- It is recommended to locate the cut out 42" above finished floor, except when above a desk (46")

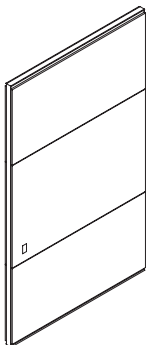

Working Wall Monolithic

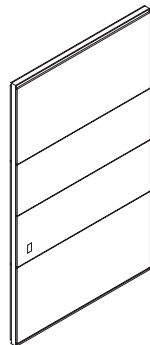

Light Working Wall Monolithic

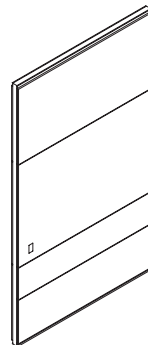

Cabinet Working Wall Monolithic

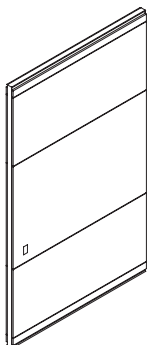

Working Wall Base/
Ceiling Fascias

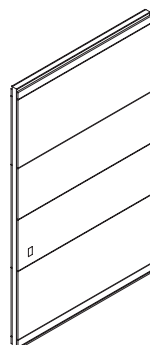

Light Working Wall
Base/Ceiling Fascias

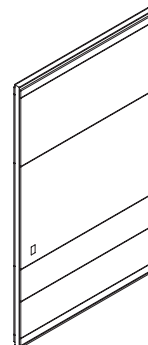

Cabinet Working Wall
Base/Ceiling Fascias

wall-mounted light basics – landscape

The Landscape Wall-Mounted Light provides a lighting solution for both task and ambient lighting within a workspace.

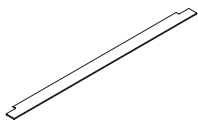
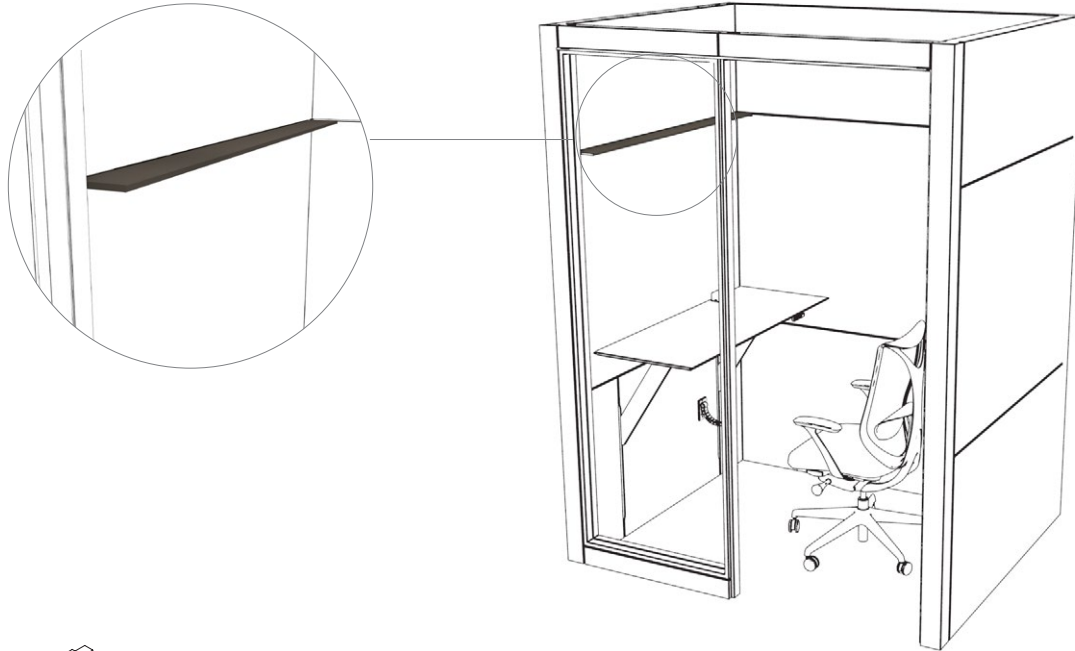

Landscape Wall-Mounted Light (ELWML)

- Can be mounted to either the 60" or 84" horizontal datum using a Functional Rail
- Available 4" deep x 48-1/8" - 96" long in 1/8" nominal increments
- Select finishes available include:
 - Paint: Foundation, Accent, Mica
 - Clear Anodized

switch options available:

Touch Sensitive Switch (left or right)

- Touch activated step dimming button located beside the lens
- Left handed light shown

Remote Wall-Mounted Switch

- Wall-Mounted Light Switch (ELS) can be connected to nearby Solid or Fabric Wrapped Fascia, or Landscape Aluminum Fascia Kit (FLFK)
- Left handed light (shown)

No Switch

- For building integrated solutions (connected to building power)
- Left handed light (shown)

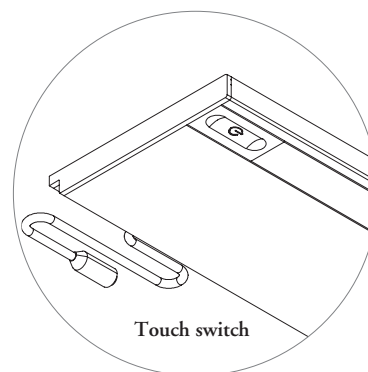

planning with wall-mounted lights – landscape

The following should be considered when planning with Landscape Wall-Mounted Lights.

The Landscape Wall-Mounted Light is available on either the 60" or 84" datum.

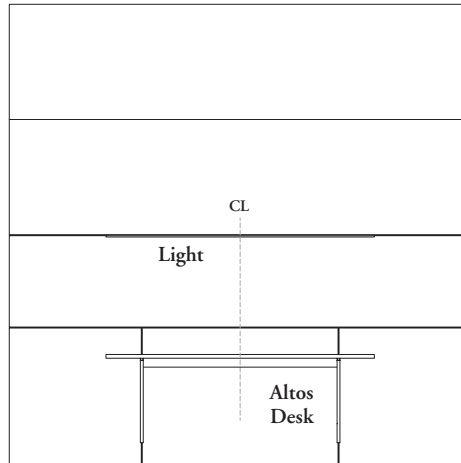
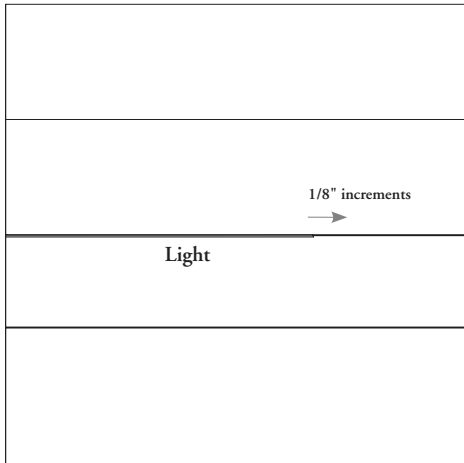

Placement horizontally on a wall

- The Landscape Wall-Mounted Light can be installed on the Functional Rail in 1/8" increments along the horizontal reveal
- The light's nominal width must be equal to or less than the nominal width of the fascia

Placement above a desk

- When planning with a Landscape Desk and Wall-Mounted Light the light must align with the desk's centerline and must be the same nominal width as the desk

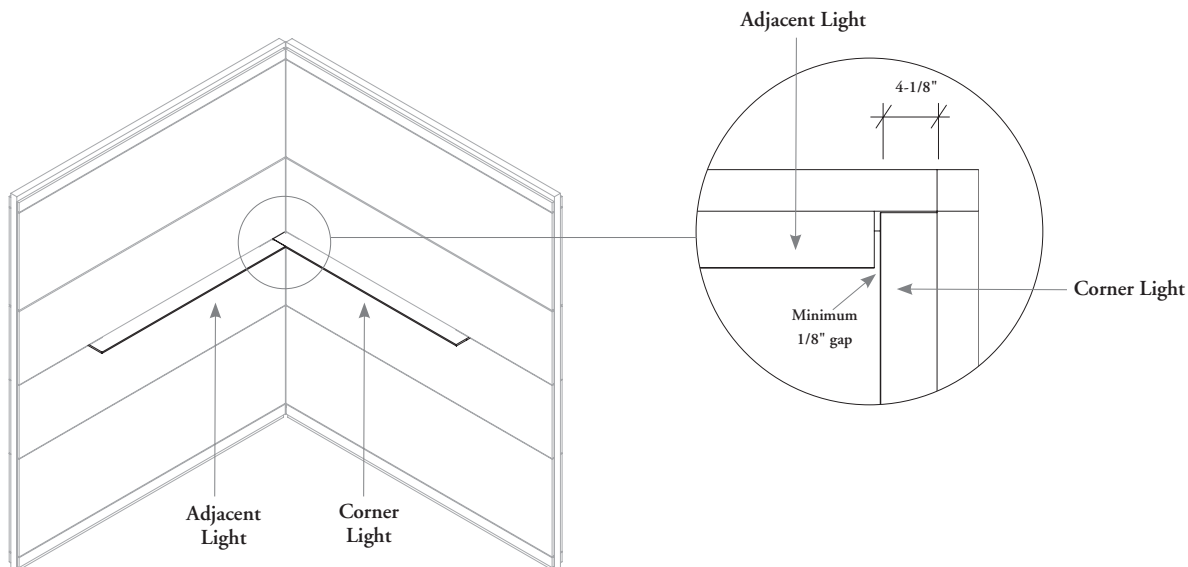

Placement in a corner

- When planning two Lights in a corner wall module the adjacent Light must be specified to be a minimum of 4-1/8" from the edge of the wall module to accommodate the Lights depth as well as a 1/8" gap.

planning with wall-mounted lights – landscape (continued)

The Landscape Wall-Mounted Light can be mounted in two different applications; task and ambient.

Task Light

- Aims downward, casting direct light onto a workspace, whiteboard or other fascia below

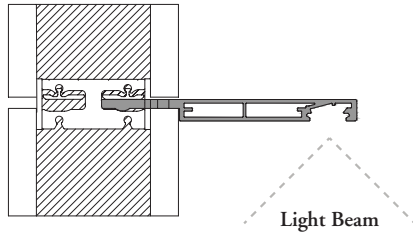

Ambient Light

- Aims upward, reflecting ambient light off a ceiling and upper fascia
- Functional Rail is mounted upside down for the ambient application

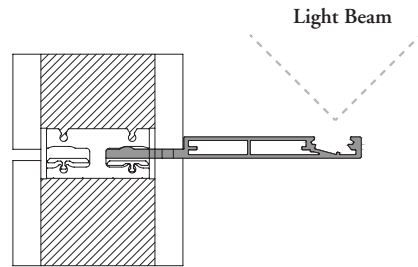

When Landscape Wall-Mounted Lights are planned back-to-back they must be specified as the same application on both sides of the wall.

Task and Task

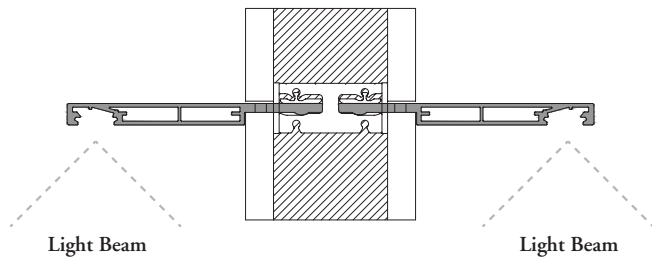

Task and Ambient

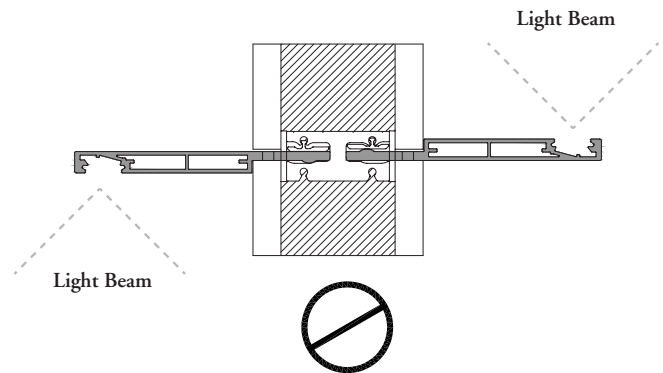

planning with wall-mounted lights – landscape (continued)

- Handedness for both task and ambient applications is determined by the location of the wire exit when the user is facing the wall.
- When specifying a Light with a Touch Sensitive Switch, the switch will be located on the same side of the light as the wire exit.
- When planning a Light without a Desk, cables run along the horizontal and vertical fascia reveal before entering the wall before the floor or ceiling plane.
- Cables in the reveal can be managed with Landscape Light Wire Management (ELWMG).

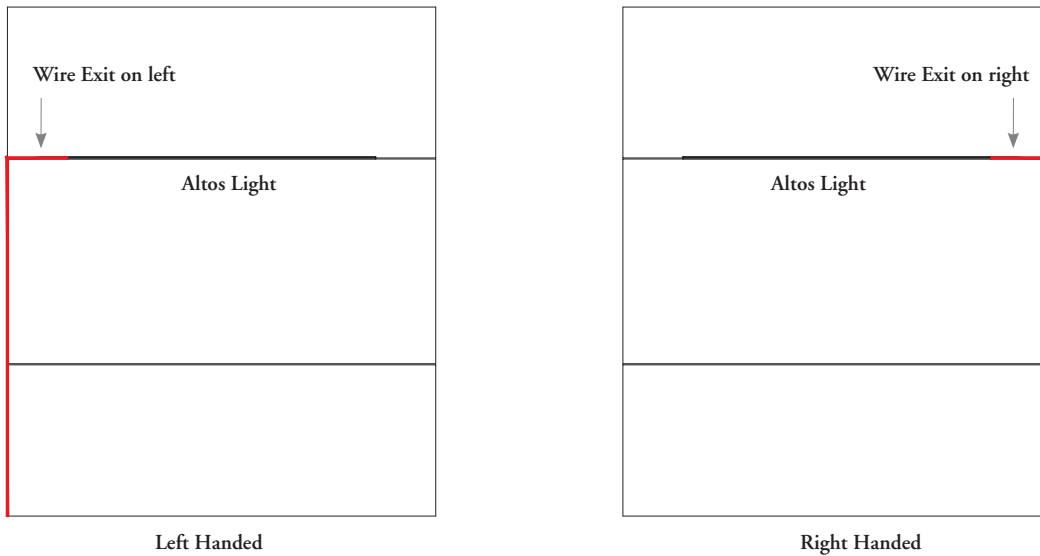

Left handed Lights have wire exits on the left when facing the wall.

Right handed Lights have wire exits on the right when facing the wall.

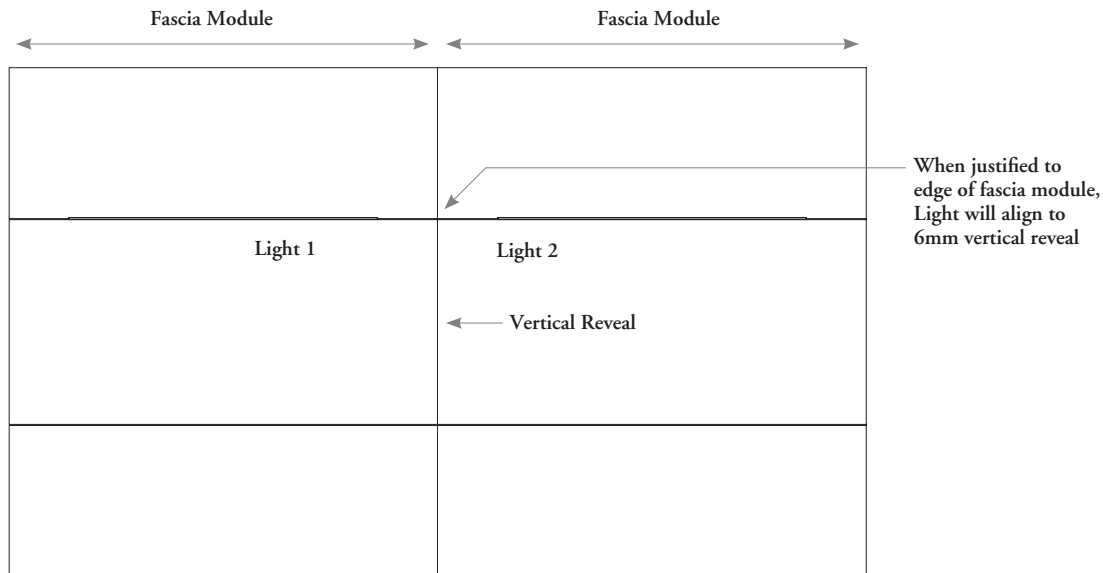

- A Wall-Mounted Light can only be planned with one light per fascia module. If two fascia modules are side-by-side a light can be specified on each module but they **cannot** share the same vertical reveal for wire management
- Lights **cannot** span across a vertical reveal

planning with wall-mounted lights – landscape (continued)

Altos Landscape electrics are available in a base or ceiling feed condition. The following outlines the electrical routing scenarios encountered when planning with Landscape electrics.

electrical routing scenarios:

Electrical Box (No Functional Rails)

- Various Altos power and communications modules are available in the locations shown below
- Power and communications electrics are always routed independently from the Altos Landscape Light or Desk
- If the electrical feed must bypass a Functional Rail or a Glass Fascia, refer to scenario on bypassing Functional Rail or Glass Fascia

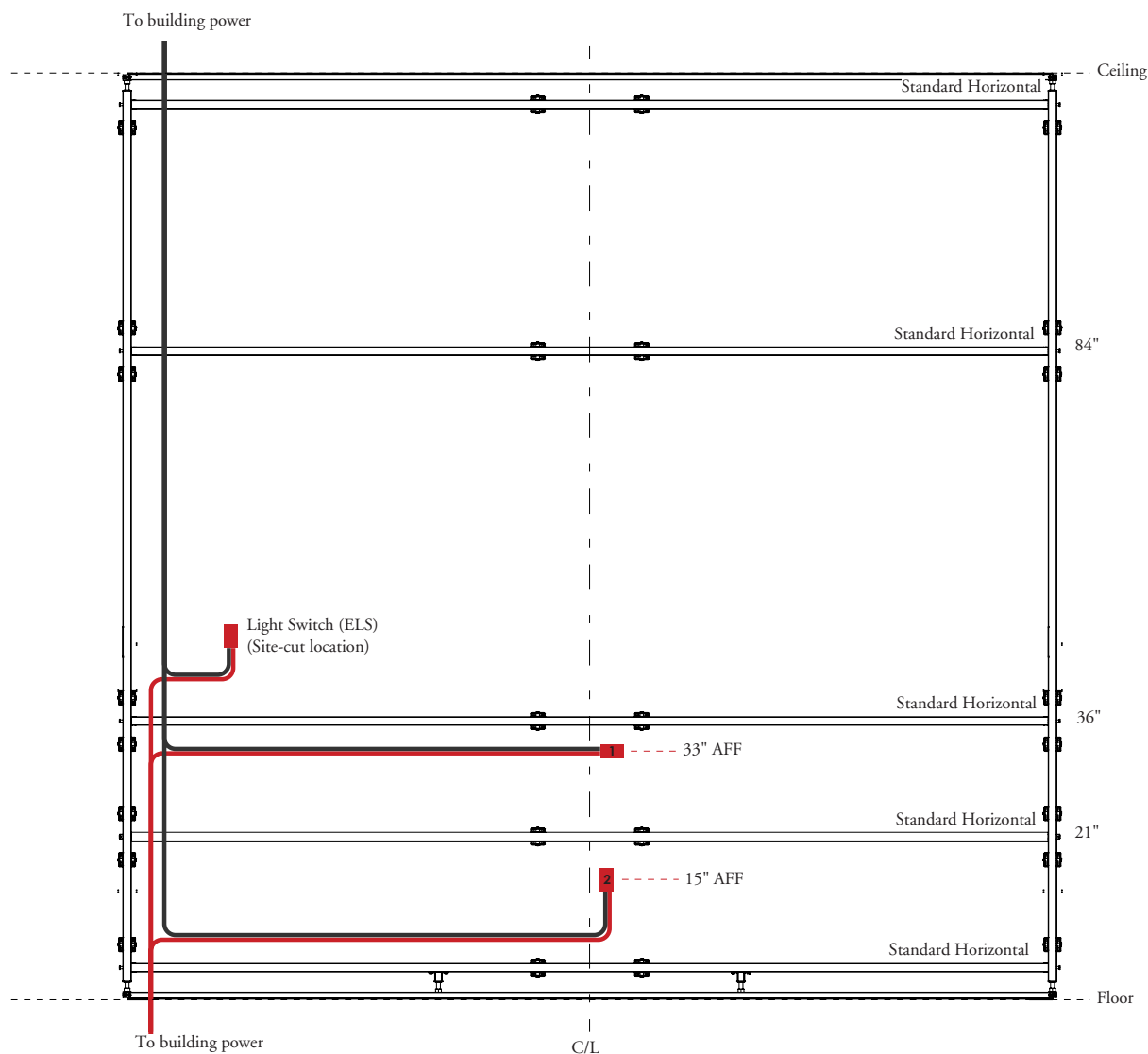

1. Worksurface Height Cut-out for:
 - Receptacle Module (ERM)
 - Communications Module (ECM)
 - Fascia Cover Cap (EFCC)

- Ceiling Feed condition
- Base Feed condition

2. 15" Height Vertical Cut-out for:
 - Receptacle Module (ERM)
 - Communications Module (ECM)
 - Fascia Cover Cap (EFCC)
 - Power Plus Modules (ERGMS, ERGMD, ERGMT, ERGMQ)

planning with wall-mounted lights – landscape (continued)

Electrical Box (Bypassing Functional Rails or Glass Fascias)

Electrical Feeds cannot run through a Functional Rail or a Glass Fascia and must be routed through:

- Landscape Aluminum Fascia Kit (FLFK)
- Adjacent Altos fascia without Functional Rails
- Adjacent Drywall partition

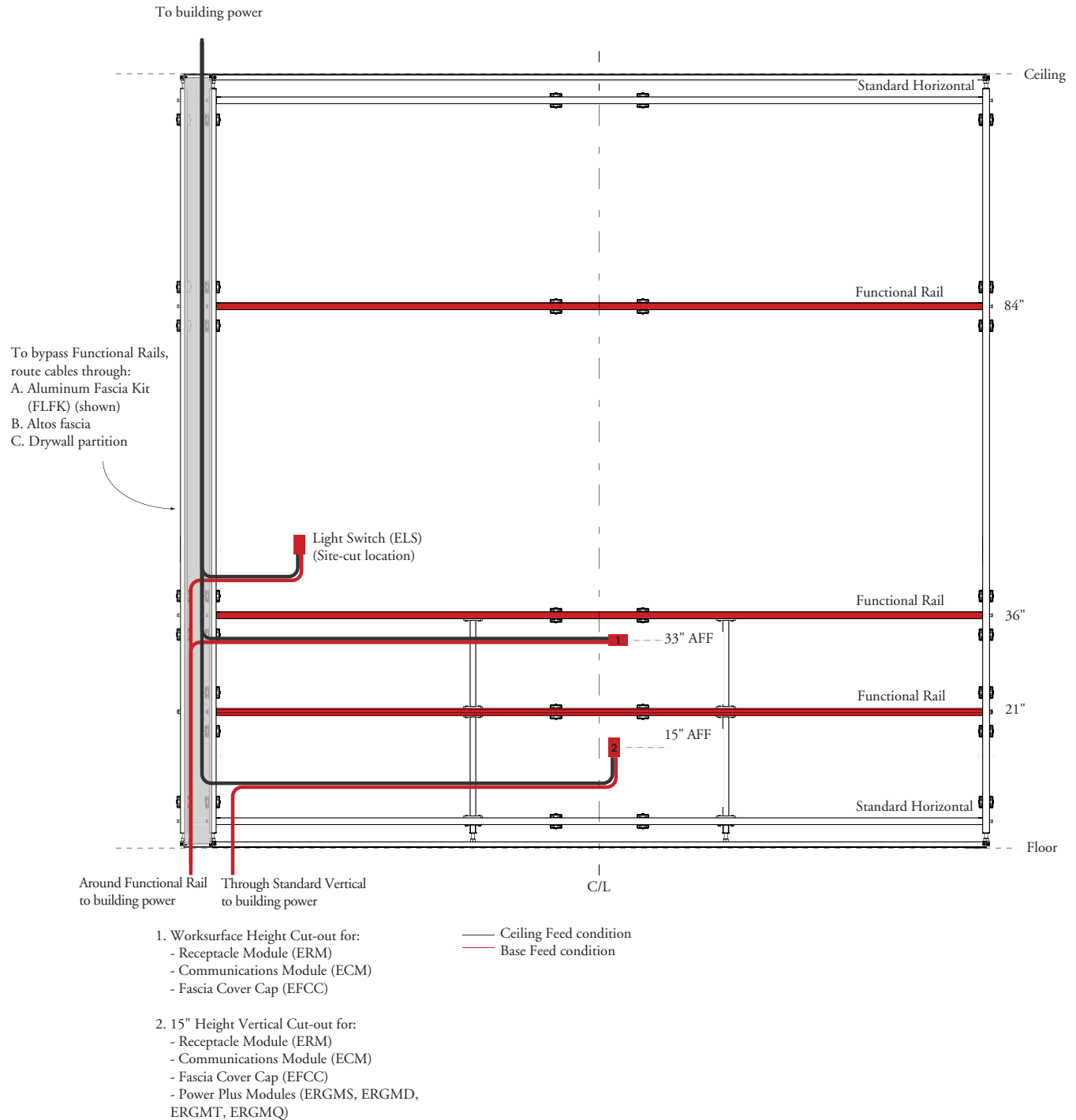

planning with wall-mounted lights – landscape (continued)

Light (Touch Switch or No Switch)

- When planning with the Landscape Wall-Mounted Light (ELWML) with either the Touch Switch or No Switch option, a Light Power Feed (ELPF) and Light Wire Management (ELWGM) must be specified as shown
- When planning with a Desk and Light together, see Desk and Light electrical routing scenarios
- Power and Communication electrics are routed independently from the Wall-Mounted Light or Desk
- Landscape Wall-Mounted Light (ELWML) with left switch and cord location is shown
- Use Installation Tool (FTTK) to run the Light cord within the vertical and horizontal reveal

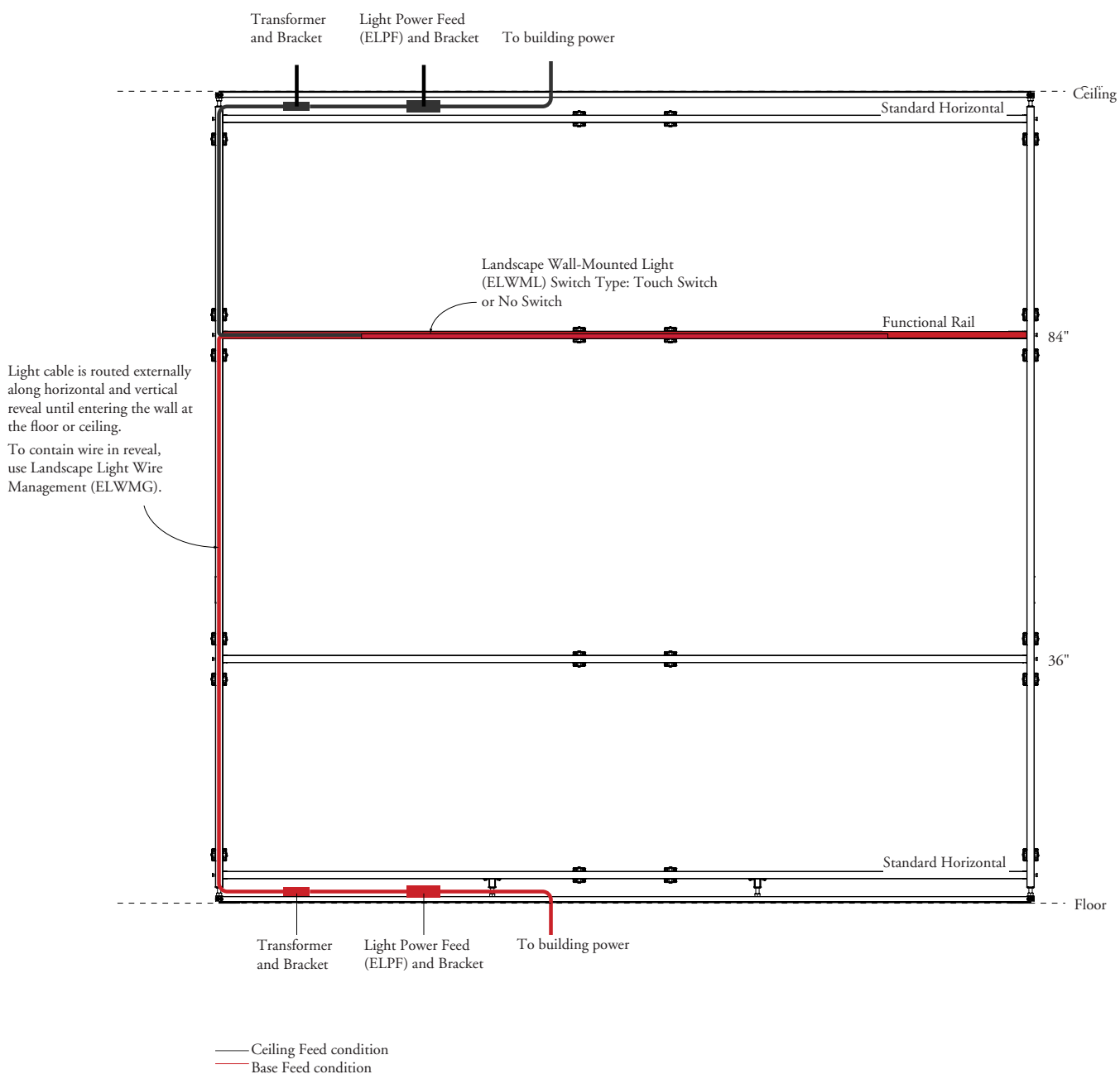

planning with wall-mounted lights – landscape (continued)

Light (Remote Switch)

- When planning with the Landscape Wall-Mounted Light (ELWML) with the Remote Switch option, Light Power Feed (ELPF), Light Wire Management (ELWGM), and Light Switch (ELS) must be specified as shown.
- When planning with a Landscape Desk and Light together, see Desk and Light electrical routing scenarios
- Remote Switch Lights must use a industry standard junction box to connect the Light Power Feed (ELPF) and Light Switch (ELS) in the floor or in the ceiling
- Power and communication electrics are routed independently from the Wall-Mounted Light or Desk
- Landscape Wall-Mounted Light (ELWML) with left switch and cord location is (shown)
- Use Installation Tool (FTTK) to run the Light cord within the vertical and horizontal reveal

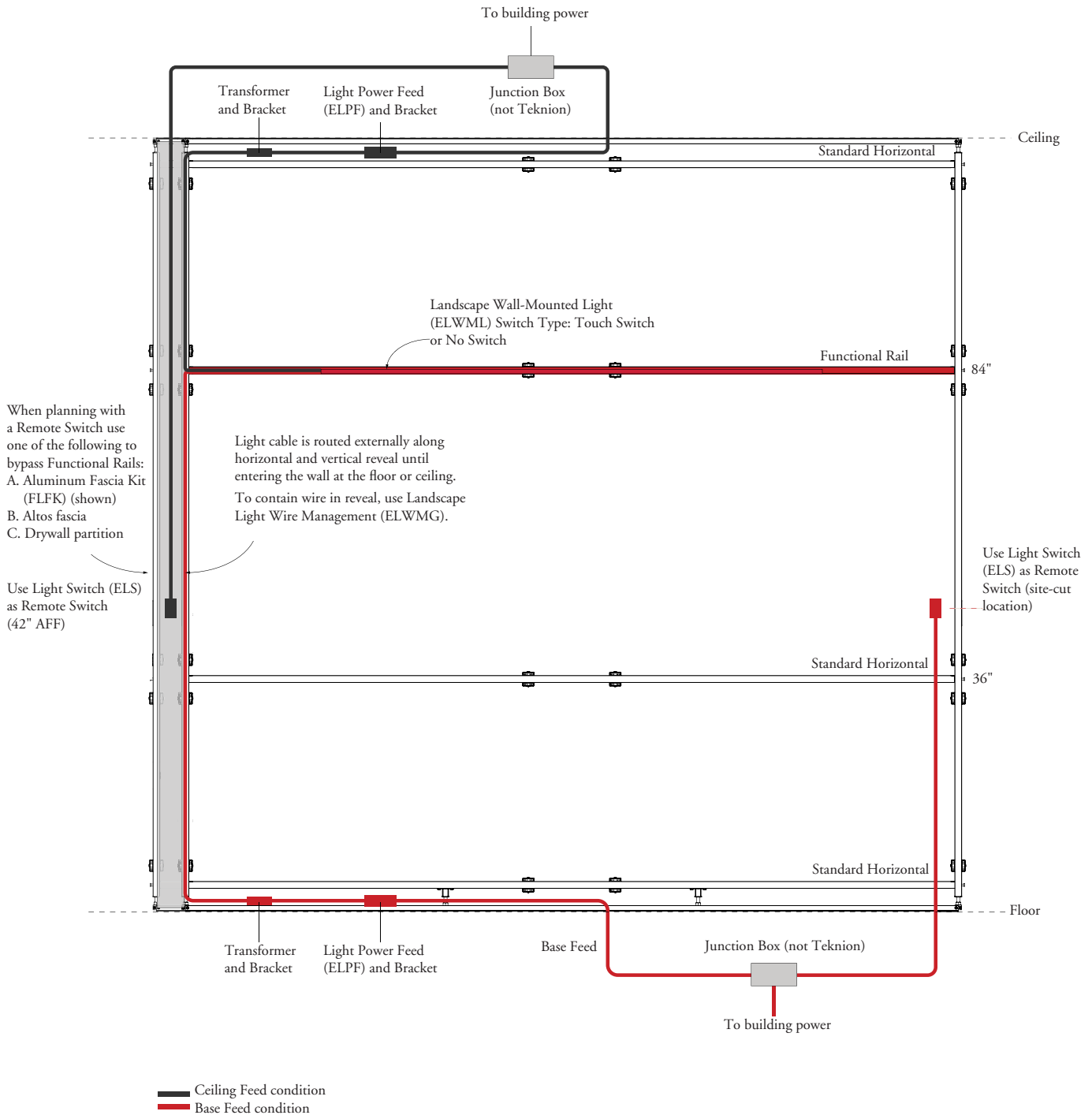

planning with wall-mounted lights – landscape (continued)

Desk with Light (Touch Switch or No Switch)

- When planning with an Landscape Desk (Fixed or Height-Adjustable) and a Wall-Mounted Light (ELWML) with the Touch Switch or No Switch option, a In-Wall Distribution Box (ELWDB) with Ceiling / Underfloor Feed (ECF) and Landscape Desk Connecting Harness (ELDH) must be specified with the desk as shown
- In-Wall distribution Box (ELWDB) with Ceiling / Underfloor Feed (ECF) and Landscape Desk Connecting Harness (ELDH) can power both the Desk and Light at the same time. Light Power Feed (ELPF) is not necessary when planning with an Landscape Desk, except for when a Remote Switch is used
- The Light cable is routed inside the wall through the desk framework. Light Wire Management (ELWGM) is not necessary when planning with a Landscape Desk
- Landscape Underdesk Fascias (WI and WM1) do not accept cut outs for power or communication electrical boxes
- Recommended location for site-cut switch:
If above Desk: 46" AFF to avoid interference with a Height-Adjustable Desk
- Landscape Desk Height-Adjustable (FLDHA) with left switch location (shown)
- Landscape Wall-Mounted Light (ELWML) with left switch and cord location is (shown)
- Power Cube (EPWRC), Power Rod (ELPR) and Rectangular Grommet (FLGR) are optional
- When planning with two desks that are back-to-back or side-by-side, use Landscape Desk Connecting Harness (ELDH)

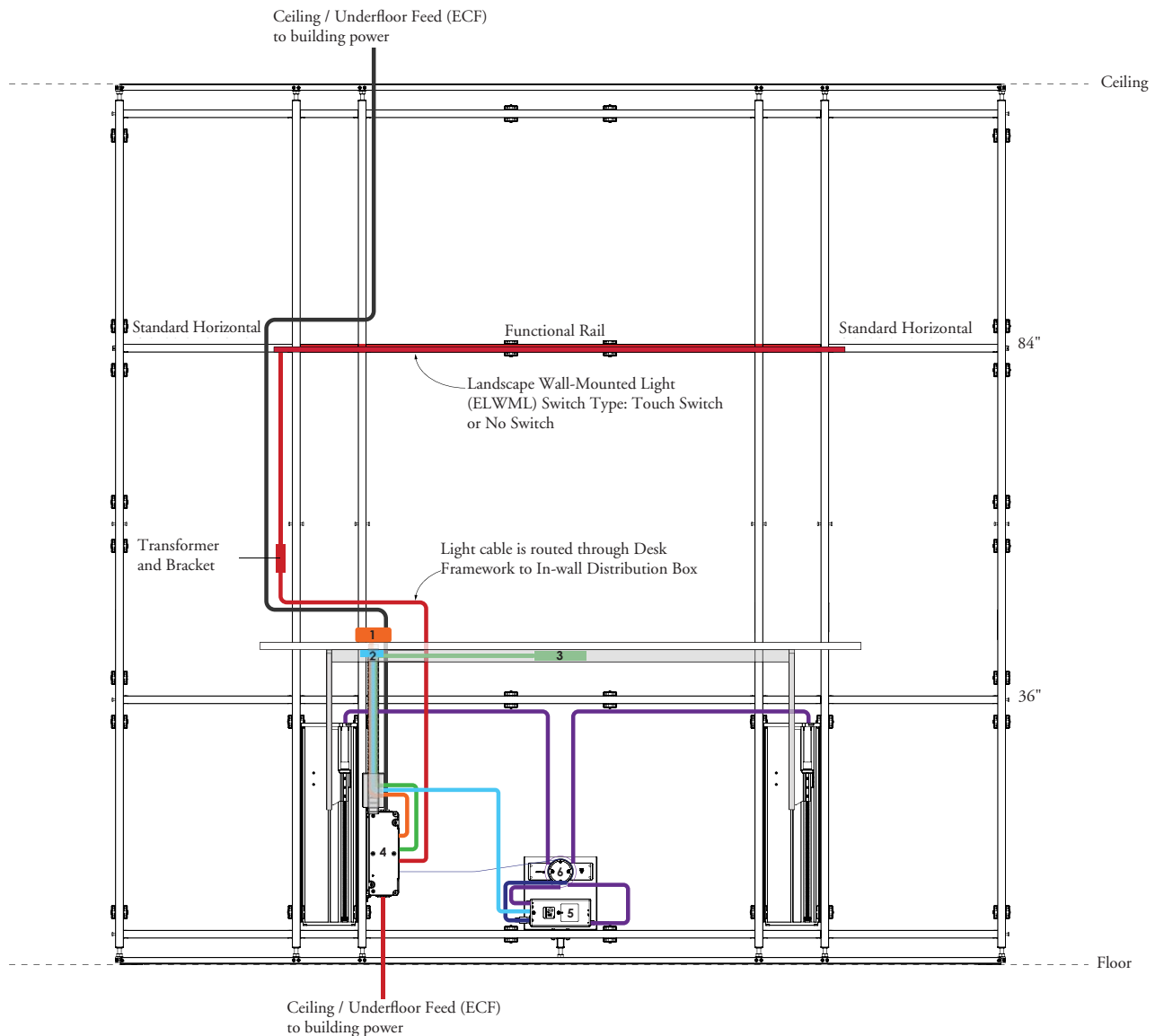

- | | |
|-------------------------------------|---------------------------|
| 1. Power Cube (EPWRC) | — Ceiling Feed condition |
| 2. Desk Switch | — Base Feed condition |
| 3. Power Rod (ELPR) | — Power Cube cable |
| 4. In-Wall Distribution Box (ELWDB) | — Desk Switch cable |
| 5. Desk Control Box | — Power Rod cable |
| 6. Wire Management Reel | — Motor Assembly cables |
| | — Control Box Power cable |

planning with wall-mounted lights – landscape (continued)

Desk with Light (Remote Switch)

- When planning with a Landscape Desk with a Wall-Mounted Light (ELWML) with the Remote Switch option, In-Wall Distribution Box (ELWDB), Ceiling / Underfloor Feed (ECF) and Landscape Desk Connecting Harness (ELDH) for the desk and Light Power Feed (ELPF) for the light must be specified as shown. It is important to note that the Light and the Desk must have independent power feeds when planning with a Remote Switch Light
- Light cable is routed inside the wall through the desk framework. Light Wire Management (ELWGM) is not necessary when planning with an Landscape Desk
- Remote Switch Lights use a industry standard junction box to connect the Light Power Feed (ELPF) and Light Switch (ELS) in the floor or in the ceiling
- Both Height-Adjustable Desk (FLDHA) or Fixed Desk (FLDFX) can be used
- Landscape Underdesk Fascias (W1 and WM1) do not accept cut outs for power and communication electrical boxes
- Recommended location for site-cut switch:
If above Desk: 46" AFF to avoid interference with Height-Adjustable Desk
- Landscape Desk Height-Adjustable(FLDHA) with left switch location (shown)
- Wall-Mounted Light (ELWML) with left switch and cord location is (shown)
- Power Cube (EPWRC), Power Rod (ELPR) and Rectangular Grommet (FLGR) are optional
- When planning with two desks that are back-to-back or side-by-side, use Landscape Desk Connecting Harness (ELDH)

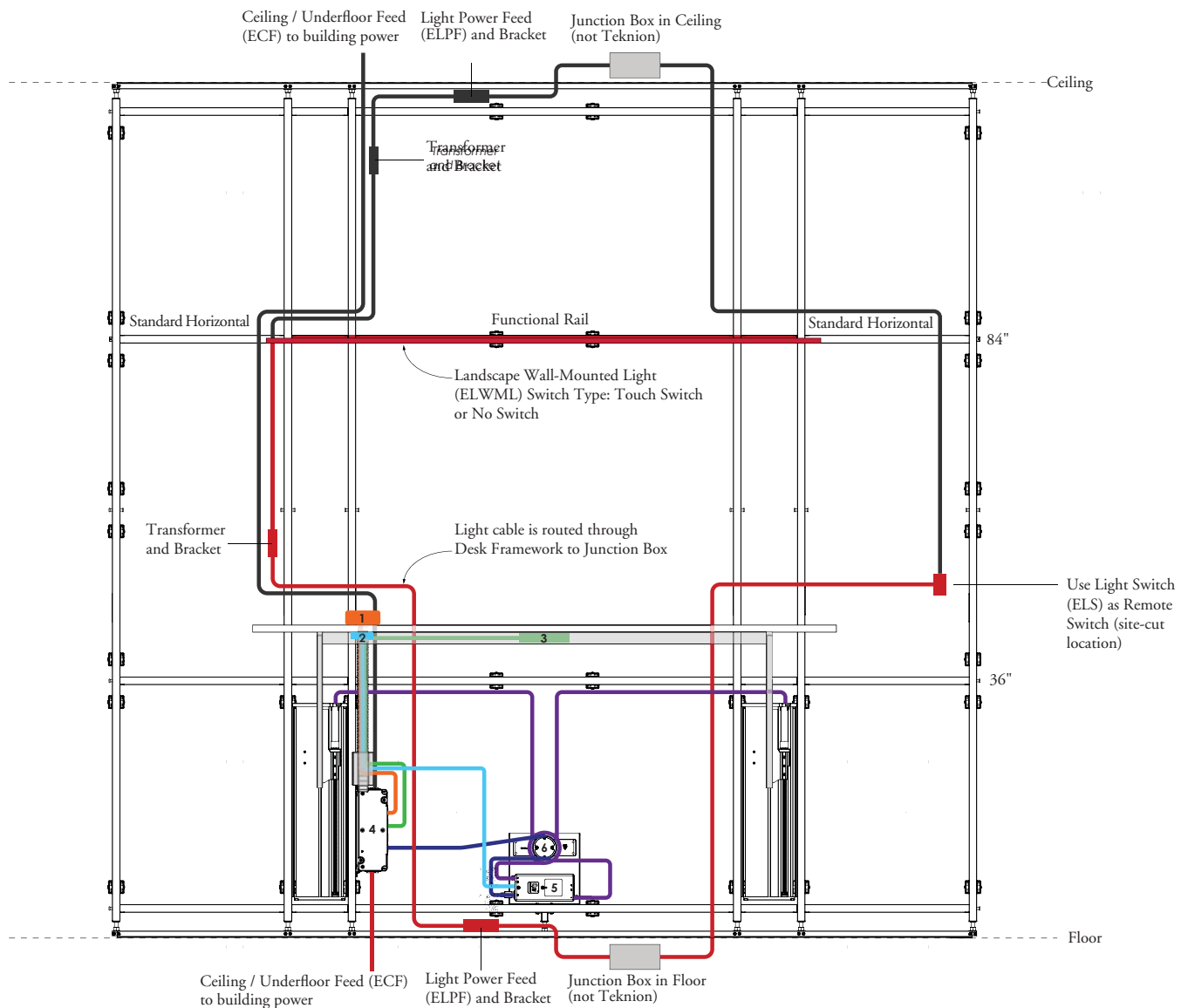

- | | |
|-------------------------------------|---------------------------|
| 1. Power Cube (EPWRC) | — Ceiling Feed condition |
| 2. Desk Switch | — Base Feed condition |
| 3. Power Rod (ELPR) | — Power Cube cable |
| 4. In-Wall Distribution Box (ELWDB) | — Desk Switch cable |
| 5. Desk Control Box | — Power Rod cable |
| 6. Wire Management Reel | — Motor Assembly cables |
| | — Control Box Power cable |

electrics & communications overview – landscape

There are five methods of supplying power and communications in Altos Landscape, each method functions differently. The following chart will help you select the appropriate solution.

	Field-supplied Electrics	Hardwire Electrics	Power Plus Communications Electrics
application	<ul style="list-style-type: none"> • Uses industry standard receptacles commonly used in drywall applications • Contractor provides all electrical components – only the Fascias are specified with cut outs • Client customized 	<ul style="list-style-type: none"> • Used in single office applications • Individual feed to each receptacle 	<ul style="list-style-type: none"> • Used in single office applications • Individual feed to each box with disconnect in ceiling • Each box can hold one data plus one to three Duplex
benefits	<ul style="list-style-type: none"> • Contractor provides all electrical components • Fascia cut outs accept industry standard duplex or decora style receptacles 	<ul style="list-style-type: none"> • Industry standard receptacle module pre-wired with 20' – 0" cable • Includes standard electrical box, decora receptacle and faceplate • Standard and isolated circuits • 120 volt; 15 and 20 amp options • Communications module accepts modular furniture or decora strap faceplates • Voice/data jacks and cabling not included 	<ul style="list-style-type: none"> • 120 volt; 15 amp and 20 amp options • Communication opening accepts modular furniture faceplates • One faceplate is used for the entire box
features	<ul style="list-style-type: none"> • Compatible with standard electrical wiring systems 	<ul style="list-style-type: none"> • Compatible with standard electrical wiring systems • Each receptacle fed individually • Does not route power between receptacles 	<ul style="list-style-type: none"> • Available in many wire systems • Compatible with standard electrical wiring systems • Does not route power between receptacles • Single box for power and data • Easy to disconnect for relocation
wire systems	<ul style="list-style-type: none"> • Standard Circuit • Isolated Circuit 	<ul style="list-style-type: none"> • Standard Circuit • Isolated Circuit 	<ul style="list-style-type: none"> • 4B • 5D • 6G • 7G • 8T • 8K
electrical components available		<ul style="list-style-type: none"> • Receptacle Module (ERM) • Communications Module (ECM) • Light Switch (ELS) • Fascia Cover Cap (EFCC) 	<ul style="list-style-type: none"> • Power Plus Communications Module – Single (ERGMS) • Power Plus Communications Module – Double (ERGMD) • Power Plus Communications Module – Triple (ERGMT) • Power Plus Communications Module – Quad (ERGMQ) • Power Plus Communications Module Starter Cable (ERSC)

electrics & communications overview – landscape (continued)

	Landscape Collection Support Electrics	Altos Desk Power Accessories
application	<ul style="list-style-type: none"> Used to support internal electrical requirements for Altos Desk and Altos Light * For more details please refer to Landscape wall-mounted light basics and Landscape Desk Basics 	<ul style="list-style-type: none"> Electrics accessories for on the Altos Desk * For more details please refer to Desk Accessory Basics section
benefits	<ul style="list-style-type: none"> Powers Altos Desk and Light with integrated cables and power feed contained within the wall 	<ul style="list-style-type: none"> User accessible accessories available on the Altos Desk for power and data requirements
features	<ul style="list-style-type: none"> Available in many wire systems Comparable with standard electrical wiring systems Easy to disconnect for relocation 	<ul style="list-style-type: none"> Dual or Quad power cube available with power, USB or data options Power Rod available with four power simplexes
wire systems	<ul style="list-style-type: none"> • 4B • 5D • 6G • 7G • 8T • 8K 	<ul style="list-style-type: none"> Plugs into In-Wall Distribution Box (ELWDB)
electrical components available	<ul style="list-style-type: none"> ECF * Not necessary with Light Power Feed (single circuit) Light Power Feed (ELPF) In-Wall Distribution Box (ELWDB) Landscape Desk Connecting Hardness (ELDH) Landscape Light Wire Management (ELWMG) 	<ul style="list-style-type: none"> Power Cube (EPWRC) Power Rod (ELPR) Rectangular Grommet (FLGR)

power accessories

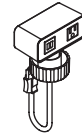

Power Cube (EPWRC)

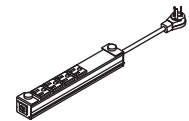

Power Rod (ELPR)



Rectangular Grommet (FLGR)

hardwire electric & communications basics – landscape

Hardwire components consist of receptacle modules, communications modules and power distribution boxes.

- Connection to building supply must be done by a qualified electrician
- Fascia cut outs may not accept client-supplied standard electric/data boxes, receptacles and faceplates, the factory cut outs match factory electrics
- One size cut out fits both receptacle and communications modules. Any combination of Receptacles or Communications Modules are possible

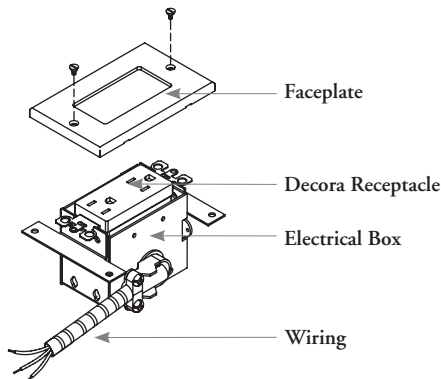
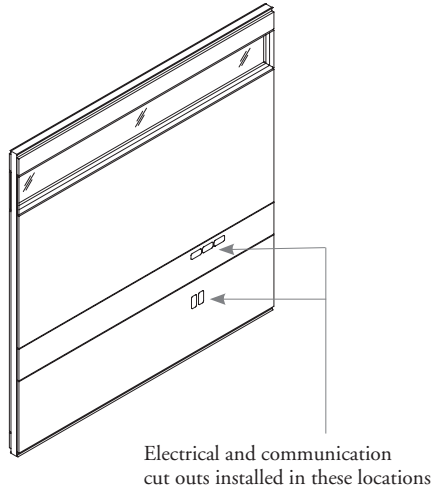

Receptacle Module (ERM)

- Provides access to electrical power and can be installed at all Fascia cut outs located at 15" height and worksurface height
- Available in Standard or Isolated Ground
- Pre-wired with 20'-0" cable
- Altos receptacles are standard 120-volt with a choice of 15 or 20 amps
- Comes ready for installation and includes a standard electrical/data box, decora receptacle and faceplate

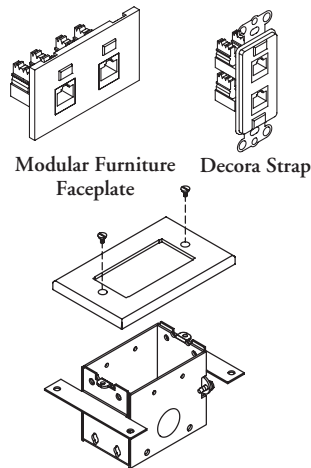

Communications Module (ECM)

- Voice and data are brought to the workspace via the Communications Module and can be used in all Fascia cut outs located at 15" high and worksurface height
- Accepts modular furniture or decora strap faceplates (not supplied by Teknion)
- Jacks/faceplates and cabling not included
- Can be specified to accept the pictured two faceplates
- Can be specified to accept twisted pair, fiber optic or coaxial cable (supplied by others)

Combining Receptacle and Communication Modules

- One size cut out fits both receptacle and Communications Modules
- Any combination of Receptacles or Communications Module are possible

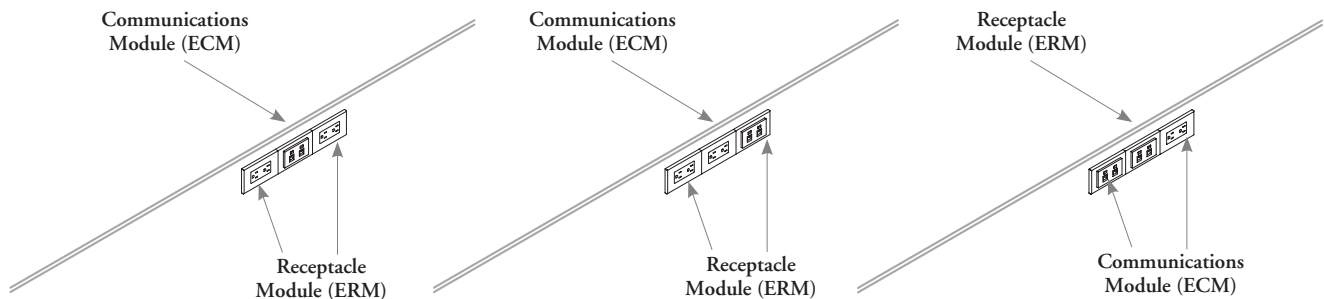

planning with hardwire electrical & communications – landscape

The following should be considered when planning with hardwire electrics and communications.

Electrical and communication cables are fed from the ceiling or from access floors through cut outs in the Ceiling or Base Channels to Receptacle and Communications Modules.

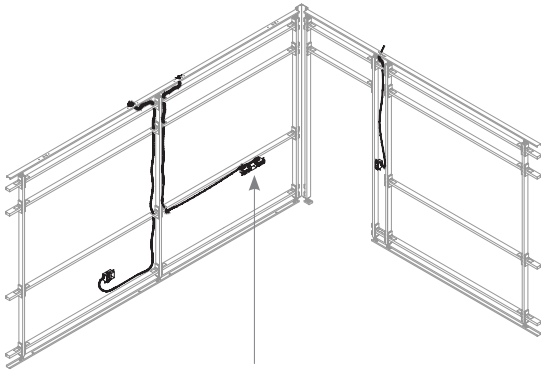

Receptacle Modules are pre-wired with a 20'-0" cable and must be connected to building supply by a qualified electrician

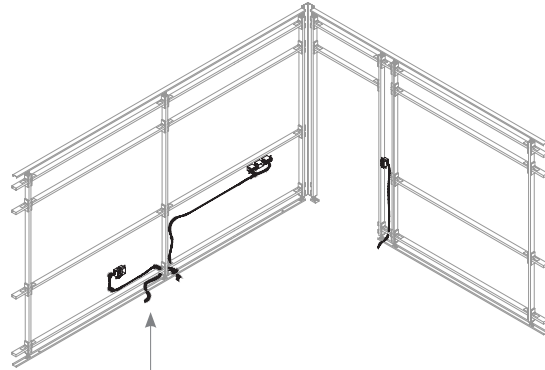

- Communications Modules are not pre-wired
- All cables must be supplied by the cable contractor

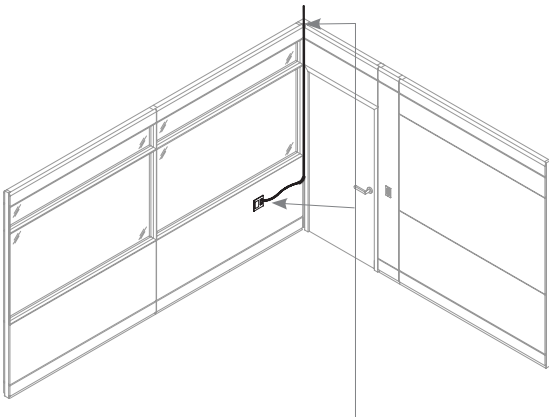

Ceiling feed must be routed vertically through corner connections when planning with clerestories or glazed Fascias and horizontally to Receptacle or Communications Modules

Hardwired Circuit Diagram

Standard Circuit

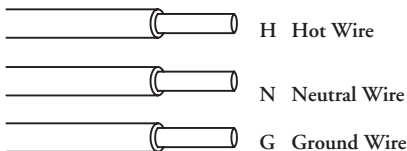

Isolated Ground Circuit

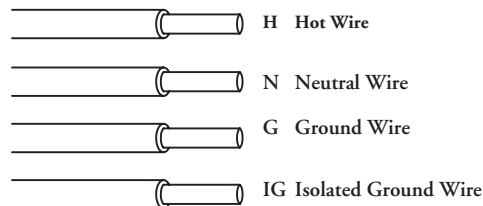

Altos Receptacle Modules (ERM) and Light Switches (ELS) are compatible with standard electrical wiring systems used in drywall building applications. These consist of three wires (one circuit) for standard circuits and four wires for isolated ground circuits. This simplified approach to power eliminates the need for coordinating various circuit configurations. Receptacles can be specified as standard or isolated ground

power plus communications module electrics basics – landscape

Power plus communication modules allow office spaces to be powered directly from Altos walls.

- All components must be specified from same wire system – systems available – 4B, 5D, 6G, 7G, 8T and 8K
- Power from a single building supply may be routed to multiple offices
- Back-to-back installation of electrics and communications is possible by off-set mounting on the Fascia

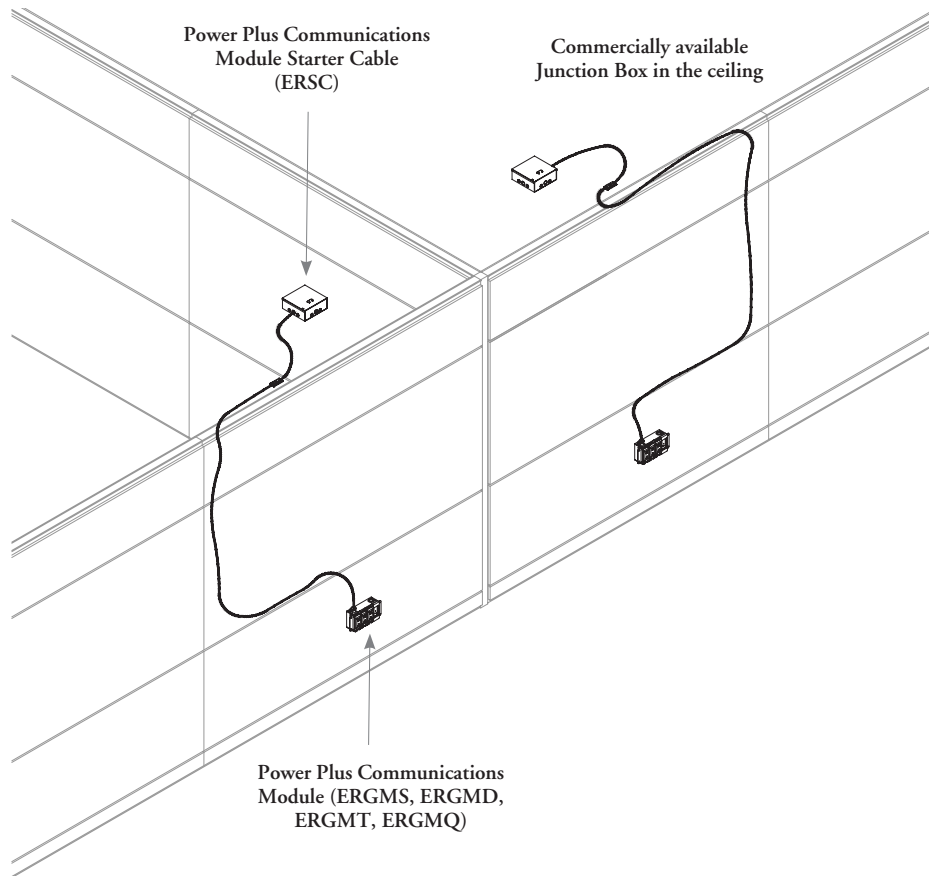

Power Plus Communications Module Starter Cable (ERSC)

- Is used at every location that Power Plus Communications Modules are used to connect the electrics to the ceiling power
- Available 12" long and in 4B, 5D, 6G, 7G, 8T and 8K wiring systems

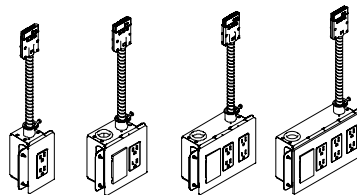

Power Plus Communications Module (ERGMS, ERGMD, ERGMT, ERGMQ)

- Provides data and 1 - 3 duplexes on one faceplate for single office applications
- Each feed routes directly to the Power Plus Communications Module
- Cable lengths are available 20' and 30' long
- Available 120 volt and 15 amp or 20 amp
- Available in Single (ERGMS), Double (ERGMD), Triple (ERGMT) and Quad (ERGMQ) options
- Faceplates are available in E1 Black or E2 White
- Solid and Fabric Wrapped Fascias are available with cut outs to match each Power Plus Communications Module types. See the Fascias section for more details

planning with power plus communications modules – landscape

The following should be considered when planning with power plus communications modules.

underfloor and ceiling feeds

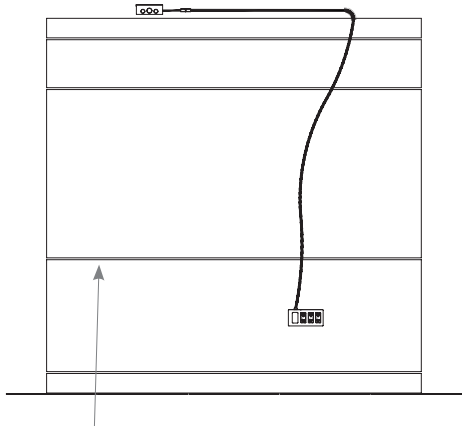

Functional Rail

The Power Plus Communications Module Starter Cable (ERSC) **cannot** be routed through Fascia packages that include glazed Fascias or Functional Rails.

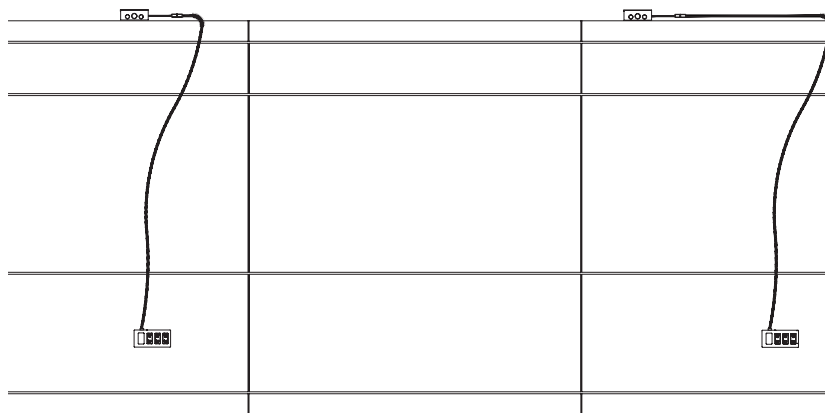

- Each Power Plus Communications Module is individually powered
- The cable is routed directly to the ceiling with a Power Plus Communications Module Starter Cable (ERSC)

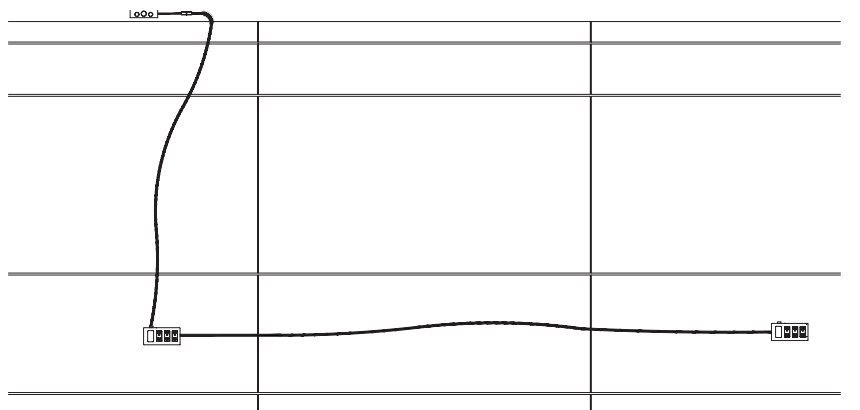

The Power Plus Communications Modules are **not** connected with harnesses



power plus communications module compatibility chart – landscape

All Power Plus Communications Modular electrics must be specified according to the wire system in use. The following chart identifies compatibility between Altos Power Plus Communications Modular electrics.

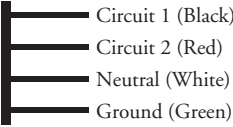
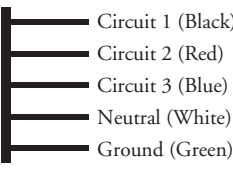
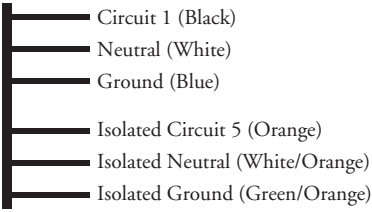
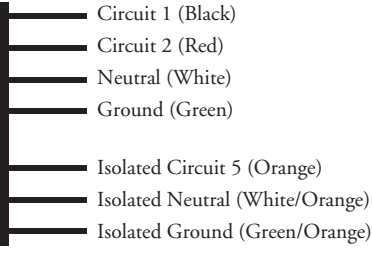
Wire System	Code	No. of Regular Circuits	No. of Isolated Circuits
<p>4-wire</p> 	4B	2	0
<p>5-wire</p> 	5D	3	0
<p>6G-wire, Isolated Ground</p> 	6G	1	1
<p>7-wire, Isolated Ground</p> 	7G	2	1

power plus communications module compatibility chart – landscape (continued)

All Power Plus Communications Modular electrics must be specified according to the wire system in use. The following chart identifies compatibility between Altos Power Plus Communications Modular electrics.

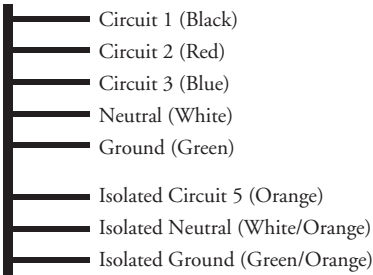
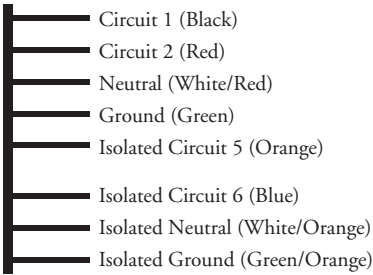
Wire System	Code	No. of Regular Circuits	No. of Isolated Circuits
8-wire, Isolated Ground 	8T	3	1
8-wire, Dual Isolated 	8K	2	2

specifying altos electrics & communications – landscape

The following steps should be followed when specifying electrics.

- The inside and outside elevations of one wall module can both be installed with Receptacle and/or Communications Modules
- Back-to-back installation of electrics and communications is possible due to offset mounting on Fascias

specifying method

step 1

Determine Fascia configuration and level of cut out

When power and/or communications is required, Altos Fascias must be specified with corresponding out-outs. Non-powered Fascias can be retrofitted with electrics and communications by ordering a single new Fascia with appropriate cut out(s) and required electrical components

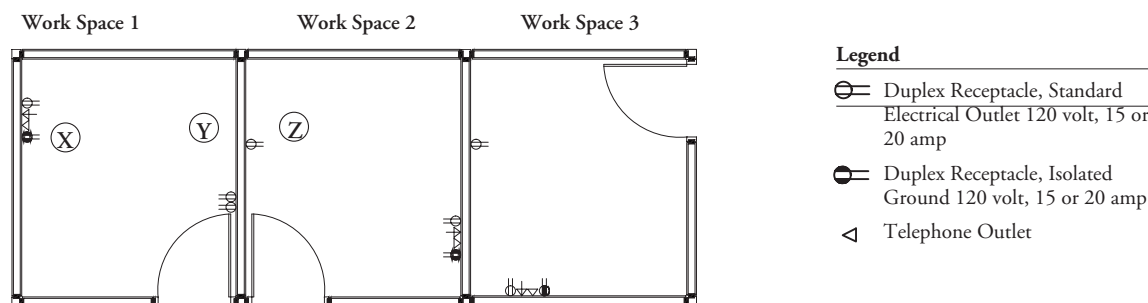

- All cut outs are located right of center-line on the front of the Fascia so electrics and communications can be specified on both inner and outer elevations of the same wall module
- At worksurface height, cut outs are always oriented horizontally. At 15" height, cut outs are always oriented vertically

step 2

Order appropriate Power and Communications electrical boxes. The total number should match the total number of cut outs specified on Fascias.

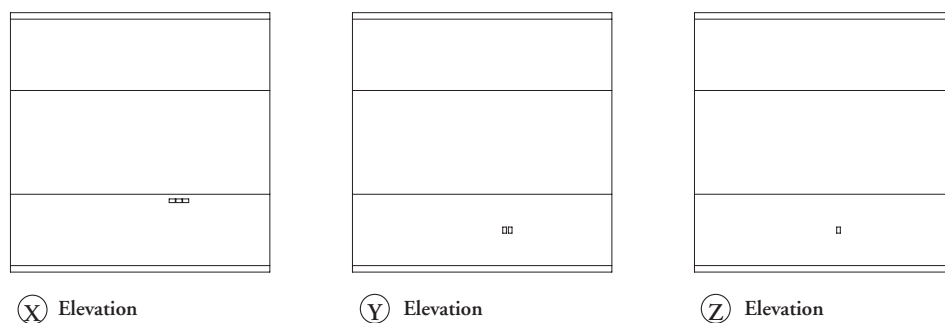

fascia cut out locations

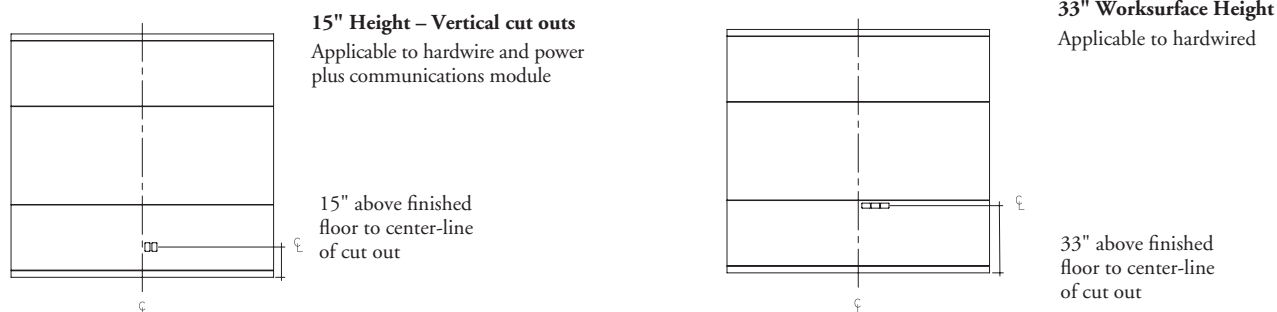

Fascia cut outs are required for accessing power and communications. Cut out locations vary depending on the application type.







power/communication fascia cut outs – landscape

The number of cut outs for hardwire and power plus communications module electrics depends on Fascia width. The chart below outlines the number of openings available by size in Altos Landscape.

- Power and communication cut outs are available on Landscape Solid and Fabric Wrapped Fascias only
- Fascia Cover Caps (EFCC) can be ordered to cover unused hardwire cut outs

Cut Out Height	Fascia Widths 22" - 31" & 72-1/8" - 90"	31-1/8" - 40" & 90-1/8" -120"	40-1/8" - 72"
Worksurface – Hardwire	 One cut out - FLW1, FLWM1, FLTW1, FLRW1, FLRWM1, FLRTW1 For use with ERM or ECM	 Two cut outs - FLW1, FLWM1, FLTW1, FLRW1, FLRWM1, FLRTW1 For any combination of ERM and ECM	 Three cut outs - FLW1, FLWM1, FLTW1, FLRW1, FLRWM1, FLRTW1 For any combination of ERM and ECM

Cut Out Height	Fascia Widths 12" - 120"	12" - 120"
15" Height – Hardwire	 One cut out - FLW1, FLWM1, FLBW1, FLBWM1, FLRW1, FLRWM1, FLRBW1, FLRBWM1 For use with ERM or ECM	 Two cut outs - FLW1, FLWM1, FLBW1, FLBWM1, FLRW1, FLRWM1, FLRBW1, FLRBWM1 For any combination of ERM and ECM

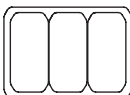
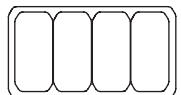
Cut Out Height	Fascia Widths 13" - 120"	17" - 120"	21" - 120"	25" - 120"
15" Height Power Plus Communications Module	 Single (S) – ERGS	 Single (S) – ERGS Double (D) – ERGD	 Single (S) – ERGS Double (D) – ERGD Triple (T) – ERGT	 Single (S) – ERGS Double (D) – ERGD Triple (T) – ERGT Quad (Q) – ERGQ

determining electric & communications requirements – landscape

The following steps should be followed when determining electrical requirements.

- The distribution of power is the responsibility of the electrical contractor
- The number of power outlets and voice/data jacks per workspace should be determined by end-user requirements
- Voice/data jack/faceplates are supplied by the cable contractor
- Check amperage of specific equipment that will be used. Amperage used below are for sample purposes only

step 1:

List all office equipment and lighting requirements for each work space with appropriate amperage loads. Calculate total amperage required for each work space. Altos receptacles are standard 120-volt, 15 or 20A. 220-volt equipment should be assigned to an alternative electrical distribution system.

Work Space #	Requirement	Amps	Module Required	Type of Circuit	Circuit
1	Personal Computer	4.00			
	Desk Lamp	1.00			
	One Convenience Outlet	4.00			
	Total Amps #1	9 amps			
2	Personal Computer	4.00			
	Desk Lamp	1.00			
	One Convenience Outlet	4.00			
	Total Amps #2	9 amps			
3	Personal Computer	4.00			
	Laser Printer	7.00			
	Desk Lamp x 2	2.00			
	Total Amps #3	13 amps			
	Total Amperage	31 amps			

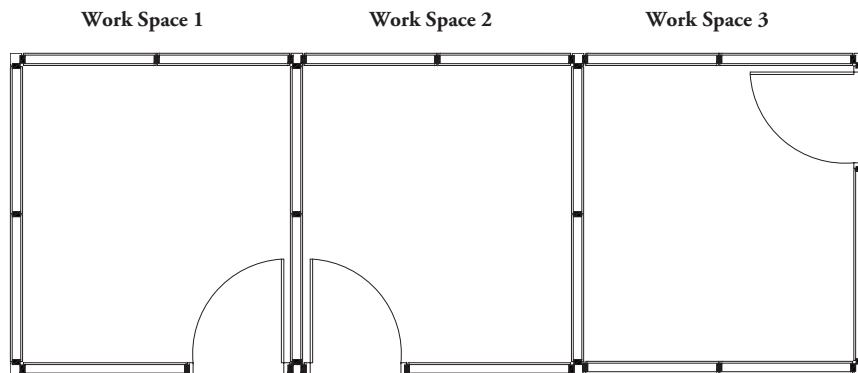

determining electrics & communications requirements – landscape (continued)

step 2:

Determine the number and location of Power and Communication electrical boxes needed in each workspace. Some equipment (e.g. computers) may require an isolated circuit and this should be specified at this stage.

Work Space #	Requirement	Amps	Module Required	Type of Circuit	Circuit
1	Personal Computer	4.00	Duplex Receptacle	Isolated Ground or Standard, 120 V, 15 amp	
	Desk Lamp	1.00	Duplex Receptacle	Standard, 120 V, 15 amp	
	One Convenience Outlet	4.00	Duplex Receptacle	Standard, 120 V, 15 amp	
	Total Amps #1	9 amps			
2	Personal Computer	4.00	Duplex Receptacle	Isolated Ground or Standard, 120 V, 15 amp	
	Desk Lamp	1.00	Duplex Receptacle	Standard, 120 V, 15 amp	
	One Convenience Outlet	4.00	Duplex Receptacle	Standard, 120 V, 15 amp	
	Total Amps #2	9 amps			
3	Personal Computer	4.00	Duplex Receptacle	Isolated Ground or Standard, 120 V, 15 amp	
	Laser Printer	7.00	Duplex Receptacle	Standard, 120 V, 15 amp	
	Desk Lamp x 2	2.00	Duplex Receptacle	Standard, 120 V, 15 amp	
	Total Amps #3	13 amps			
	Total Amperage	31 amps			

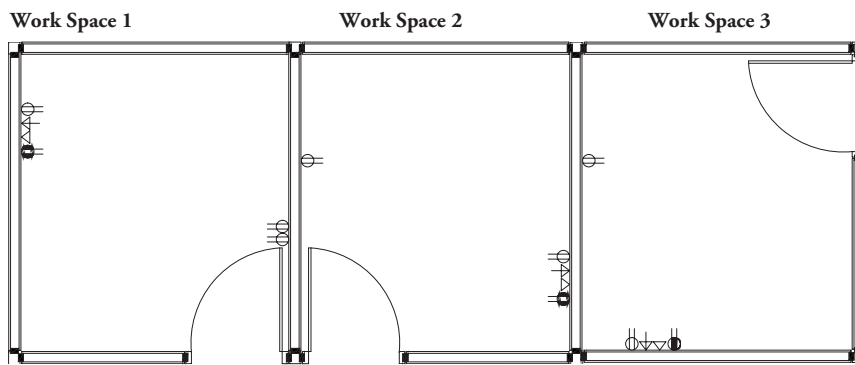

Legend

- ⊖ Duplex Receptacle, Standard Electrical Outlet 120 volt, 15 or 20 amp
- ⊖ Duplex Receptacle, Isolated Ground 120 volt, 15 or 20 amp
- ◁ Telephone Outlet
- ◁ Communications Outlet with Twisted Pair Signal Cable

determining electrics & communications requirements – landscape (continued)

step 3:

Balance the electrical load by assigning equipment to specific circuits. It is necessary to know the building's circuit capacity to do this. Also check local code requirements so that the maximum number of receptacles per circuit is not exceeded.

Work Space #	Requirement	Amps	Module Required	Type of Circuit	Circuit
1	Personal Computer	4.00	Duplex Receptacle	Isolated Ground or Standard, 120 V, 15 amp	A
	Desk Lamp	1.00	Duplex Receptacle	Standard, 120 V, 15 amp	B
	One Convenience Outlet	4.00	Duplex Receptacle	Standard, 120 V, 15 amp	B
	Total Amps #1	9 amps			
2	Personal Computer	4.00	Duplex Receptacle	Isolated Ground or Standard, 120 V, 15 amp	A
	Desk Lamp	1.00	Duplex Receptacle	Standard, 120 V, 15 amp	C
	One Convenience Outlet	4.00	Duplex Receptacle	Standard, 120 V, 15 amp	C
	Total Amps #2	9 amps			
3	Personal Computer	4.00	Duplex Receptacle	Isolated Ground or Standard, 120 V, 15 amp	A
	Laser Printer	7.00	Duplex Receptacle	Standard, 120 V, 15 amp	D
	Desk Lamp x 2	2.00	Duplex Receptacle	Standard, 120 V, 15 amp	D
	Total Amps #3	13 amps			
	Total Amperage	31 amps			

Altos receptacles are decora-style and are rated for 15 or 20 amps. For continuous loads, de-rate load capacity of the circuit to 80% of rating or whats required by local codes. It is advised to consult with local electrician.

step 4:

Determine the number of voice and data jacks required for each workspace. Communication jacks, faceplates and cables are supplied by the cabling contractor.

step 5:

Translate electrics and communications requirements into appropriate Altos product.

landscape – collection &
accessories

landscape – collection & accessories

COLLECTION OVERVIEW – LANDSCAPE	300
SHELF BASICS – LANDSCAPE.	301
PLANNING WITH SHELVES – LANDSCAPE	302
DESK BASICS – LANDSCAPE	304
PLANNING WITH DESKS – LANDSCAPE	305
DESK ACCESSORY OVERVIEW – LANDSCAPE	314
DESK FINISHES – LANDSCAPE.	315
WALL-MOUNTED CABINET BASICS – LANDSCAPE	316
PLANNING ELEVATED CABINETS – LANDSCAPE.	317

collection overview – landscape

The Landscape Collection consists of wall-integrated shelving, lighting, storage and height adjustable and fixed desks. The Landscape Collection can be mounted off-module, allowing for greater planning flexibility and maximizing floor space.



1 Landscape Wall-Mounted Light (ELWML)

- Provides task or ambient lighting applications above a desk, whiteboard, or along a storefront corridor

2 Power Cube (EPWRC)

- Provides user accessible Power, USB and Data to the Landscape Desk

3 Landscape Desk Fixed (FLDFX), Height-Adjustable (FLDHA)

- Landscape desks provide a Wall-Mounted desking solution to keep overall footprint of the room to a minimum
- Ideal enclave or office spaces
- Fixed or Height-Adjustable options available

4 Landscape Wall-Mounted Cabinet Open (FLWCO), Sliding Door (FLWCS)

- Landscape Wall-Mounted cabinets provide a semi-permanent or temporary storage application
- Available as an open cubby or with a sliding door

5 Landscape Fitted Seat Cushion (FLC)

- Provides temporary seating solution on Wall-Mounted Cabinet
- Available in upholstery fabrics

shelf basics – landscape

Landscape shelves are available in various materials and are ideal for personal or occasional storage. They can be mounted to the 36" and 60" horizontal datum.



Landscape Solid shelf (FLSS) (Shown)

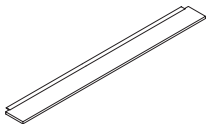

Landscape Shelf Solid (FLSS)

- Ideal for larger item storage and accommodates letter-sized paper
- 9" deep x 48-1/8" - 96" wide in 1/8" increments
- 1" thick with integrated connecting beam
- Available with flat edge
- Finishes:
 - Shelf: Foundation Lamine, Flintwood
 - Connecting Beam: Paint: Foundation, Mica

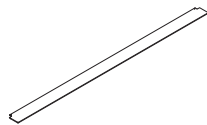

Landscape Shelf Aluminum (FLSA)

- 4" deep x 48-1/8" - 120" wide in 1/8" increments
- 7mm thick extruded profile
- Finishes:
 - Paint: Foundation, Accent, Mica

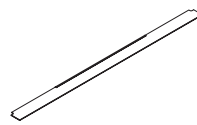

Landscape Shelf Glass (FLSG)

- 4" deep x 48-1/8" - 96" wide in 1/8" increments
- 6mm tempered glass

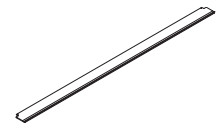

Landscape Shelf Whiteboard (FLTW)

- Used below a backpainted glass fascia or wall-mounted monitor
- 4" deep x 48-1/8" - 120" wide in 1/8" increments
- 7mm thick extruded profile
- Finishes:
 - Paint: Foundation, Accent, Mica

planning with shelves – landscape

The following should be considered when planning with Landscape shelves.

horizontal placement

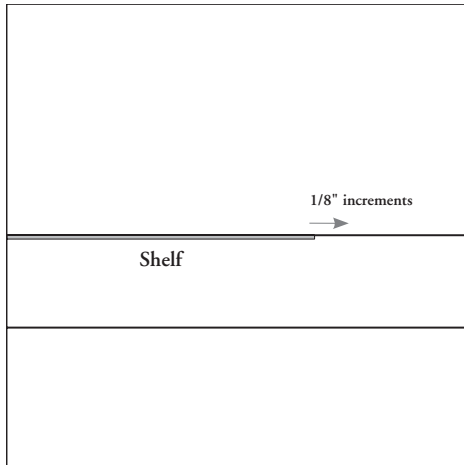

- The shelf can be installed within the Functional Rail in 1/8" increments along the horizontal reveal
- When fully justified to the left or right on the wall the shelf will align to the edge of the fascia

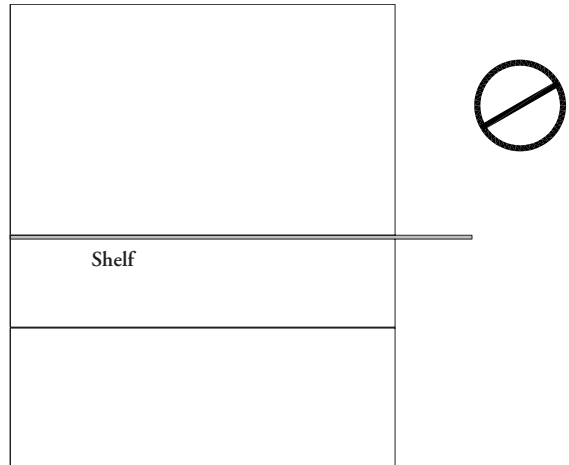

- A Shelf's nominal width must be equal to or less than nominal width of the fascia

above a desk

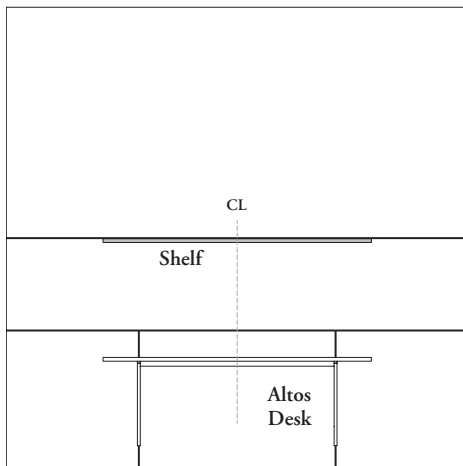

- When planning with an Altos desk the shelf must align with the desk's centerline and be the same nominal width as the desk

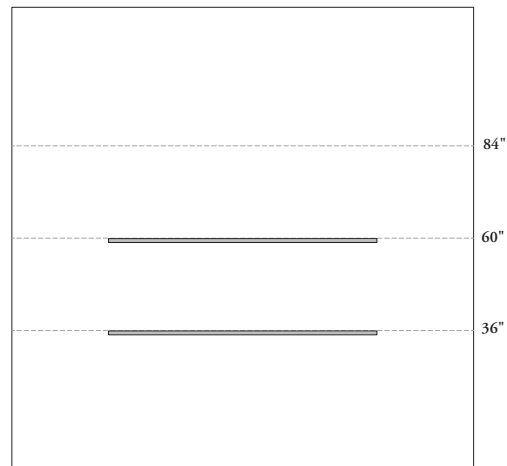

- Wood, Aluminum, Glass and Whiteboard Tray shelves are available on 36" and 60" horizontal reveals only
- Multiple Shelves can be installed on each reveal

planning with shelves – landscape (continued)

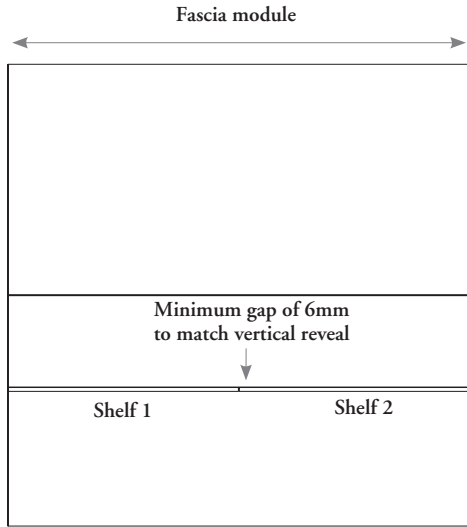

When planning two shelves side by side, it is recommended to specify shelf widths so that there is a spacing of 6mm between them to match the vertical fascia reveal.

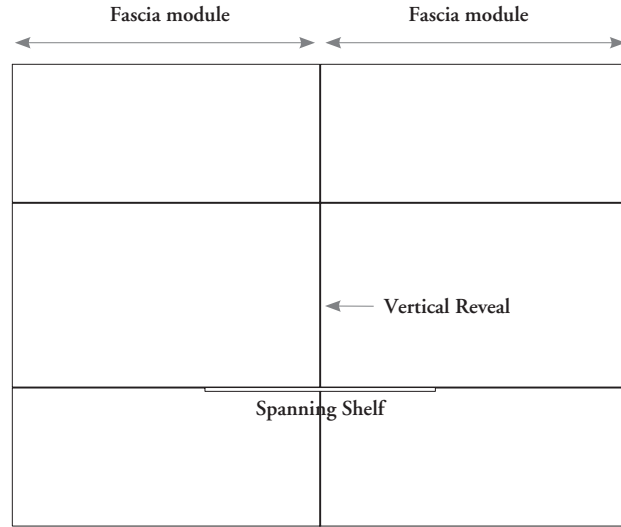

The shelves **cannot** span across a vertical reveal.

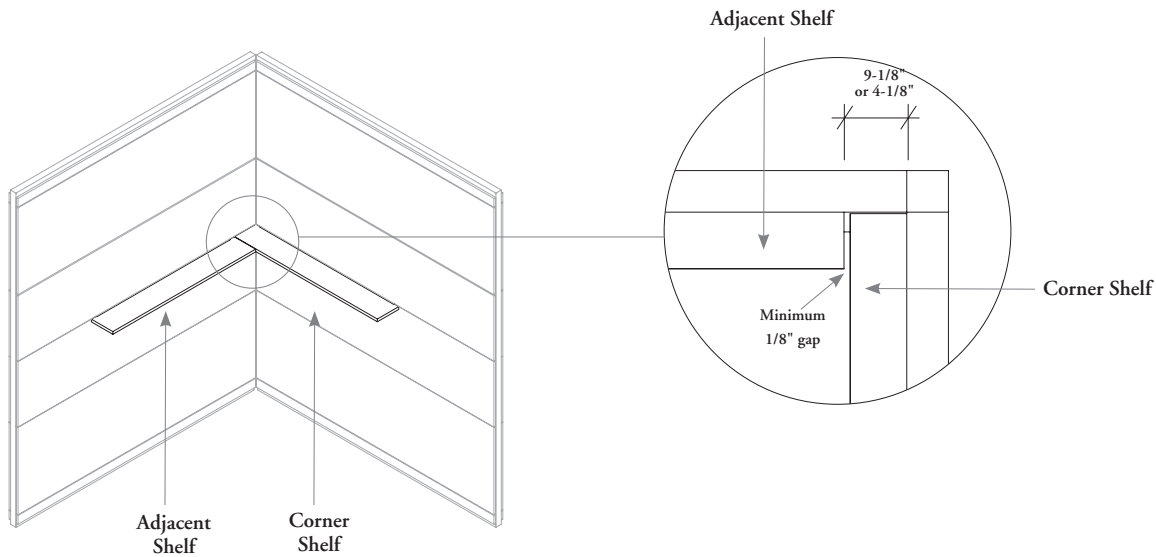

When planning two shelves in a corner, the adjacent shelf must be specified to be a minimum of 4-1/8" or 9-1/8" from the edge of the fascia to accommodate the shelf depth as well as a 1/8" gap.

- Aluminum, Glass and Whiteboard shelves: 4-1/8"
- Solid shelf: 9-1/8"

desk basics – landscape

Landscape desks provide a wall-mounted desking solution that maximizes usable space in an environment and hides unnecessary cables.

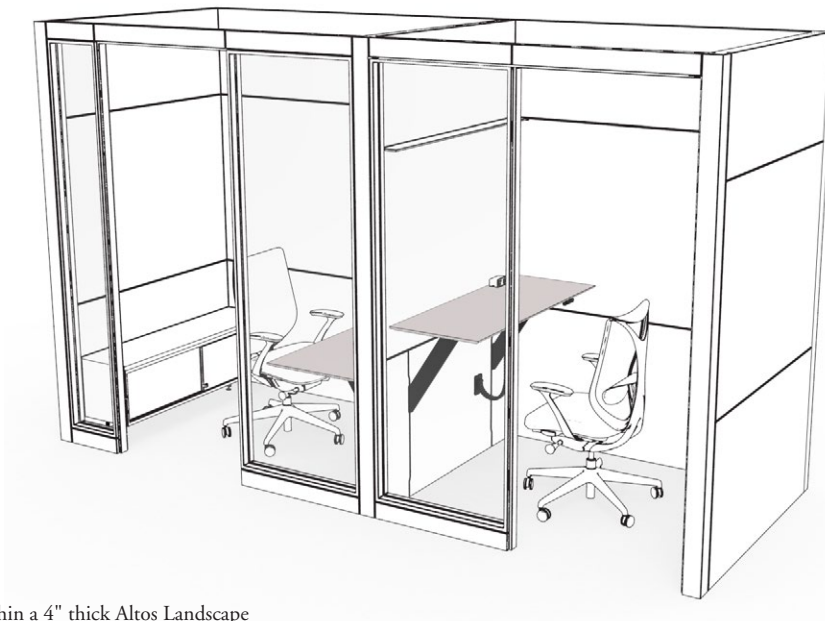

- Available fixed or height-adjustable
- Available single or double sided within a 4" thick Altos Landscape wall
- Depths available:
 - 24" (nominal)
 - 30" (nominal)
- Widths available include 60" - 84" (nominal) in 6" increments
- Available with desk-mounted Power / USB / Data options
- Worksurface Edges include:
 - Flat
 - Knife
 - Eased

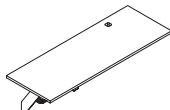
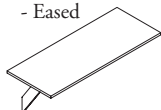

Landscape Desk Fixed (FLDFX)

- Heights available include:
 - 29"
 - 42"
- Leveling capability independent from the wall
- The back of the cantilever allows for electrical routing into the wall

Landscape Desk Height-Adjustable (FLDHA)

- Height-adjustable leveling range is 28" - 44"
- E-chain allows for electrical routing into the wall

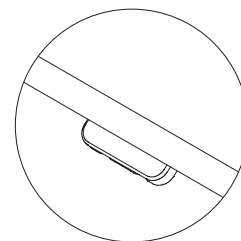

Landscape Desk Switch

- Intuitive form and function (lift up to move desk up, push down to move desk down)
- Memory positions
- Support/instructional content available on the Linak website: www.linak.com

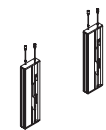

Landscape In-Wall Connection for Height-Adjustable Desk (FLDHAC)

- Provides connection needed from Landscape Height-Adjustable Desk (FLDHA) to Landscape Desk Frame (FLDF)
- Available for single or double sided applications



Landscape In-Wall Connection for Fixed Desk (FLDFXC)

- Provides connection needed from Landscape Fixed Desk (FLDFX) to Landscape Desk Frame (FLDF)
- Available for single or double sided applications

planning with desks – landscape

The following should be considered when planning with Landscape desks.

Desks must be installed so worksurfaces are at the same height relative to each other.

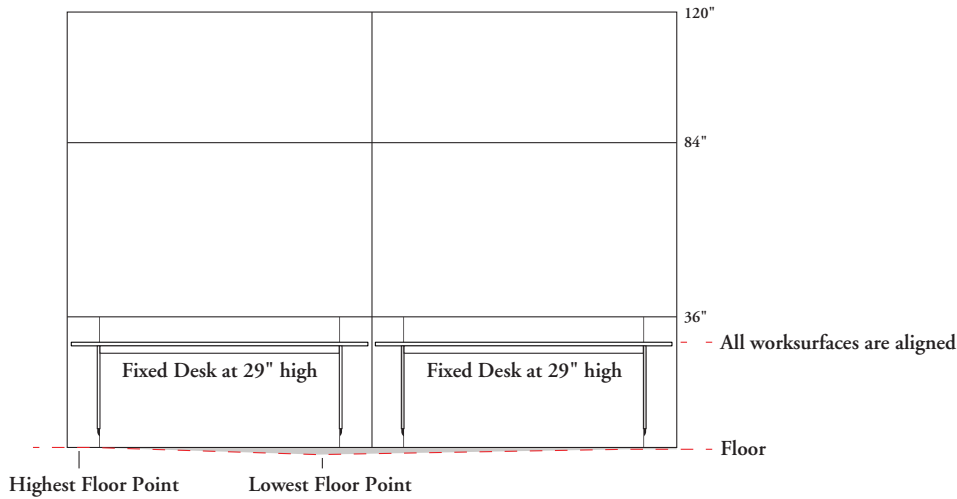

Desks do not follow the floor as worksurfaces will not align.

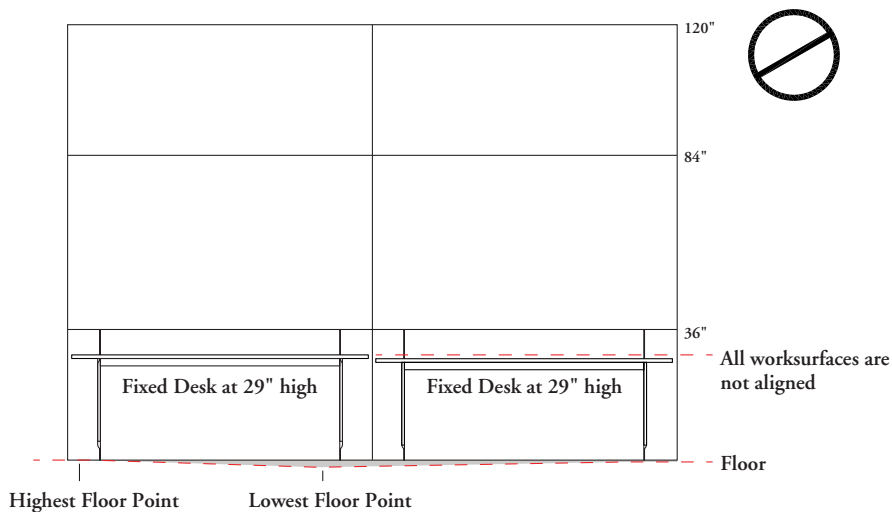

planning with desks – landscape (continued)

The Landscape Desk (fixed or height-adjustable) can be planned centered on the wall or justified to the left or the right of the wall.

- Upper fascias are above the 36" datum while under desk fascias are below 36"
- Upper and under desk fascias must correspond to the desk location, centered or justified
- When a desk is centered on the wall module use standard Landscape fascias above the desk, except the ceiling & base fascia which must be justified.

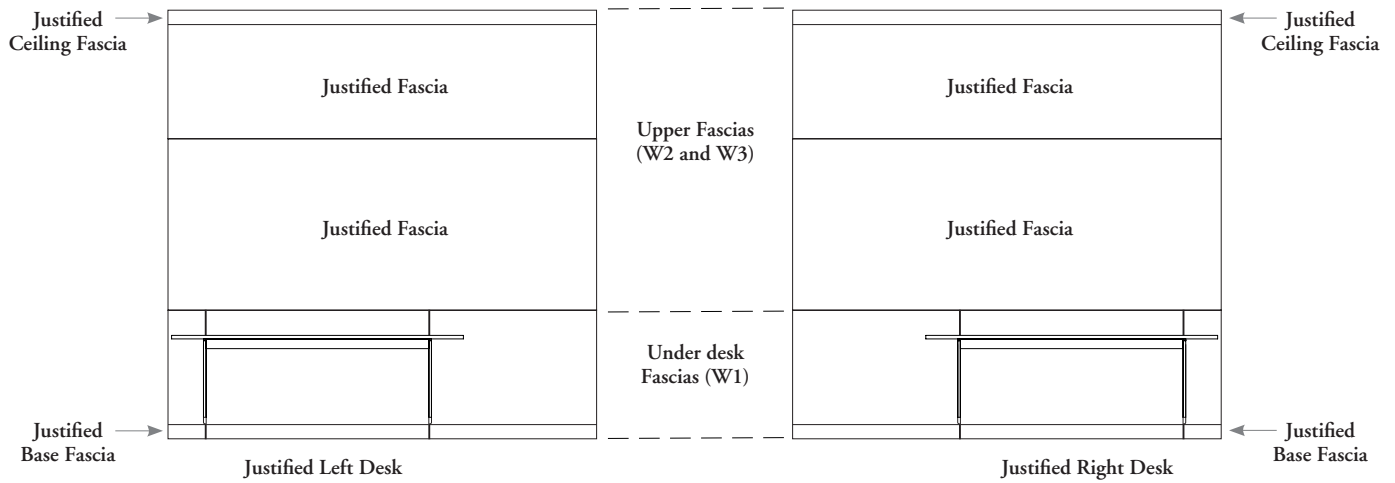

When a desk is centered on the wall module use standard Landscape fascias above the desk, except the ceiling & base fascia which must be justified.

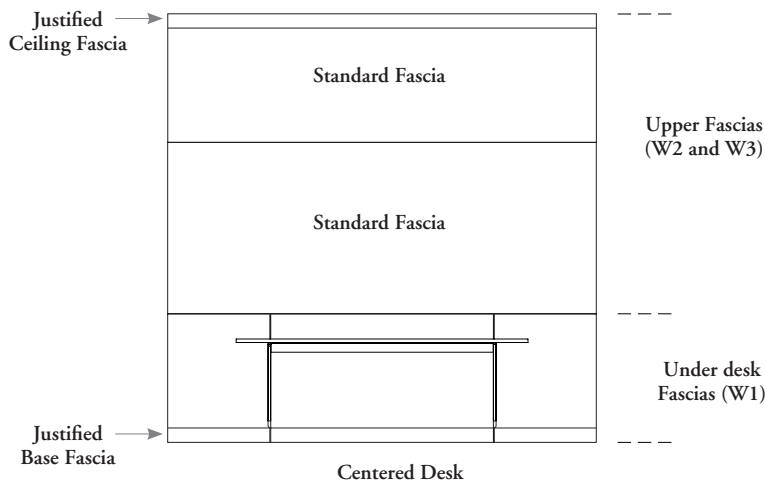

planning with desks – landscape (continued)

- Desk can be planned below a Framed and Frameless Glass Whiteboard fascia. However, they **cannot** be specified below a Glass Fascia, including a Landscape Clerestory
- Landscape Desks **cannot** have a greater width than the width of the wall module it is mounted on

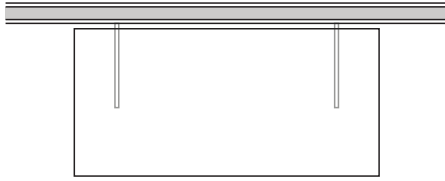

Single Sided - Centered

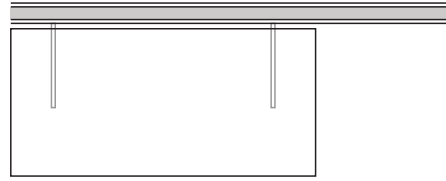

Single Sided - Justified (left shown)

Altos Desks sharing a wall module back to back must be the same width, the same type (fixed or height-adjustable), and in alignment as they share the same supporting frame and wall connection.

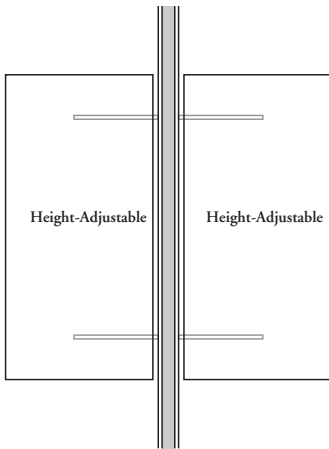

Correct Application

- Same width
- Same type
- In alignment

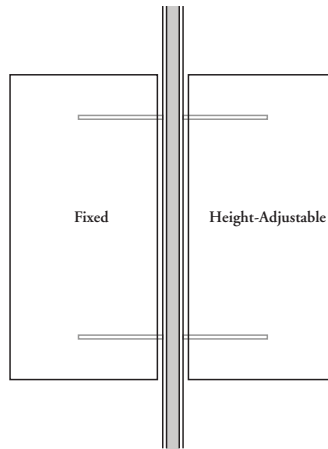

Different types (fixed/height-adjustable)

- Must be both Height-Adjustable or both Fixed

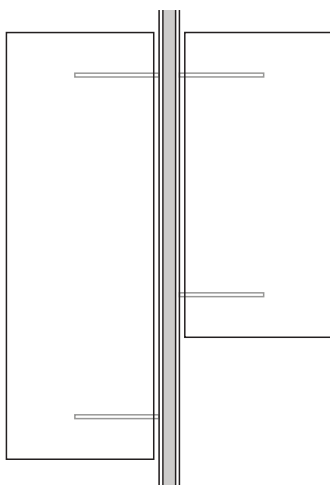
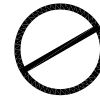

Different widths

- Must be the same width

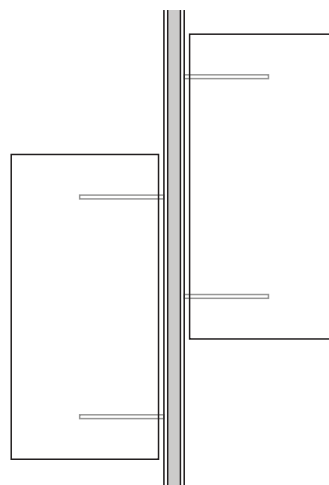

Not aligned

- Must be in alignment with each other on the wall

planning with desks – landscape (continued)

Landscape Desks have an actual width that is less than the nominal width to allow for a 1-1/8" gap around both sides and back of the desk.

Example:

30" x 60" Nominal = 28-7/8" x 57-3/4" Actual

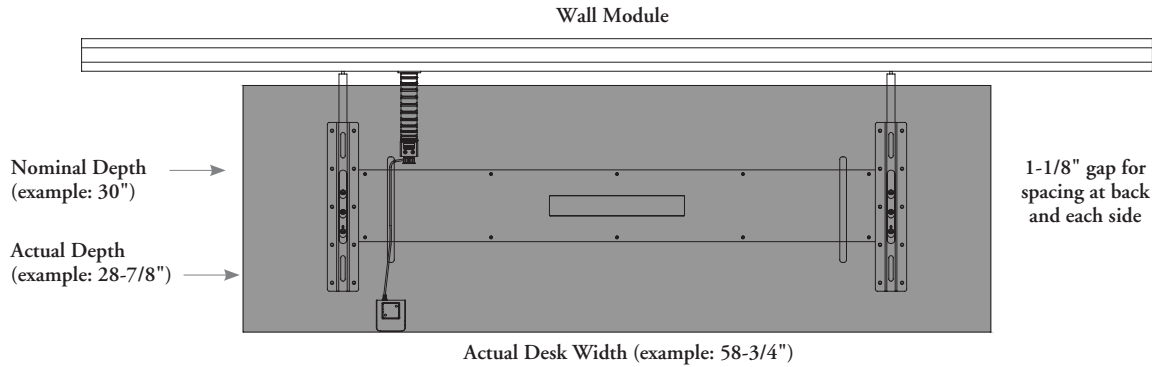

If the Desk is height-adjustable, a minimum of 1" gap is required between the end of shelf at 36" datum and the Desks worksurface edge

- Full overlap is permitted if the desk is a fixed
- Full overlap is permitted for shelves / lights mounted at 60" or 84" datums

Lights and shelving must be specified at the 60" or 84" datum. They must also be the same nominal width and be specified centered over the desk.

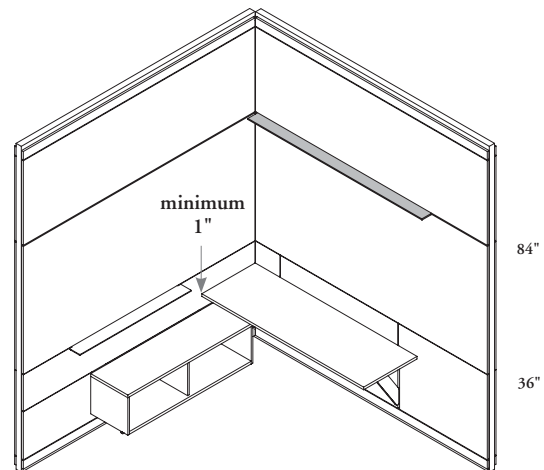
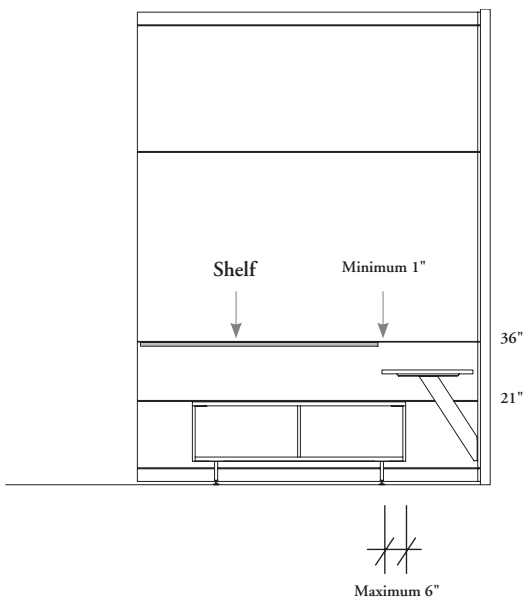

* When a Landscape Desk has been specified on a wall run, storage cabinets cannot be mounted on the same wall module as horizontal rails are in different locations.

planning with desks – landscape (continued)

Cabinets overlapping below the Landscape Desk can be no more than 18" from edge of fascia. It is not recommended to keep anything in the overlap zone below a height-adjustable desk.

Overlapping with a 24" deep desk

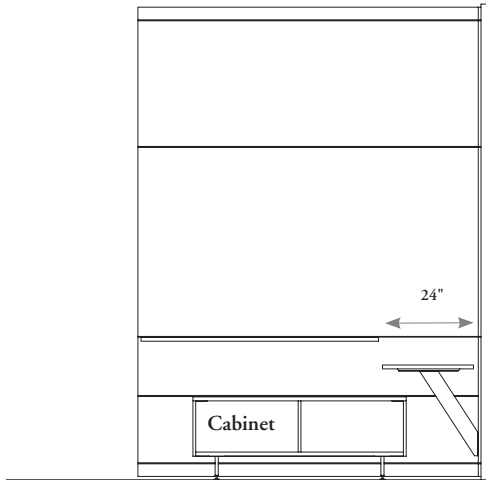

6" overlap zone

Overlapping with a 30" deep desk

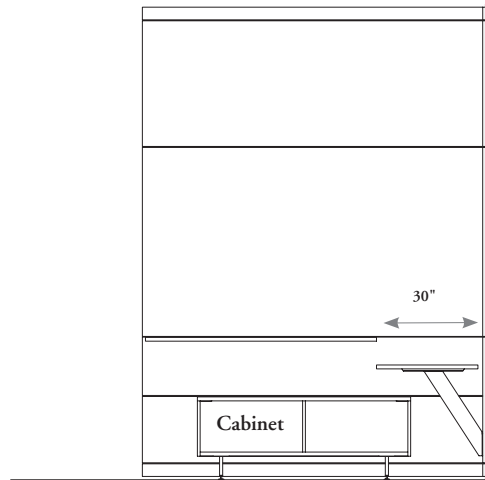

12" overlap zone

planning with desks – landscape (continued)

When planning two worksurfaces in the corner of a room it is recommended that the one corner desk be specified up to the corner and the adjacent desk be specified 1" from the front edge of the corner desk.

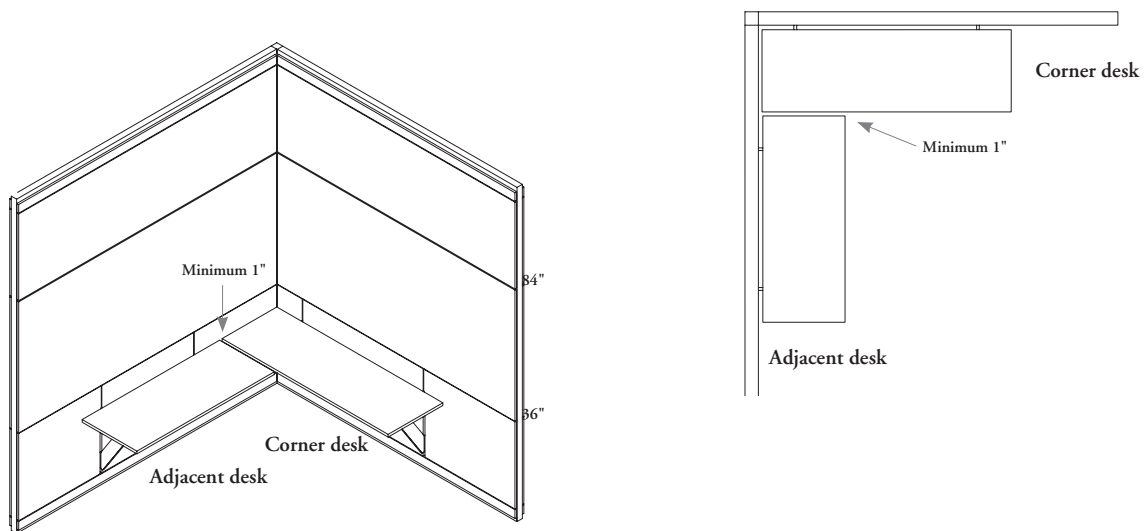

The adjacent desk can be specified centered, justified left or justified right on the wall.

Centered on wall module

Justified left on wall module

Justified right on wall module

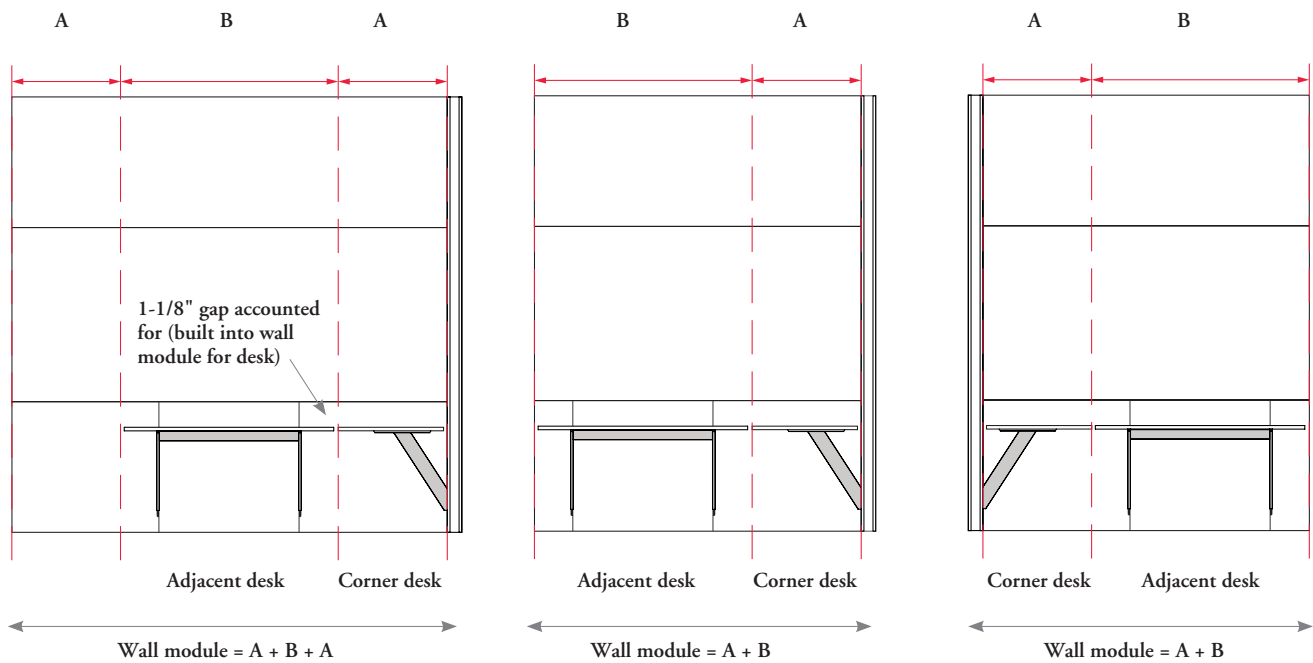

A = Nominal depth of desk (24" or 30")

B = Nominal width of desk (60", 66", 72", 78", or 84")

Wall module width depends on the type of fascia used
(maximum width = 120")

planning with desks – landscape (continued)

When planning with three desks in a room, adjacent desks are best planned centered on the wall between two corner desks.

Centered on wall module

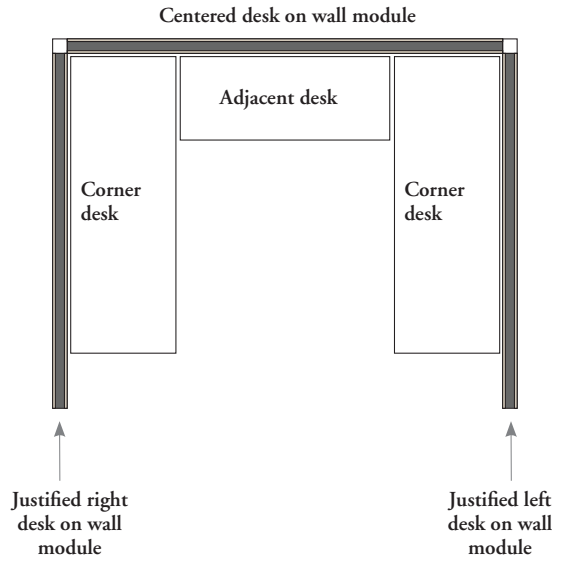
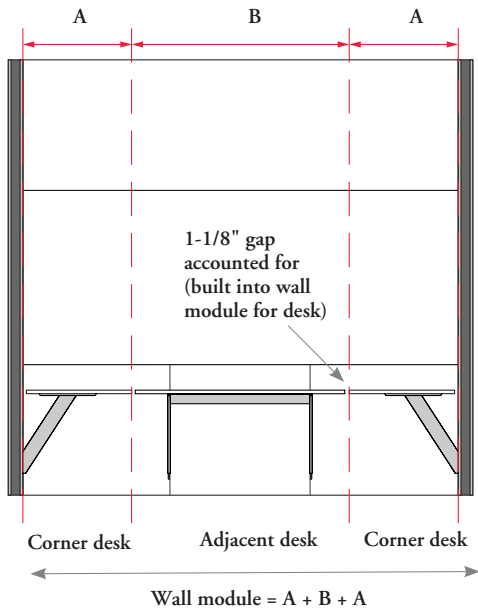

A = Nominal depth of desk (24" or 30")

B = Nominal width of desk (60", 66", 72", 78", or 84")

Wall module width depends on the type of fascia used (maximum width = 120")

When planning corner desks as below creates undesirable layouts. This also increases planning complexity and is not a recommended planning application.

Justified desk wall module

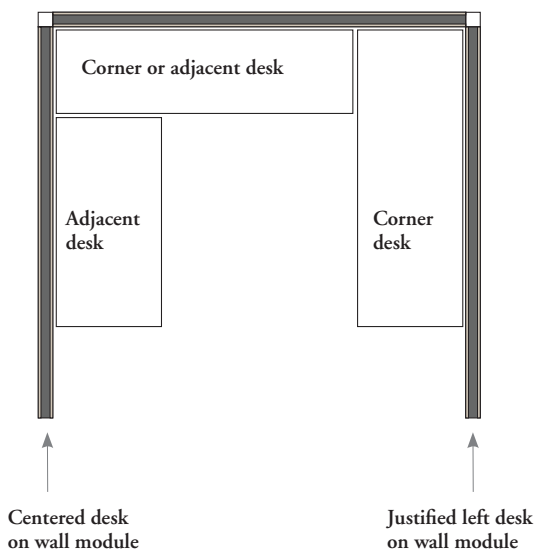

planning with desks – landscape (continued)

single application

Desks should have a minimum of 42" of space between the front of the desk and back wall or any wall-mounted component.

Example:

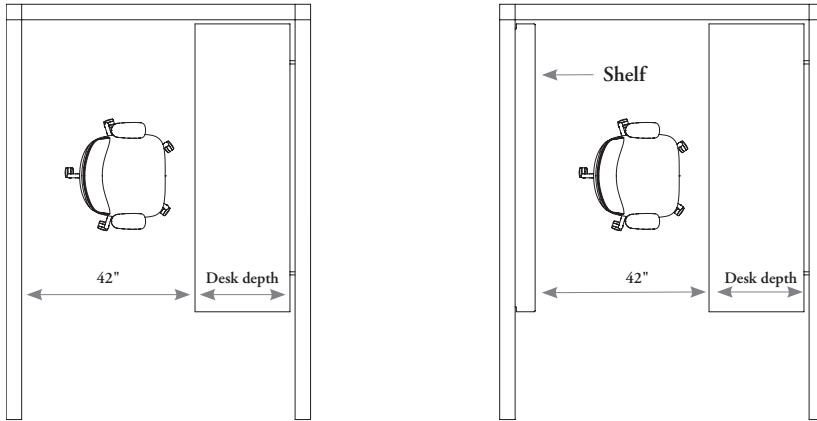

back-to-back application

Desks should have a minimum of 42" of space between the front of the desk and the center of the room to allow for adequate spacing.

Example:

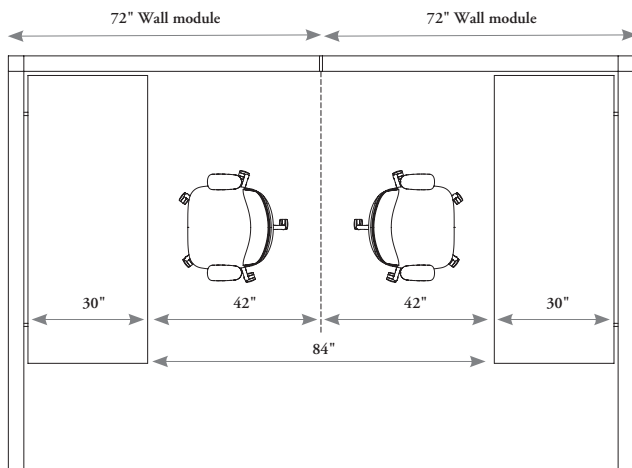

planning with desks – landscape (continued)

When planning two adjacent desks on a wall run, fascias must be split between the desks.

- Adjacent desks can be centered or justified on their individual fascia modules
- Adjacent desks and wall modules do not have to be the same width increment

Example:

Two 60" Center Desk Modules

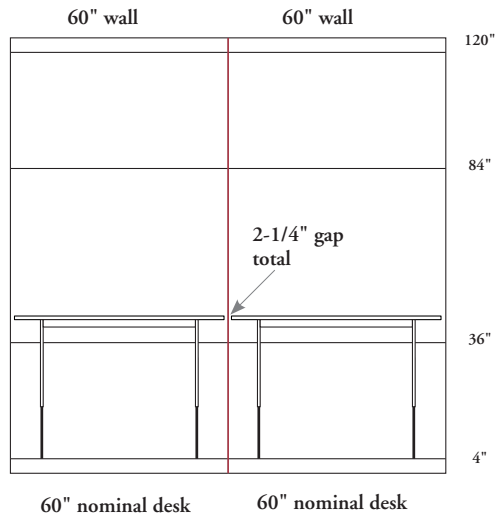

desk accessory overview – landscape

The following electrical accessories are available on Landscape desks to provide desktop power and cable routing capabilities. For more details please see Lighting, Electrics & Communications section.

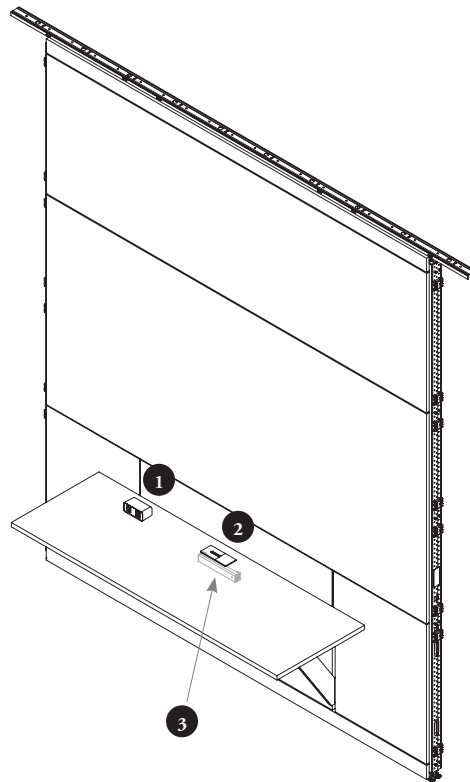

On-desk Accessories are available in Lighting, Electrics & Communications section:

- 1 Power Cube (EPWR):**
 - Dual or Quad power cube available with power, USB or data options
 - Available on left or right side of desk
 - Power Cube and e-chain comes on the same specified location as the switch
 - Appropriate cut out locations must be specified on Desk to accommodate On-desk Accessories
- 2 Rectangular grommet (FLGR):**
 - For cables routing to under-desk Power Rod (ELPR)
 - Cut out accommodates Expansion grommet for Mast Monitor Arm
 - Available centered on worksurface if center grommet cut out is specified
- 3 Power Rod (ELPR)**
 - For powering permanent devices under the desk (example: Monitors, Docking Stations)
 - Available centered below desk

desk finishes – landscape

The following finishes are available on Landscape fixed and height-adjustable desks.

Material and finish options:

- 1 Worksurface available in:
 - Laminate
 - Seamless
 - Flintwood
- 2 Power Cube (EPWRC) available painted:
 - Foundation
 - Accent
 - Mica
- 3 Underside finish is Painted (Foundation, Mica) or Clear Anodized
 - Underside components consist of Cantilever legs and Cross Beam
 - If Clear Anodized underside is specified, Cross Beam will be painted Platinum to coordinate with the anodized Cantilever leg
- 4 Wire Management: Black or Grey depending on underside finish selection:
 - Wire Management for height-adjustable desks is an E-chain and Wall Port (not shown)
 - Wire Management for Fixed Desks is mounted on the back of the Cantilever leg. (shown)
 - Black Wire Management if underside is specified as:
 - Granite
 - Ebony
 - Anthracite
 - Burnished Bronze
 - Slate
 - Gilded Ash
 - Sepia Bronze
 - Graphite
 - Earth
 - Titanium Grey
 - Grey Wire Management if underside is specified as:
 - Crisp Grey
 - Soft Gris
 - Sand
 - Platinum
 - Very White
 - Clear Anodized
- 5 Rectangular Grommet (FLGR) available in plastic finishes:
 - Clear Anodized Coordinate
 - Soft Gris
 - Platinum
 - Anthracite
 - Very White

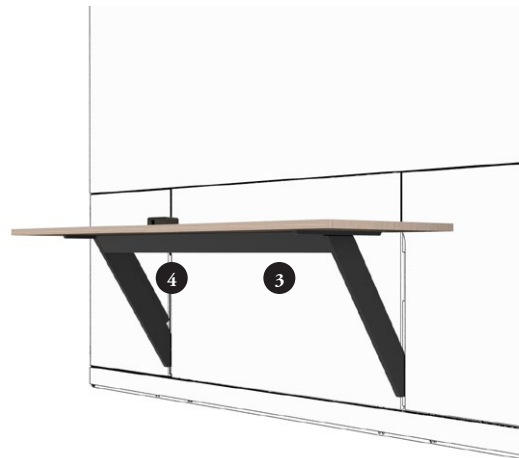
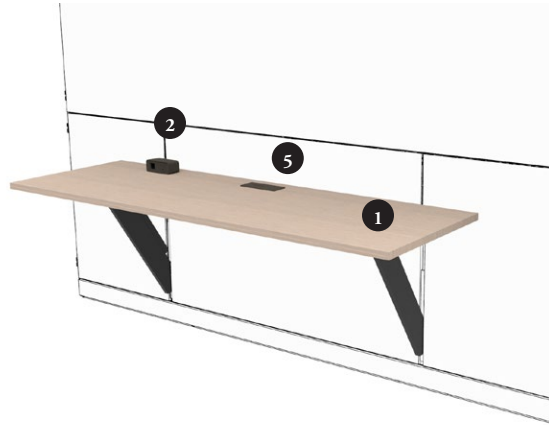

wall-mounted cabinet basics – landscape

Landscape elevated cabinets provide a wall-mounted storage solution for temporary or personal storage. Elevated cabinets can be mounted to the 21" high functional rail only.

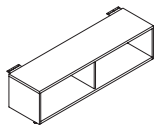
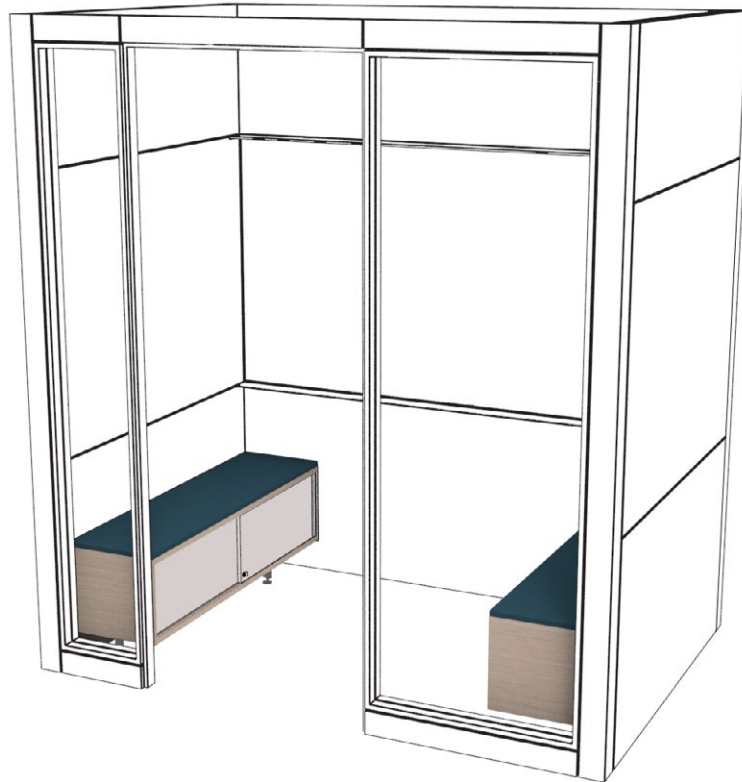

Landscape Wall-Mounted Sliding Door Cabinet (FLWCS) / Open Cabinet (FLWCO)

- Available 16" deep x 15" high
- Can be mounted in front of solid fascias only
- 30" - 60" wide in 6" increments
- Finishes:
 - Case: Seamless, Flintwood, Source Laminate
 - Fronts: Seamless, Flintwood, Source Laminate, Glass (Backpainted or Frosted)
 - Wall Mounting brackets: Painted (Foundation, Mica)
 - Legs painted Ebony



Fitted Seat Cushion (FLFC)

- Can be used on Landscape Cabinets as temporary guest seating
- 16" deep and 24" - 60" wide in 6" increments
- Available in Upholstery or COM Fabrics
- Fabric Directionality is railroad

planning elevated cabinets – landscape

The following should be considered when planning with Landscape Elevated Cabinets.

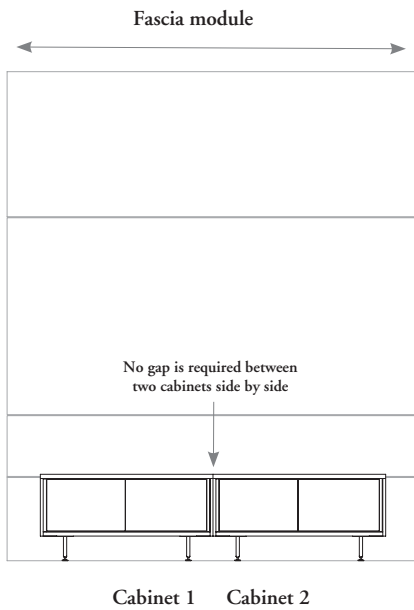

Multiple Cabinets can be planned on a single datum within one Fascia Module.
Two cabinets side by side can be installed with no gap between them.

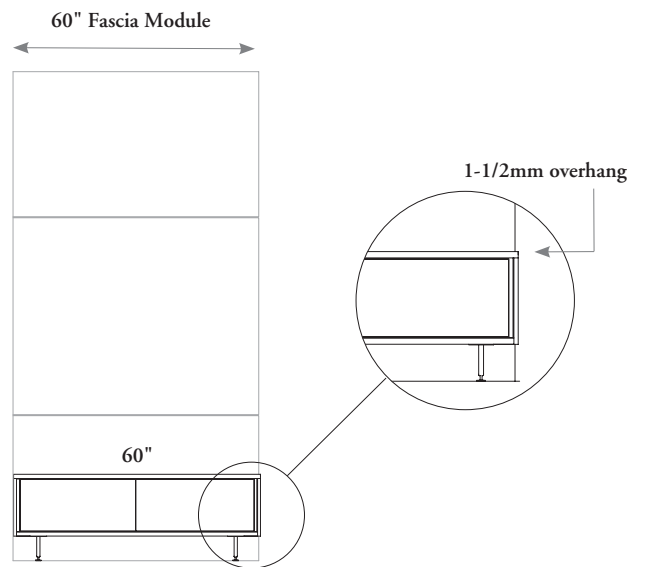

When planning with a cabinet that is the same nominal width as the wall module, the cabinet will overhang the fascia edge by 1-1/2mm

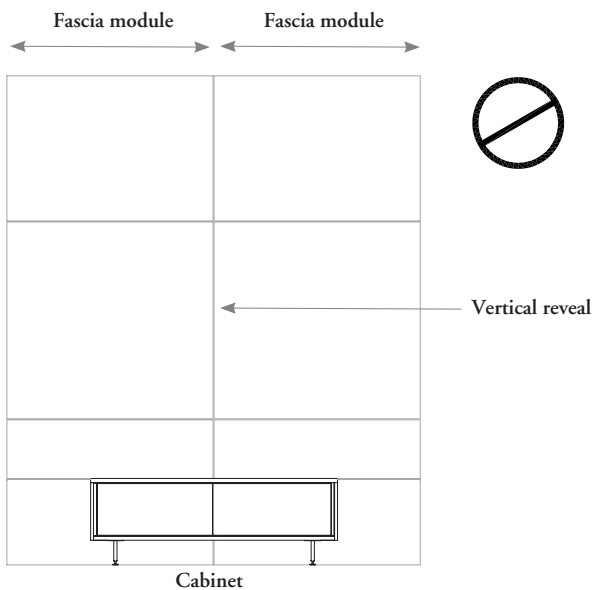

Landscape Elevated Cabinets cannot span across a vertical reveal.

planning elevated cabinets – landscape (continued)

Landscape Cabinets can be installed along the Functional Rail in 1/8" increments on the horizontal reveal.

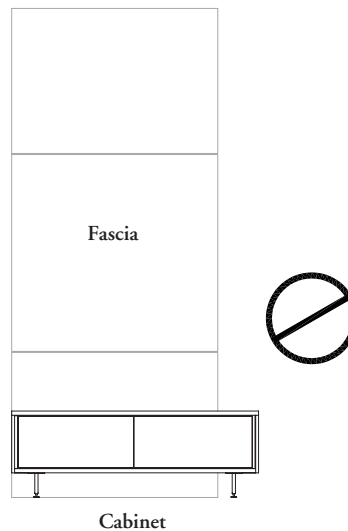
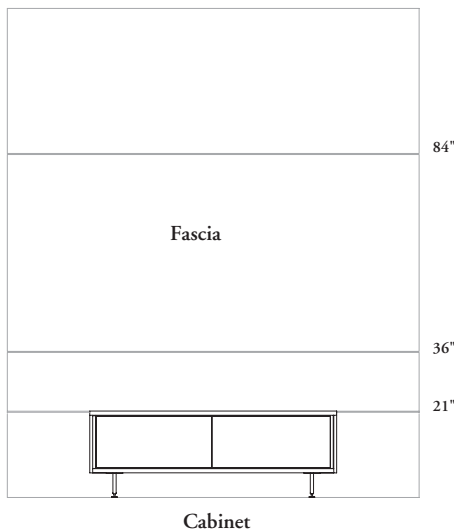

- Cabinets will align to the edge of the fascia when fully justified left or right on the wall
- Cabinets are only used along the 21" datum
- The Cabinet Working Wall fascia arrangement must be used when using a Landscape cabinet

- Cabinet nominal width must be equal to or less than nominal width of the fascia.

Planning with a Sliding Door Cabinet in a corner application is not recommended due to difficulties accessing the Corner Cabinet door handle. A minimum gap of 1" is recommended between the side of the Adjacent Cabinet and the Corner Cabinet.

